



Turbochargers | Intercoolers | Valves | Accessories

PERFORMANCE CATALOGUE VOL 9

TABLE OF CONTENTS

- 04** WHY CHOOSE GARRETT
 - 07** HOW TO READ A COMPRESSOR MAP
 - 12** G-SERIES II
 - 20** G-SERIES
 - 46** G-XRACE
 - 54** GTX GEN II
 - 74** GARRETT BOOST | CLUB LINE
 - 82** GTW SERIES
 - 88** GT SERIES
 - 100** CLASSIC SERIES
 - 104** GARRETT VENT | WASTEGATES
 - 108** GARRETT VENT | BLOW-OFF VALVES
 - 110** ACCESSORIES | SPEED SENSORS | BOOST GAUGES | ACTUATORS
 - 112** G-SMART BLUETOOTH MODULE
 - 114** POWERMAX | VEHICLE SPECIFIC TURBOCHARGERS & INTERCOOLERS
 - 139** PERFORMANCE INTERCOOLER CORES
 - 141** ANCILLARY COMPONENTS
 - 142** TURBINE FLANGE DIAGRAMS
 - 144** TROUBLESHOOTING GUIDE
-

OUR HISTORY

The heritage of our turbo business began in 1936 when young Cliff Garrett formed his company in a tiny, one-room office in Los Angeles. Cliff founded the company that would later become the Garrett Corporation. Number of employees, 1. Number of customers, 1. In the 1950s, it successfully added boosting a Caterpillar C9 tractor signaling the birth of automotive turbocharging.

With over sixty-five years of boosted experience, Garrett technology has been utilized by nearly every major global auto maker, resulting in approximately 100 million vehicles with our products and an average launch rate of 100 new applications annually spanning from gas, to diesel, fuel cell, and racing and performance applications.

From the world's first turbocharged production car - the Oldsmobile Jetfire Rocket - to the first Garrett turbocharged car to win the Indianapolis 500, Garrett's industry-leading technology and patented designs are used daily for both OE and aftermarket vehicle applications.

Today, our Garrett legacy in the automotive industry helps create some of the most innovative and high-performing turbochargers in the world that can enable a four cylinder turbocharged engine to perform like a non-turbocharged V6 engine while providing 20-40% greater fuel efficiency. Garrett's global engineering network continues to inspire technological innovation around the world.

The products contained in this catalog are performance aftermarket parts that are not legal for street use in certain states or countries, unless a type-approval/executive order has been obtained e.g. by the distributor of the product. Check with your distributor before using in any vehicle on a public road or highway. You should check with your state or applicable country authorities to find out whether these products are legal for street use in your state or country. Applicable laws may also prohibit tampering with parts or vehicle design elements affecting emissions on vehicles intended for use on public roads. You are responsible for ensuring that the use of this product complies with all applicable laws, regulations and ordinances (including, but not limited to, emission, noise, safety, and type-approval/executive order). Any vehicle modifications using the products in this catalog are completed AT YOUR OWN RESPONSIBILITY and AT YOUR OWN RISK. A vehicle modification using these performance aftermarket products may affect or void a vehicle's warranty, operating license/registration or type-approval/executive order. You should consult your local laws, as well as the owner's manual and service manual of your vehicle. You should also contact your vehicle's manufacturer to determine what effect modifications may have on safety, warranty, performance, and other aspects of your vehicle. These products generally may be used on racing vehicles that will never be driven on public roads or highways.

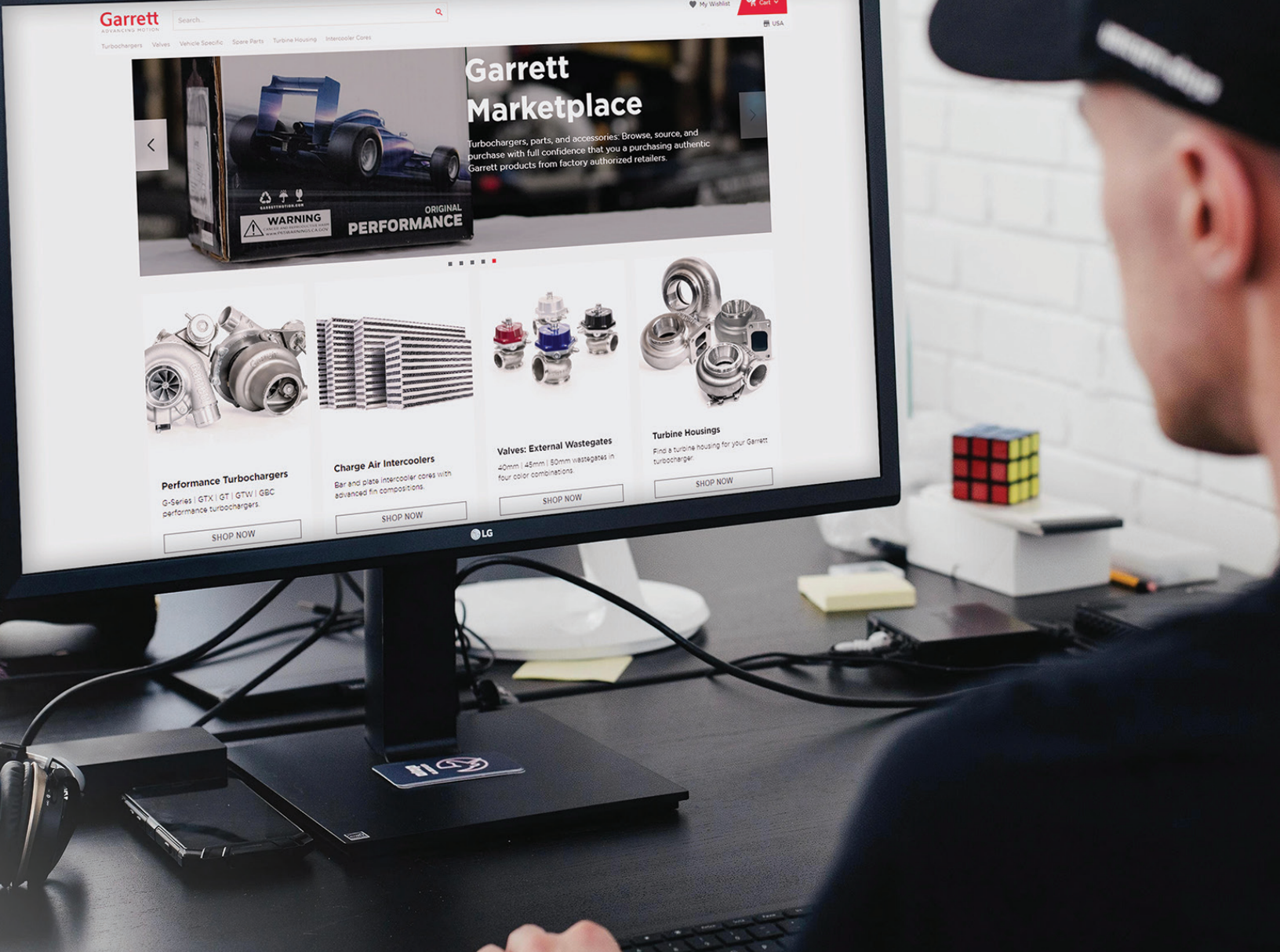

SHOP.GARRETTMOTION.COM

GARRETT **MARKETPLACE**

Browse, Source, Purchase
Genuine Garrett Products
From Authorized Distributors



SHOP NOW

it
one

GTX35 GTX35 Gen II
Turbine Housing Standard
Rotation 1.06A/R T3 Inlet V-Band
Outlet

IN STOCK

[View more](#)

GTX35 Supercore Standard Rotation 66MM Comp Ind

Reference: 851154-50045



Starting at: \$1,074.75
* Excluding taxes

IN STOCK

Create your own kit
Turbine Housing: None

**GT35 GTX35 Gen II
Turbine Housing Standard
Rotation 1.06A/R T3 Inlet V-Band
Outlet**

IN STOCK

[View more](#)

Mail

Garrett
ADVANCING MOTION



Garrett
ADVANCING MOTION

Garrett
ADVANCING MOTION

PERFORMANCE

Garrett Marketplace

Turbochargers, parts, and accessories: Browse, source, and purchase with full confidence that you a purchasing authentic Garrett products from factory authorized retailers.



Mail

Garrett
ADVANCING MOTION

Garrett Vent | External Wastegate GVW50
50mm

VIEW MORE

Garrett Vent | External Wastegate GVW45
45mm

VIEW MORE

Garrett Vent | External Wastegate GVW40
40mm

VIEW MORE

Mail

Garrett
ADVANCING MOTION

Charge Air
Bar and plate
advanced fin

Top



Garrett
ADVANCING MOTION

WHY CHOOSE GARRETT TURBOCHARGERS

A turbo is a high technology product that requires superior design and intensive capital to produce. It must meet severe requirements that only a world class manufacturer can achieve.

Garrett is one of the few turbocharger manufacturers that subjects our turbos to several OE qualification tests. These tests ensure Garrett produces a safe and reliable turbo for OE applications. When you buy a Garrett turbocharger you can be sure it is reliable.

On-Engine Durability - More than 1,000-hours of general turbocharger durability, is run on-engine in one of Garrett's engineering laboratories.

Gas Stand Cyclic Durability - A several hundred hour durability test is conducted on a gas stand where the turbo is run past its normal operating limits.

Compressor & Turbine Housing Containment - A compressor/turbine wheel is weakened to hub burst at a specific speed. No portion of the wheel is allowed to penetrate a containment shroud surrounding the turbocharger. A test to ensure safety. See full article at www.GarrettMotion.com

Shaft Motion - The maximum tolerances of the bearing system are tested for rotordynamic stability beyond the maximum turbocharger operating speed. This means no bearing problems and a long turbo life.

Thrust Bearing Capacity - A test that stresses the thrust bearing at extreme conditions. This test makes sure your Garrett turbocharger can tolerate the load you put it through.

Compressor & Turbine Seal - Multiple turbochargers are run on-engine under conditions designed to cause seal leakage. No significant leakage is allowed during these tests.

Heat Soak Back - A turbocharger instrumented with thermocouples is taken beyond maximum operating temperature and shut down hard! Repeat the test four more times and make sure maximum temperatures stay within our strict limits to avoid oil coking or build up inside the center housing. This is particularly critical for high temperature gasoline applications.

Compressor & Turbine Performance - The entire operating range of both the compressor and turbine are mapped on one of Garrett's performance gas stands. These test cells are calibrated to strict standards to assure accuracy and consistency.

Compressor & Turbine Blade Frequencies - Garrett has strict requirements for compressor and turbine blade natural frequency. This is critical on large trims where the blade must be stiff enough to withstand potentially damaging vibrations.

Thermal Cycle - A several hundred hour endurance test that cycles the turbocharger from low temperature to glowing red every 10 minutes. To ensure a long turbo life, no cracking of the turbine housing or distortion of the heat shroud are allowed.

Rotor Inertia - A measurement made to document the rotational inertia of Garrett's compressor and turbine wheels. Garrett's turbochargers are known for their high flow / low inertia characteristics.

Shaft Critical Speed - An analytical test that ensures that destructive shaft critical speeds are well out of the turbocharger operating range. For example, large wheels may require a large shaft diameter to avoid the shaft bending critical speed.

Wheel Fatigue - Garrett will only sell compressor or turbine wheels that have passed a cyclic fatigue test. Garrett runs tests on a regular basis to ensure quality and to constantly improve our products.

Turbo Vibration - The entire turbocharger is vibrated and monitored on Garrett's large shaker table to ensure product durability.

Engine power is proportional to the amount of air and fuel that can get into the cylinders. All things being equal, larger engines flow more air and as such will produce more power. If we want our small engine to perform like a large engine, or simply make our larger engine produce more power, our ultimate objective is to deliver more air into the cylinder. By installing a Garrett turbocharger, the power and performance of an engine can be dramatically increased.

HOW DOES A TURBOCHARGER DELIVER MORE AIR INTO THE ENGINE?

- (1) **Compressor Inlet:** Opening through which ambient air passes before entering the compressor.
- (2) **Compressor Discharge:** Ambient air is then compressed which raises the air’s density (mass/unit volume).
- (3) **Charge Air Cooler (aka Intercooler):** cools the compressed air to increase its density and to increase resistance to detonation.
- (4) **Intake Manifold:** Directs dense air into the engine’s cylinders. Each cylinder draws in an increased mass flow rate of air. Higher air mass flow rate allows a higher fuel flow rate (with similar air/fuel ratio). Combusting more fuel results in more power for a given displacement.
- (5) **Exhaust Manifold:** Directs burned fuel and exhaust gases from the cylinders towards the turbine.
- (6) **Turbine Inlet:** Directs high temperature exhaust gas towards the turbine wheel. The turbine creates back pressure on the engine which means engine exhaust pressure is higher than atmospheric pressure.
- (7) **Turbine Discharge:** A pressure and temperature drop occurs (expansion) across the turbine, which harnesses the exhaust gas’ energy to provide the power necessary to drive the compressor wheel.

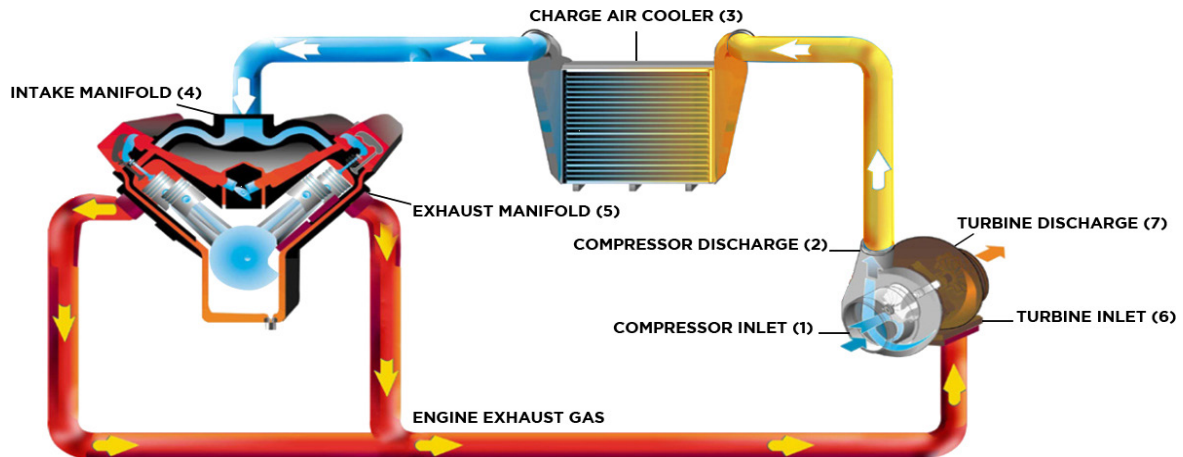

COMPONENTS OF A TURBOCHARGER

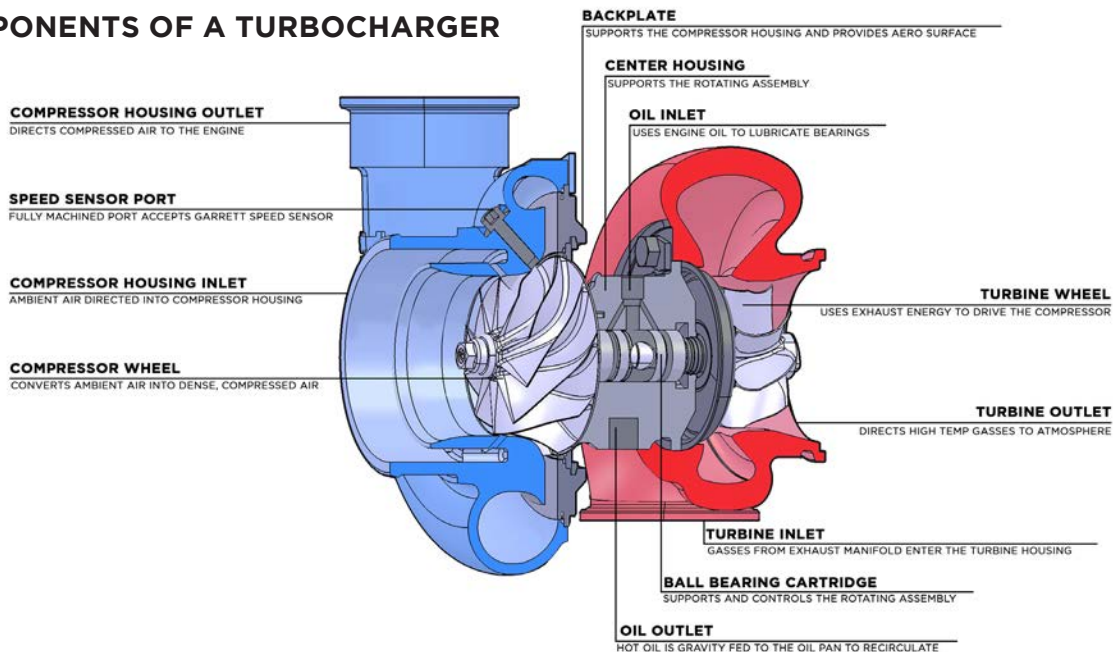

BALL BEARING TECHNOLOGY

Ball bearing innovation began as a result of work with the Garrett Motorsports group for several racing series where it received the term the “cartridge ball bearing”. The cartridge is a single sleeve system that contains a set of angular contact ball bearings on either end, whereas the traditional bearing system contains a set of journal bearings and a thrust bearing.

Turbo Response - When driving a vehicle with the cartridge ball bearing turbocharger, you will find exceptionally crisp and strong throttle response. Garrett Ball Bearing turbochargers spool up 15% faster than traditional journal bearings. This produces an improved response that can be converted to quicker 0-60 mph speed. In fact, some professional drivers of Garrett ball-bearing turbocharged engines report they feel like they are driving a large, normally aspirated engine.

Reduced Oil Flow - The ball bearing design reduces the required amount of oil required to provide adequate lubrication. This lower oil volume reduces the chance for seal leakage. Also, the ball bearing is more tolerant of marginal lube conditions, and diminishes the possibility of turbocharger failure on cold start conditions. Read more at www.GarrettMotion.com

Improved Rotordynamics and Durability - The ball bearing cartridge gives better damping and control over shaft motion, increasing reliability for both every day and extreme driving conditions. In addition, the opposed angular contact bearing cartridge eliminates the need for the thrust bearing, a common weak link in the turbo bearing system.

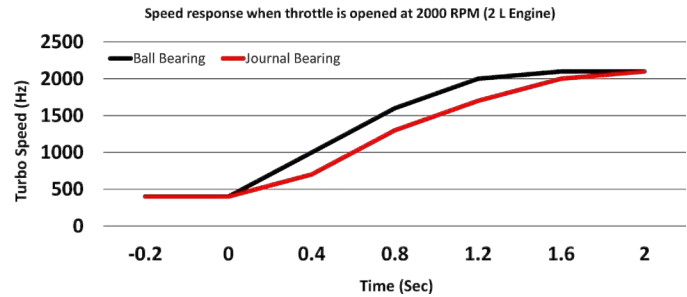

WHEEL TRIM

Trim is a common term used when talking about or describing turbochargers. For example, you may hear someone say "I have a GTXxxxx". What is trim? Trim is a term used to express the relationship between the inducer and exducer of both turbine and compressor wheels. More accurately, it is an area ratio. Based on aerodynamics and air entry paths, the inducer for a compressor wheel is the smaller diameter. For turbine wheels, the inducer is the larger diameter.

The trim of a wheel, whether compressor or turbine, affects performance by shifting the airflow capacity. All other factors held constant, a higher trim wheel will flow more than a smaller trim wheel. However, it is important to note that very often all other factors are not held constant. So just because a wheel is a larger trim does not necessarily mean that it will flow more.

Compressor Trim = (Inducer² / Exducer²) x 100

Turbine Trim = (Exducer² / Inducer²) x 100

WHEEL MEASUREMENTS EXPLAINED

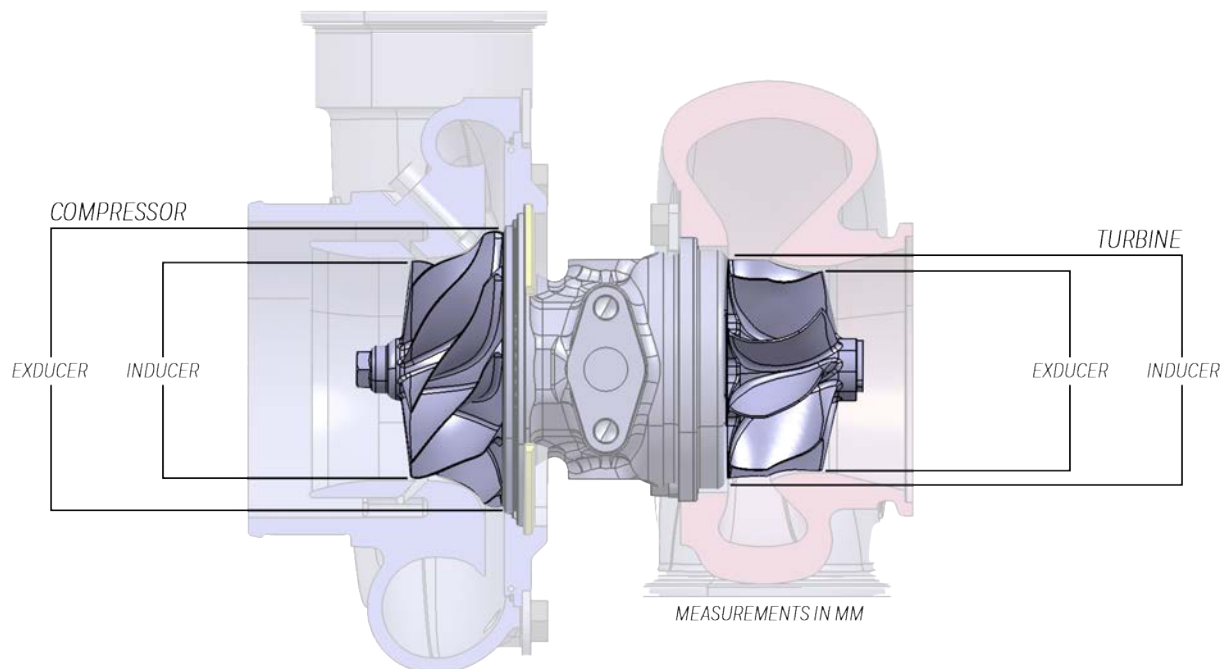

The compressor map describes each compressor's performance characteristics, including efficiency, mass flow rate, turbo speed, choke line, surge line, and pressure ratio. Below is a figure that identifies these aspects.

Efficiency Islands: Efficiency Islands are concentric regions that represent the compressor efficiency at any point on the map. The smallest island near the center of the map is the highest or peak efficiency island. As the rings move out from there, the efficiency drops by the indicated amount until the surge and choke limits are reached.

Mass Flow Rate: Mass Flow Rate is the mass of air flowing through a compressor over period of time and is expressed as lb/min. As a very general rule, turbocharged gasoline engines generate 10.0-11.0* horsepower at the flywheel for each lb/min of airflow. So, an engine with a target peak horsepower of 400 Hp will require 36-40 lb/min of airflow to achieve that target. Many people use Volumetric Flow Rate (expressed in cubic feet per minute, CFM or ft³/min) instead of mass flow rate. Volumetric flow rate can be converted to mass flow by multiplying by the air density. Air density at sea level is 0.076lb/ft³. Mass flow can be physically measured, but in many cases it is sufficient to estimate the mass flow when choosing the proper turbo.

Turbo Speed: Turbo Speed Lines are constant turbo speed measured in RPM. As turbo speed increases, the pressure ratio and mass flow increases. Turbo speed lines are very close together at the far right edge of the map indicating a potential turbo over-speed condition. Maximum turbo speed will be noted with the following symbol. **MAXIMUM TURBO SPEED** ⚠

Choke Line: The Choke Line is the right hand boundary of the compressor map and defined at the point where the efficiency drops below 58%. In addition to the rapid drop of compressor efficiency past this point, turbo speed also approaches or exceeds the recommended limit. If your actual or predicted operation is beyond this limit, a larger compressor is necessary.

Surge Line: Surge is the left hand boundary of the compressor map and represents a region of flow instability. This region is characterized by mild flutter to wildly fluctuating boost from the compressor. Continued operation within this region can lead to premature turbo failure due to heavy thrust loading. Surge will decay once the turbo speed finally slows enough to reduce the boost and move the operating point back into the stable region. This situation is commonly addressed by using a Blow-Off Valve (BOV) or bypass valve. A BOV functions to vent intake pressure to atmosphere so that the mass flow ramps down smoothly, keeping the compressor out of surge. In the case of a recirculating bypass valve, the airflow is recirculated back to the compressor inlet.

Pressure Ratio: $\Pi_c = \frac{P_{2c}}{P_{1c}}$

Where:

Π_c = Pressure Ratio

P_{2c} = Absolute Outlet Pressure

P_{1c} = Absolute Inlet Pressure

Absolute Pressure: It is important to use units of Absolute Pressure for both P_{2c} and P_{1c}. Absolute Pressure at sea level is 14.7 PSia. In units of PSia, the "a" refers to "absolute". This is referred to as standard atmospheric pressure at standard conditions.

Gauge Pressure: Measures the pressure above atmospheric, so a gauge pressure reading at atmospheric conditions will read zero. Boost gauges measure the manifold pressure relative to atmospheric pressure, and thus are measuring Gauge Pressure. In units of PSIG, the "g" refers to "gauge". This is important when determining P_{2c}.

Calculating P_{2c}: For example, a reading of 12 PSIG on a boost gauge means that the air pressure in the manifold is 12 PSI above atmospheric pressure. For standard atmospheric conditions, 12 PSIG + 14.7 PSia = 26.7 PSI absolute compressor outlet pressure (P_{2c}). The pressure ratio at this condition can now be calculated: 26.7 / 14.7 = 1.82

Depression: A pressure loss upstream of the compressor caused by any restriction from the air filter or restrictive ducting. Depression can be 1 PSIG or more on some intake systems. In determining pressure ratio, the absolute pressure at the compressor inlet (P_{1c}) is often LESS than the ambient pressure, especially at high load. Taking into account the 1 PSIG intake depression, the pressure ratio is now: (12 PSIG + 14.7 PSia) / 13.7 PSia = 1.95

Elevation: Higher elevations can have a significant effect on pressure ratio. Turbo speed increases to compensate for increases in altitude. Substitute the actual atmospheric pressure in place of the 14.7 PSI in the equations above to give a more accurate calculation. For example, at Denver's 5000 feet elevation, the atmospheric pressure is typically around 12.4 PSia. In this case, the pressure ratio calculation, taking into account the intake depression, is: (12 PSIG + 12.4 PSia) / (12.4 PSia - 1 PSIG) = 2.14 Compared to the 1.82 pressure ratio calculated originally, this is a big difference.

* Performance results of this product are highly dependent upon your vehicle's modifications and tuning/calibration. Horsepower numbers represented in this catalog are calculated based strictly on choke flow of the compressor map (total turbo capability), which represents the potential flywheel horsepower.

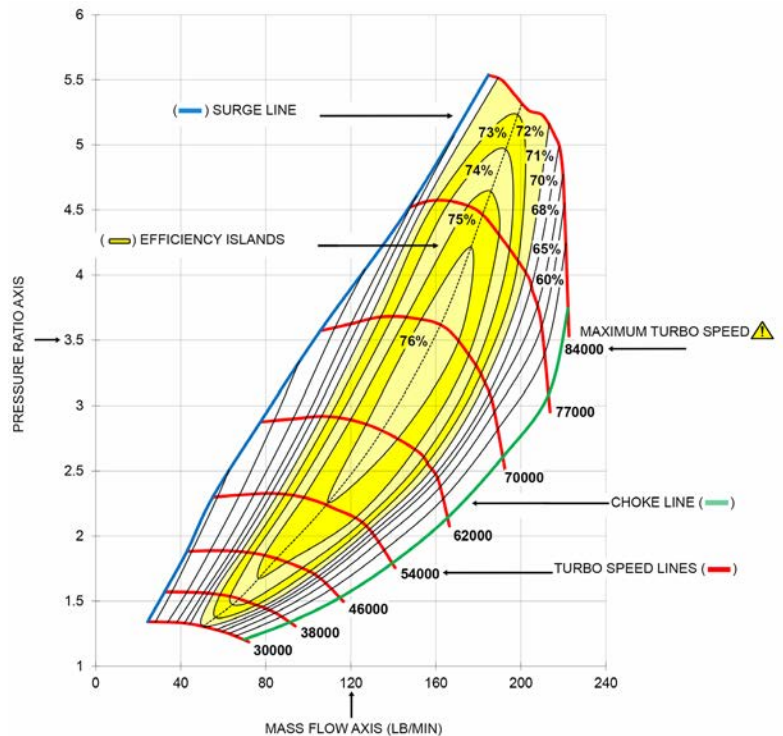

A/R (Area/Radius) describes a geometric characteristic of all compressor and turbine housings. It is defined as the inlet (or, for compressor housings, the discharge) cross-sectional area divided by the radius from the turbo centerline to the centroid of that area.

Compressor A/R - Compressor performance is comparatively insensitive to changes in A/R. Larger A/R housings are sometimes used to optimize performance of low boost applications, and smaller A/R are used for high boost applications. However, as this influence of A/R on compressor performance is minor, there are rarely A/R options available for compressor housings.

Turbine A/R - Turbine performance is greatly affected by changing the A/R of the housing. Using a smaller A/R will increase the exhaust gas velocity into the turbine wheel providing increased turbine power at lower engine speeds and resulting in quicker boost response. The smaller A/R also causes the flow to enter the wheel more tangentially, which reduces the ultimate flow capacity of the turbine wheel. This will increase exhaust back pressure and reduce the engine's ability to breathe effectively at high RPM, adversely affecting peak engine power.

Using a larger A/R will lower exhaust gas velocity, and delay boost response. The flow in a larger A/R housing enters the wheel in a more radial fashion, increasing the wheel's effective flow capacity, resulting in lower back pressure and more power at higher engine speeds.

When deciding between A/R options, be realistic with the intended vehicle use and choose the A/R to bias the performance toward the desired power band characteristic.

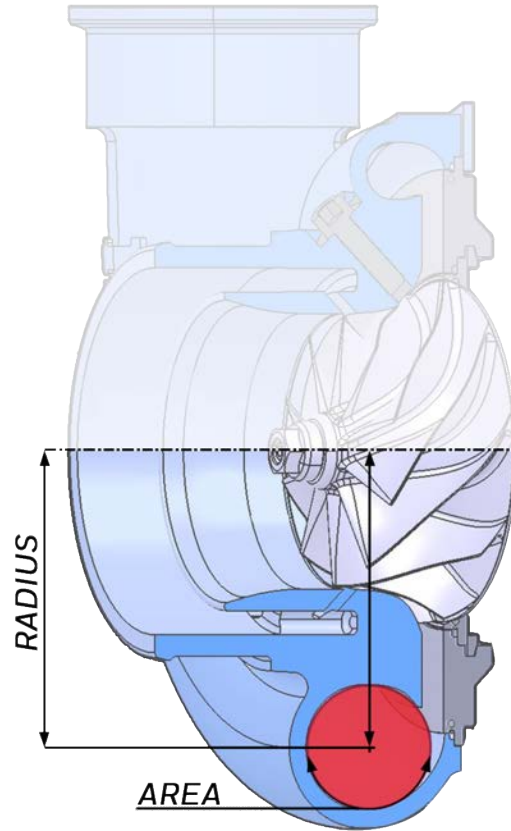

HOW DO I CHOOSE THE RIGHT TURBO

The primary input in determining which turbocharger is appropriate is to have a target horsepower in mind. This should be as realistic as possible for the application. Remember that engine power is generally proportional to air and fuel flow. Once you have a target horsepower identified along with your engine displacement, you begin to hone in on the turbocharger size, which is highly dependent on airflow requirements.

Other important factors include the type of application. An autocross car, for example, requires rapid boost response. A smaller turbocharger or smaller turbine housing would be most suitable for this application. While this will trade off ultimate power due to increased exhaust back pressure at higher engine speeds, boost response of the small turbo will be excellent. Alternatively, on a car dedicated to track days, peak horsepower is a higher priority than low-end torque. Plus, engine speeds tend to be consistently higher. Here, a larger turbocharger or turbine housing will provide reduced back pressure but less-immediate low-end response. This is a welcome trade off given the intended operating conditions.

Selecting the turbocharger for your application goes beyond "how much boost" you want to run. Defining your target power level and the primary use for the application are the first steps in enabling your Performance Distributor to select the right turbocharger for you.

Scan the QR codes below to be directed to the Garrett distributor locator or the Boost Adviser turbo matching tool.



Distributor Locator



Boost Adviser

Turbocharger part numbers are offered in four configurations and it is important to understand the differences when ordering part numbers. This guide will explain the differences. If you have any questions, please contact a Garrett Distributor for more information.

Supercore PN

Supercore refers to a rotating assembly with compressor housing attached. Gasket kit included. Turbine housing not included.

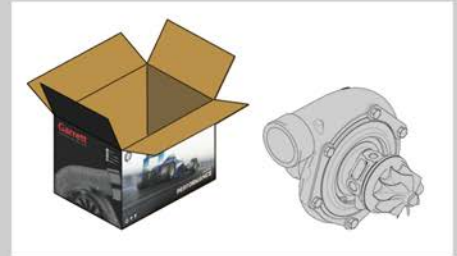

Turbine Kit PN

Individually packaged turbine exhaust housings. Connections and size vary between models. Gasket kit, bolts, clamps, V-band/s included. Weld flanges are not included

- Reverse rotation turbine housings are **not** interchangeable with standard rotation supercores
- GT | GTX | GTX Gen II turbine housings **are** interchangeable within the frame family. (GT30 | GTX30 | GTX30 Gen II)
- G-Series housings are **not** interchangeable with GT | GTX | GTW
- GTW housings are **not** interchangeable with GT | GTX | G-Series
- Some options may require modifications to the exhaust system to fit
- Always double check before purchasing



Turbo PN

Supercore and turbine housing are fully assembled and calibrated by Garrett with a 0.5 Bar actuator. The assembly and calibration make it a Turbo. Only offered with internally wastegated turbine housings. Gasket kit is included.

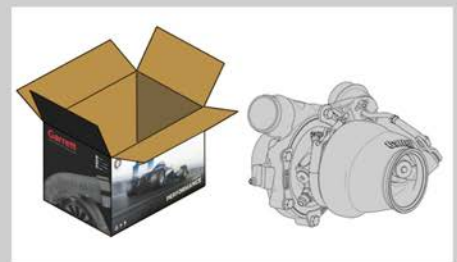

Assembly Kit PN

One part number includes the supercore and turbine kit, in individual boxes, not assembled to make ordering easier. Gasket kit included. Tools and assembly required to connect the supercore to the turbine housing.



G-SERIES II

Whether you're a kit maker or an owner of a high-performance vehicle, now you can harness the power of motorsport legends and experience the durability of champions in your car with the NEW G-Series II universal Performance Turbos line from Garrett. Designed with the same quality and craftsmanship that has powered motorsport legends for over 4 decades. G-Series II turbochargers are available in multiple frame sizes to suit your individual needs, whether as a complete new turbo or as a CHRA swap to upgrade your G-Series I Turbo.



Power Of Legends. Durability Of Champions.

Only the best of the best qualify to compete in prestigious Motorsport races, like the 24 Hours of Le Mans. It takes a combination of unparalleled skill, relentless hard work, and cutting-edge technology to reach the podium and achieve immortality. Those who succeed become legends.

For over 40 years, Garrett has been the name behind the legends of motorsport, powering the winners of the most prestigious races, including the Le Mans champions of the last 25 years. Our turbochargers are engineered by a team of 1300 engineers and tested across five R&D centers around the world, to deliver unmatched performance and reliability.



G-Series II G25-585

Horsepower: 300 - 585
Displacement: 1.4L - 3.0L

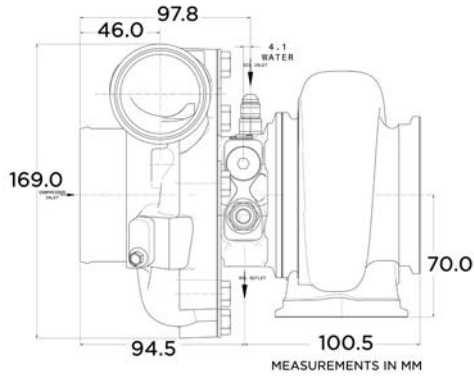

COMPRESSOR MAP

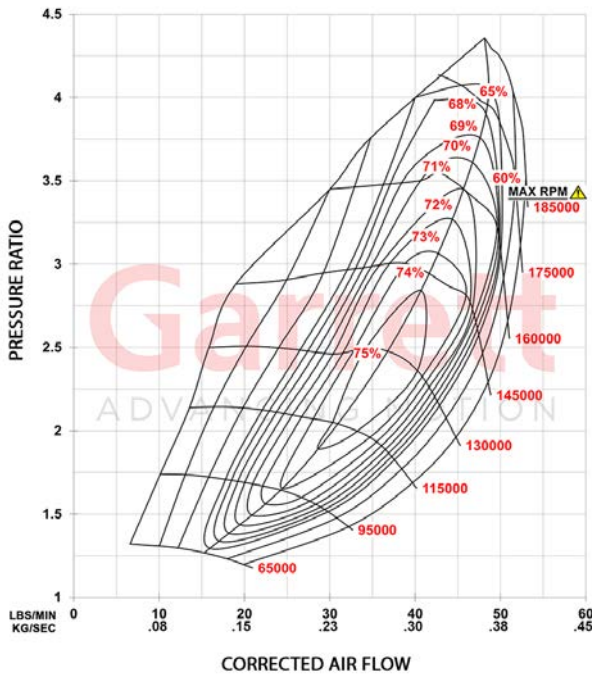

FEATURES:

- ◆ NEW COMPRESSOR AERO INCREASES POWER AND PERFORMANCE
- ◆ UP TO 10% HIGHER COMPRESSOR FLOW COMPARED TO G-SERIES GEN I AT PEAK PRESSURE RATIO AND PEAK TURBO RPM
- ◆ DIRECT UPGRADE PATH FOR GEN I CUSTOMERS WITH JUST A CHRA SWAP
- ◆ UTILIZES GEN I COMPRESSOR AND TURBINE HOUSINGS
- ◆ STANDARD AND REVERSE ROTATION CONFIGURATIONS
- ◆ TURBINE WHEEL CONSTRUCTED OF MAR-M ALLOY RATED UP TO 1050°C
- ◆ OIL RESTRICTOR AND WATER FITTINGS INCLUDED

EXHAUST FLOW CHART

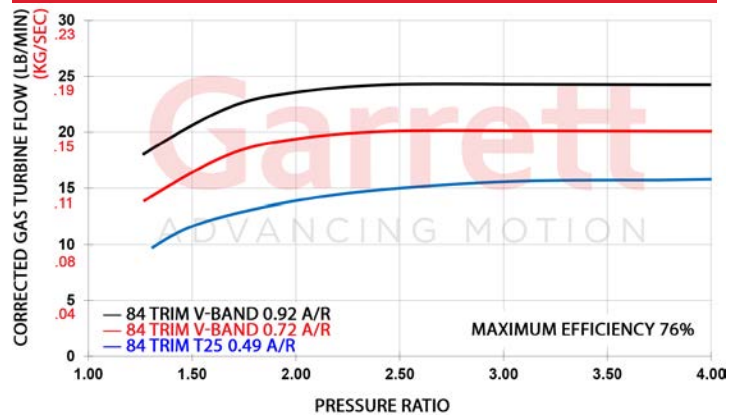

G-Series II G25-585	Compressor				Inducer	Turbine	
	Inducer	Exducer	Trim	A/R		Exducer	Trim
HP: 300-585 Disp: 1.4L-3.0L	48mm	60mm	65	A/R	54mm	49mm	84
Supercore	PN						
Standard Rotation	934075-5001S						
Reverse Rotation	934114-5001S						
CHRA	PN						
Standard Rotation	934074-5001S						
Reverse Rotation	934113-5001S						
Turbo: Standard Rotation	PN	A/R	Inlet	Outlet	Wastegate	Divided	
Assembled and calibrated with 0.5 bar actuator	934076-5001S	0.49	T25	V-Band	Internal	N	
	934076-5002S	0.72	V-Band	V-Band	Internal	N	
	934076-5003S	0.92	V-Band	V-Band	Internal	N	
Turbo: Reverse Rotation	PN	A/R	Inlet	Outlet	Wastegate	Divided	
See note above	934115-5001S	0.72	V-Band	V-Band	Internal	N	
	934115-5002S	0.92	V-Band	V-Band	Internal	N	
Turbine Kits Standard Rotation	PN	A/R	Inlet	Outlet	Wastegate	Divided	
	740902-0069	0.72	V-Band	V-Band	External	N	
	740902-0068	0.92	V-Band	V-Band	External	N	
	740902-0076	0.72	V-Band	V-Band	Internal	N	
	740902-0077	0.92	V-Band	V-Band	Internal	N	
	740902-0080	0.49	T25	V-Band	Internal	N	
Turbine Kits Reverse Rotation	PN	A/R	Inlet	Outlet	Wastegate	Divided	
	740902-0073	0.72	V-Band	V-Band	External	N	
	740902-0074	0.92	V-Band	V-Band	External	N	
	740902-0078	0.72	V-Band	V-Band	Internal	N	
	740902-0079	0.92	V-Band	V-Band	Internal	N	

G-Series II G25-700

Horsepower: 350 - 700
Displacement: 1.4L - 3.0L

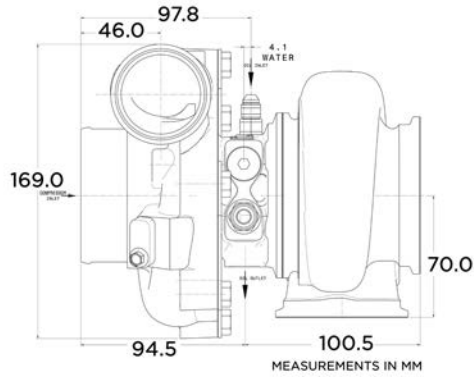

FEATURES:

- ◆ NEW COMPRESSOR AERO INCREASES POWER AND PERFORMANCE
- ◆ UP TO 10% HIGHER COMPRESSOR FLOW COMPARED TO G-SERIES GEN I AT PEAK PRESSURE RATIO AND PEAK TURBO RPM
- ◆ DIRECT UPGRADE PATH FOR GEN I CUSTOMERS WITH JUST A CHRA SWAP
- ◆ UTILIZES GEN I COMPRESSOR AND TURBINE HOUSINGS
- ◆ STANDARD AND REVERSE ROTATION CONFIGURATIONS
- ◆ TURBINE WHEEL CONSTRUCTED OF MAR-M ALLOY RATED UP TO 1050°C
- ◆ OIL RESTRICTOR AND WATER FITTINGS INCLUDED

COMPRESSOR MAP

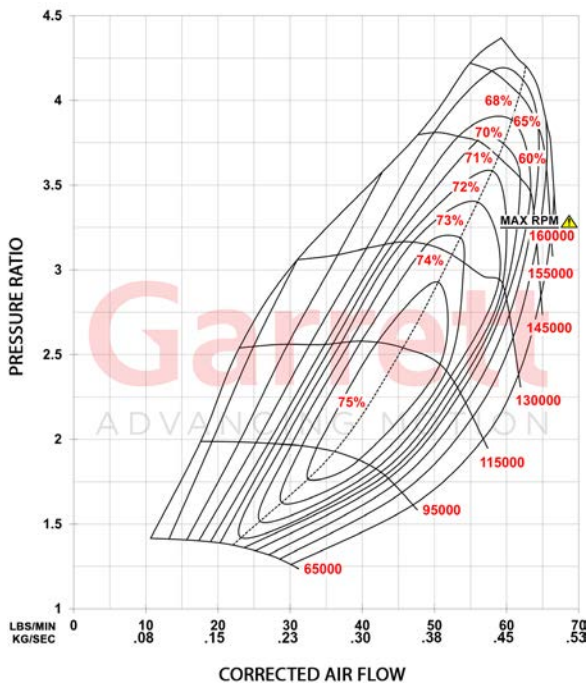

EXHAUST FLOW CHART

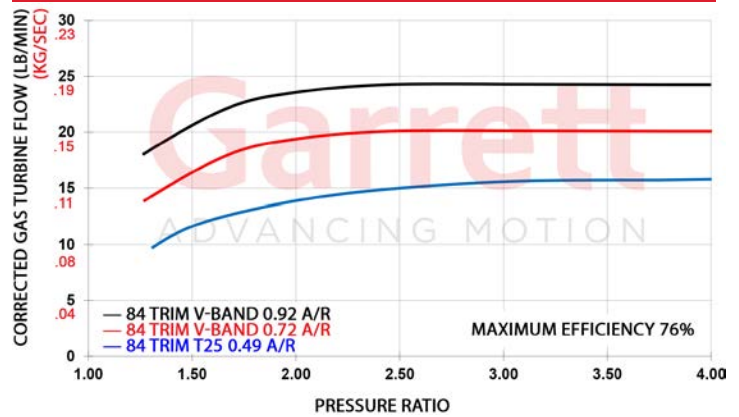

G-Series II G25-700 HP: 350-700 Disp: 1.4L-3.0L	Compressor				Inducer 54mm	Turbine Exducer 49mm	Trim 84
	Inducer 54mm	Exducer 67mm	Trim 65	A/R 0.70			
Supercore	PN						
Standard Rotation	934075-5002S						
Reverse Rotation	934114-5002S						
CHRA	PN						
Standard Rotation	934074-5002S						
Reverse Rotation	934113-5002S						
Turbo: Standard Rotation	PN	A/R	Inlet	Outlet	Wastegate	Divided	
Assembled and calibrated with 0.5 bar actuator	934076-5004S	0.49	T25	V-Band	Internal	N	
	934076-5005S	0.72	V-Band	V-Band	Internal	N	
	934076-5006S	0.92	V-Band	V-Band	Internal	N	
Turbo: Reverse Rotation	PN	A/R	Inlet	Outlet	Wastegate	Divided	
See note above	934115-5003S	0.72	V-Band	V-Band	Internal	N	
	934115-5004S	0.92	V-Band	V-Band	Internal	N	
Turbine Kits Standard Rotation	PN	A/R	Inlet	Outlet	Wastegate	Divided	
	740902-0069	0.72	V-Band	V-Band	External	N	
	740902-0068	0.92	V-Band	V-Band	External	N	
	740902-0076	0.72	V-Band	V-Band	Internal	N	
	740902-0077	0.92	V-Band	V-Band	Internal	N	
	740902-0080	0.49	T25	V-Band	Internal	N	
Turbine Kits Reverse Rotation	PN	A/R	Inlet	Outlet	Wastegate	Divided	
	740902-0073	0.72	V-Band	V-Band	External	N	
	740902-0074	0.92	V-Band	V-Band	External	N	
	740902-0078	0.72	V-Band	V-Band	Internal	N	
	740902-0079	0.92	V-Band	V-Band	Internal	N	

G-Series II G30-725

Horsepower: 350 - 725
Displacement: 2.0L - 3.5L

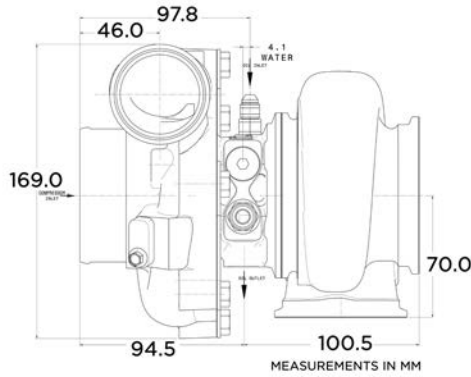

COMPRESSOR MAP

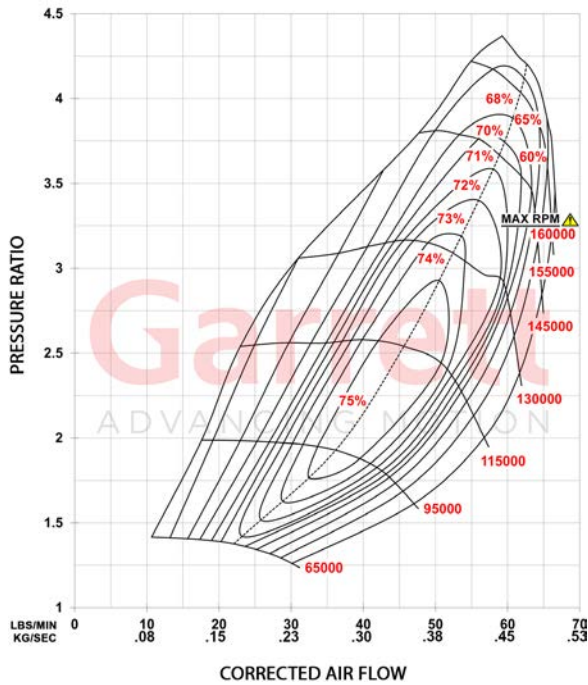

FEATURES:

- ◆ NEW COMPRESSOR AERO INCREASES POWER AND PERFORMANCE
- ◆ UP TO 10% HIGHER COMPRESSOR FLOW COMPARED TO G-SERIES GEN I AT PEAK PRESSURE RATIO AND PEAK TURBO RPM
- ◆ DIRECT UPGRADE PATH FOR GEN I CUSTOMERS WITH JUST A CHRA SWAP
- ◆ UTILIZES GEN I COMPRESSOR AND TURBINE HOUSINGS
- ◆ STANDARD AND REVERSE ROTATION CONFIGURATIONS
- ◆ TURBINE WHEEL CONSTRUCTED OF MAR-M ALLOY RATED UP TO 1050°C
- ◆ OIL RESTRICTOR AND WATER FITTINGS INCLUDED

EXHAUST FLOW CHART

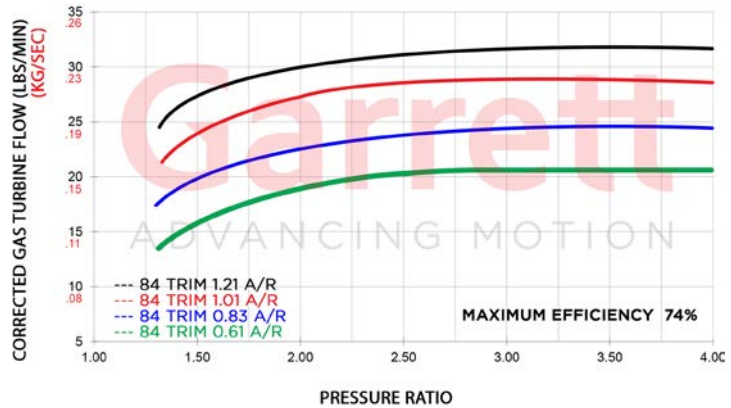

G-Series II G30-725	Compressor				Turbine		
	Inducer	Exducer	Trim	A/R	Inducer	Exducer	Trim
HP: 350-725 Disp: 2.0L-3.5L	54mm	67mm	65	0.70	60mm	55mm	84
Supercore	PN						
Standard Rotation	934117-5001S						
Reverse Rotation	934121-5001S						
CHRA	PN						
Standard Rotation	934116-5001S						
Reverse Rotation	934120-5001S						
Turbo: Standard Rotation	PN	A/R	Inlet	Outlet	Wastegate	Divided	
Assembled and calibrated	934118-5001S	0.83	V-Band	V-Band	Internal	N	
with 0.5 bar actuator	934118-5002S	1.01	V-Band	V-Band	Internal	N	
Turbine Kits Standard Rotation	PN	A/R	Inlet	Outlet	Wastegate	Divided	
	740902-0092	1.06	T4	V-Band	External	Y	
	740902-0090	0.83	T3	V-Band	External	N	
	740902-0091	1.01	T3	V-Band	External	N	
	740902-0086	0.61	V-Band	V-Band	External	N	
	740902-0087	0.83	V-Band	V-Band	External	N	
	740902-0088	1.01	V-Band	V-Band	External	N	
	740902-0089	1.21	V-Band	V-Band	External	N	
	740902-0094	0.83	V-Band	V-Band	Internal	N	
	740902-0095	1.01	V-Band	V-Band	Internal	N	
Turbine Kits Reverse Rotation	PN	A/R	Inlet	Outlet	Wastegate	Divided	
	740902-0100	0.83	T3	V-Band	External	N	
	740902-0101	1.01	T3	V-Band	External	N	
	740902-0096	0.61	V-Band	V-Band	External	N	
	740902-0097	0.83	V-Band	V-Band	External	N	
	740902-0098	1.01	V-Band	V-Band	External	N	
	740902-0099	1.21	V-Band	V-Band	External	N	

G-Series II G30-825

Horsepower: 475 - 825
Displacement: 2.0L - 3.5L

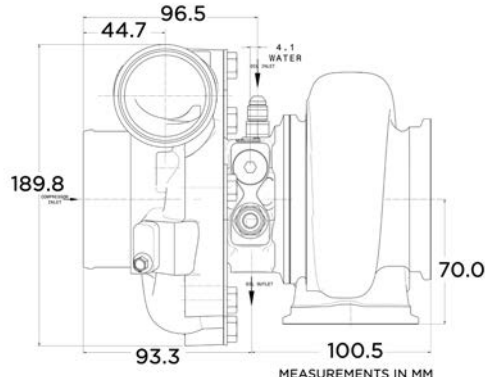

COMPRESSOR MAP

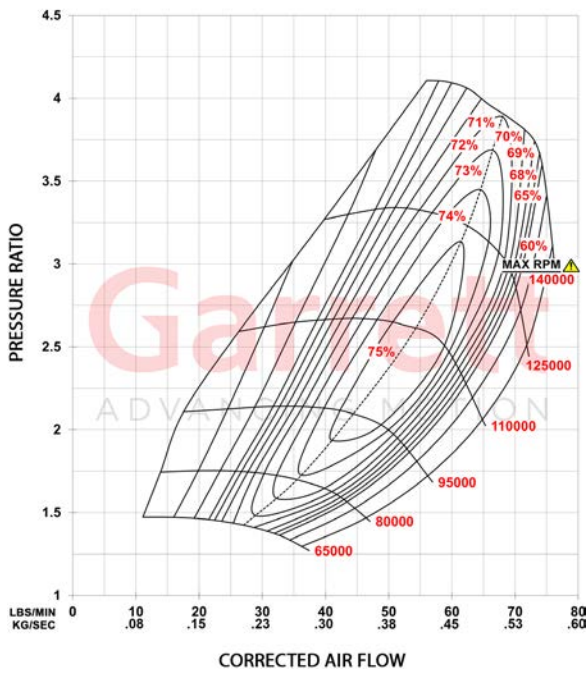

FEATURES:

- ◆ NEW COMPRESSOR AERO INCREASES POWER AND PERFORMANCE
- ◆ UP TO 10% HIGHER COMPRESSOR FLOW COMPARED TO G-SERIES GEN I AT PEAK PRESSURE RATIO AND PEAK TURBO RPM
- ◆ DIRECT UPGRADE PATH FOR GEN I CUSTOMERS WITH JUST A CHRA SWAP
- ◆ UTILIZES GEN I COMPRESSOR AND TURBINE HOUSINGS
- ◆ STANDARD AND REVERSE ROTATION CONFIGURATIONS
- ◆ TURBINE WHEEL CONSTRUCTED OF MAR-M ALLOY RATED UP TO 1050°C
- ◆ OIL RESTRICTOR AND WATER FITTINGS INCLUDED

EXHAUST FLOW CHART

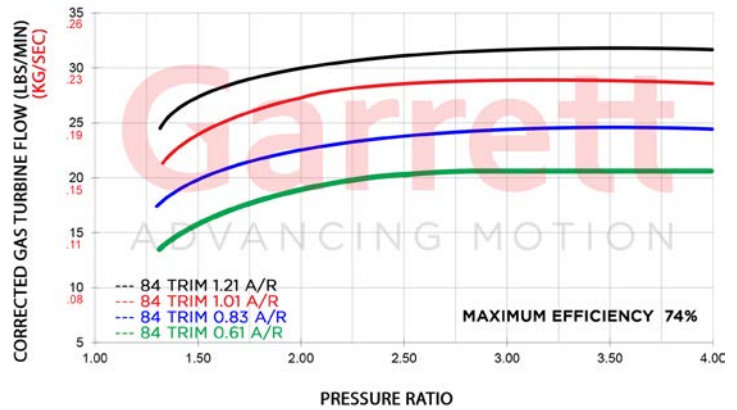

G-Series II G30-825	Compressor				Turbine		
	Inducer	Exducer	Trim	A/R	Inducer	Exducer	Trim
HP: 475-825 Disp: 2.0L-3.5L	58mm	71mm	65	0.72	60mm	55mm	84
Supercore	PN						
Standard Rotation	934117-5002S						
Reverse Rotation	934121-5002S						
CHRA	PN						
Standard Rotation	934116-5002S						
Reverse Rotation	934120-5002S						
Turbo: Standard Rotation	PN	A/R	Inlet	Outlet	Wastegate	Divided	
Assembled and calibrated with 0.5 bar actuator	934118-5003S	0.83	V-Band	V-Band	Internal	N	
	934118-5004S	1.01	V-Band	V-Band	Internal	N	
Turbine Kits Standard Rotation	PN	A/R	Inlet	Outlet	Wastegate	Divided	
	740902-0092	1.06	T4	V-Band	External	Y	
	740902-0090	0.83	T3	V-Band	External	N	
	740902-0091	1.01	T3	V-Band	External	N	
	740902-0086	0.61	V-Band	V-Band	External	N	
	740902-0087	0.83	V-Band	V-Band	External	N	
	740902-0088	1.01	V-Band	V-Band	External	N	
	740902-0089	1.21	V-Band	V-Band	External	N	
	740902-0094	0.83	V-Band	V-Band	Internal	N	
	740902-0095	1.01	V-Band	V-Band	Internal	N	
Turbine Kits Reverse Rotation	PN	A/R	Inlet	Outlet	Wastegate	Divided	
	740902-0100	0.83	T3	V-Band	External	N	
	740902-0101	1.01	T3	V-Band	External	N	
	740902-0096	0.61	V-Band	V-Band	External	N	
	740902-0097	0.83	V-Band	V-Band	External	N	
	740902-0098	1.01	V-Band	V-Band	External	N	
	740902-0099	1.21	V-Band	V-Band	External	N	

G-Series II G35-990

Horsepower: 550 - 990
Displacement: 2.0L - 5.5L

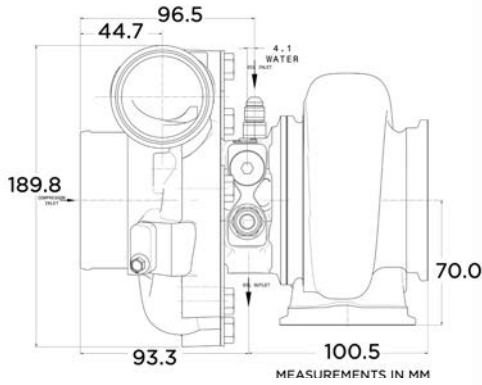

COMPRESSOR MAP

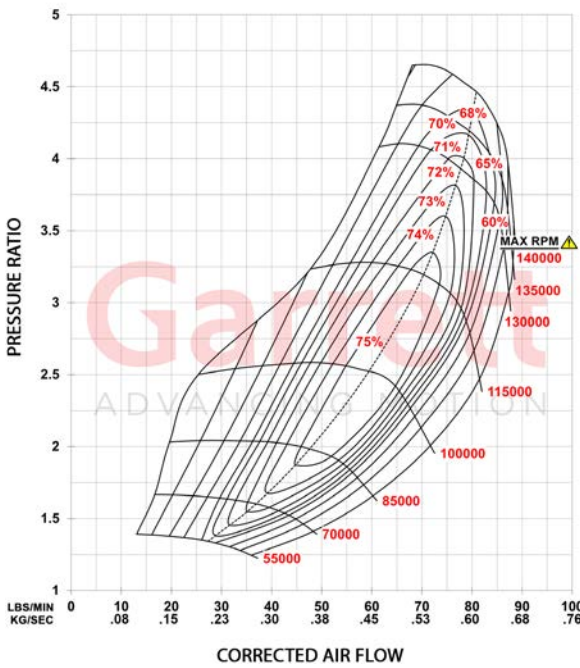

FEATURES:

- ◆ NEW COMPRESSOR AERO INCREASES POWER AND PERFORMANCE
- ◆ UP TO 10% HIGHER COMPRESSOR FLOW COMPARED TO G-SERIES GEN I AT PEAK PRESSURE RATIO AND PEAK TURBO RPM
- ◆ DIRECT UPGRADE PATH FOR GEN I CUSTOMERS WITH JUST A CHRA SWAP
- ◆ UTILIZES GEN I COMPRESSOR AND TURBINE HOUSINGS
- ◆ STANDARD AND REVERSE ROTATION CONFIGURATIONS
- ◆ TURBINE WHEEL CONSTRUCTED OF MAR-M ALLOY RATED UP TO 1050°C
- ◆ OIL RESTRICTOR AND WATER FITTINGS INCLUDED

EXHAUST FLOW CHART

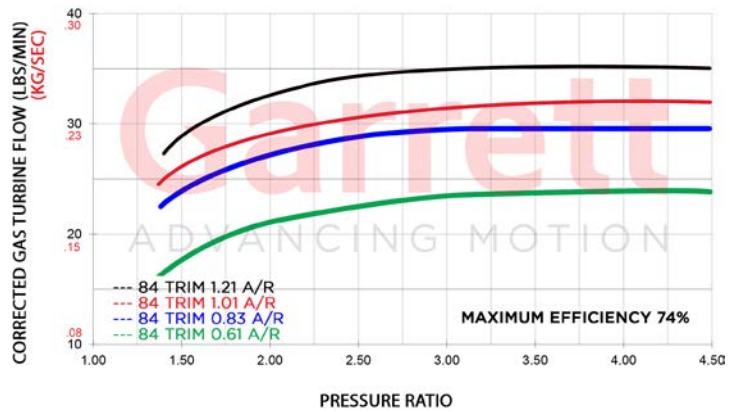

G-Series II G35-990 HP: 550-990 Disp: 2.0L-5.5L	Compressor				Inducer 68mm	Turbine Exducer 62mm	Trim 84
	Inducer 62mm	Exducer 76mm	Trim 65	A/R 0.72			
Supercore	PN						
Standard Rotation	934123-5001S						
Reverse Rotation	934126-5001S						
CHRA	PN						
Standard Rotation	934122-5001S						
Reverse Rotation	934125-5001S						
Turbo: Standard Rotation	PN	A/R	Inlet	Outlet	Wastegate	Divided	
Assembled and calibrated	934124-5001S	0.83	V-Band	V-Band	Internal	N	
with 0.5 bar actuator	934124-5002S	1.01	V-Band	V-Band	Internal	N	
Turbine Kits Standard Rotation	PN	A/R	Inlet	Outlet	Wastegate	Divided	
	740902-0108	1.06	T4	V-Band	External	Y	
	740902-0106	0.83	T3	V-Band	External	N	
	740902-0107	1.01	T3	V-Band	External	N	
	740902-0102	0.61	V-Band	V-Band	External	N	
	740902-0103	0.83	V-Band	V-Band	External	N	
	740902-0104	1.01	V-Band	V-Band	External	N	
	740902-0105	1.21	V-Band	V-Band	External	N	
	740902-0110	0.83	V-Band	V-Band	Internal	N	
	740902-0111	1.01	V-Band	V-Band	Internal	N	
Turbine Kits Reverse Rotation	PN	A/R	Inlet	Outlet	Wastegate	Divided	
	740902-0116	0.83	T3	V-Band	External	N	
	740902-0117	1.01	T3	V-Band	External	N	
	740902-0112	0.61	V-Band	V-Band	External	N	
	740902-0113	0.83	V-Band	V-Band	External	N	
	740902-0114	1.01	V-Band	V-Band	External	N	
	740902-0115	1.21	V-Band	V-Band	External	N	



G-SERIES

Garrett G-Series turbochargers feature the latest innovations in turbocharger technology. This clean sheet product has our highest performing compressor and turbine aero to date. Countless engineering hours have been spent to create the perfect blend of efficiency and performance in a compact package. Advanced features tailored to meet the demands of hard core competitors making G-Series the most powerful turbochargers on the market.



The AMS Performance Prime Cuts Chop Shop ALPHA OMEGA Huracan project was started with one goal in mind, to build the world's fastest Lamborghini. As an authorized Performance Distributor of Garrett Motion, AMS has firsthand testing data and on-track experience to know what works and what doesn't. The car has utilized a number of different Garrett turbos throughout its stages to meet the horsepower needs to go faster and faster. From GTX3584RS, G35-1050, G42-1200 Compact, and now a pair of G42-1450 turbos with a 79mm compressor which allows the car to make over **2000 wheel horsepower**.



Reliability is always a priority when working in a competitive racing environment. With an entire race team, vehicle transporter, tools, tires, consumables, and more sent to support the vehicle at race events across the country, teams cannot afford to sit on the sidelines due to a mechanical failure. The testing and inspection procedures that Garrett implements in their manufacturing processes are second to none in the industry and is why they are well known as offering the most reliable turbocharger solutions on the market. This reliability has allowed the AMS team to remain competitive in numerous events as well as set the world record of 7.33 sec @ 194 mph quarter mile with the ALPHA OMEGA Huracan.

A TURN AHEAD OF THE COMPETITION



Product Features	G25-550	G25-660	G30-660	G30-770	G30-900	G35-900	G35-1050	G40-900	G40-1150	G42-1200C	G42-1200	G42-1450	G45-1125	G45-1350	G45-1500	G45-1600
Displacement Range	1.4L-3.0L		2.0L-3.5L			2.0L-5.5L		2.0L-6.0L		2.0L-7.0L			2.0L-8.0L			
Turbine Inducer	54mm		60mm			68mm		77mm		82mm			89mm			
Turbine Exducer	49mm		55mm			62mm		70mm		75mm			82mm			
Horsepower Range	300-550	350-660	350-660	475-770	550-900	550-900	700-1050	500-900	500-1150	475-1200	475-1200	525-1450	600-1125	650-1350	750-1500	750-1600
Comp Ind (mm)	48	54	54	58	62	62	68	62	71	73	73	79	67	72	76	80
Comp Exd (mm)	60	67	67	71	76	76	84	88	88	91	91	98	102	102	109	110
Standard Rotation	*	*	*	*	*	*	*	*	*	*	*	*	*	*	*	*
Reverse Rotation	*	*	*	*	*	*	*	*	*	*	*	*	*	*	*	*
Internally Wastegated Options	*	*	*	*	*	*	*	*	*	*	*	*	*	*	*	*
Speed Sensor Port	*	*	*	*	*	*	*	*	*	*	*	*	*	*	*	*
Water Cooled	*	*	*	*	*	*	*	*	*	*	*	*	*	*	*	*
Dual Ceramic Ball Bearing	*	*	*	*	*	*	*	*	*	*	*	*	*	*	*	*
Machined Pressure Port	*	*	*	*	*	*	*	*	*	*	*	*	*	*	*	*
Twin Piston Rings	*	*	*	*	*	*	*	*	*	*	*	*	*	*	*	*
Ported Shroud	*	*	*	*	*	*	*	*	*	*	*	*	*	*	*	*
Stainless Steel Turbine Housing	*	*	*	*	*	*	*	*	*	*	*	*	*	*	*	*
Inconel Turbine Wheel	*	*	*	*	*	*	*	*	*	*	*	*	*	*	*	*
Mar-M Turbine Wheel	*	*	*	*	*	*	*	*	*	*	*	*	*	*	*	*
T25 Inlet Turbine Housing	*	*	*	*	*	*	*	*	*	*	*	*	*	*	*	*
V-Band 3" 76mm Inlet Turbine	*	*	*	*	*	*	*	*	*	*	*	*	*	*	*	*
T3 Inlet Turbine Housing	*	*	*	*	*	*	*	*	*	*	*	*	*	*	*	*
T4 Divided Inlet Turbine Housing	*	*	*	*	*	*	*	*	*	*	*	*	*	*	*	*
V-Band 3.6" 92mm Inlet Turbine	*	*	*	*	*	*	*	*	*	*	*	*	*	*	*	*
T6 Inlet Turbine Housing	*	*	*	*	*	*	*	*	*	*	*	*	*	*	*	*
V-Band 4.25" 108mm Inlet Turbine	*	*	*	*	*	*	*	*	*	*	*	*	*	*	*	*

INTERNALLY WASTEGATED

configurations are available in standard rotation in G25|G30|G35 and reverse rotation in G25. Turbochargers are fully assembled and calibrated with a 0.5 bar actuator.



STANDARD AND REVERSE ROTATION

turbochargers are offered in the G-Series product line up to G35 frame sizes. Reverse rotation turbochargers are mirrored in appearance and rotate counter clockwise. It is a popular option for twin turbo systems to maintain symmetry in the engine compartment. Reverse rotation components are not interchangeable with standard rotation components and housings. G25 | G30 | G35



"We have been able to capture **24 total track records"**

C6 Corvette featured on the cover page

10 Questions with Feras Qartoumy:

1. What made you decide to start racing?

I grew up at the track watching my father race. He would take me with him to help change tires and brakes. I probably did more harm than good but thanks to my father I not only developed a passion for racing but it's also where I got my mindset of never giving up!

2. Tell us about your Corvette (YMM, engine, power, turbos, etc.)

2008 Corvette Z06. LME 427. RHS Block Brodix Heads. Garrett G35-900's 1200 whp on kill... Penske Racing 8300's Alcon 6 piston Brakes Front 4 piston Rear. Motec M150 PPG 1:1 6th gear sequential. Yokohama A005 tires. Bosch Motorsport ABS

3. You have made a big name for yourself the last 2 years. Tell us about all the accomplishments.

The past two years have been absolutely unbelievable. With the help from all my amazing partners we have been able to capture 24 total track records in 2020 and 2021 combined! We were also able to place 1st at every event but 1!

4. Do you have a favorite memory?

My favorite memory would have to be capturing the production car record at Road America with a 2:04. The car was overheating by turn 5 and somehow allowed me to keep pushing and finish the lap. Made me feel like both myself and the car wanted it and stuck it out till the end.

5. What is your favorite race track?

Hands down Circuit of the Americas

6. What tips would you give someone who is just starting out in racing?

Have fun. Many people take racing too serious. Never lose sight of how lucky you are to be on track and doing something you are passionate about.

7. Tell us what you like about the different turbo combos and how they have helped you in different ways?

What I like mostly about them is how easily interchangeable they are. I was able to literally just swap turbos and not have to change hot side or charge piping I think that for one making it so easy to test and change out turbos per event is amazing. Also I have noticed I can reach my target HP very easily with all. And can spool sooner by stepping down from a g 35-900 to a g 30-900 but yet still have all the tq and hp I want up top. The g35 seems to be best suited for bigger tracks that have higher speed turns and longer straights. Where the g30 is utilized in smaller tracks where lower speeds are not allowing the turbos to spool as quickly.

8. Your car has some serious aero, how much downforce does it make and how do you know when to adjust it for different tracks?

Currently the car is making north of 3200 lbs of downforce. I have been making slight adjustment to the car per event. I have seen gains and the pros of using high df but also seen cons. That is why at Long Beach and Road America I opted to use a medium downforce package. I am in the process of designing aero with Verus specific to the car based on the data I have acquired over this past year. We just finished scanning the car and have ran it through a few sims now. Big things to come...

9. What's in store for 2022?

For 2022 I'd love to start traveling outside the us and make my way to Australia. I plan on adding to my list of track records and hopefully claim a few more national titles. We have some new aero we are developing in CAD and hopefully a bit more power...

10. Where can people find you on social media?

I pretty much do everything on Instagram. You can find me at @feras_qartoumy I post almost all my in-car on YouTube at Feras Qartoumy.

Garrett G25-550

Horsepower: 300 - 550
Displacement: 1.4L - 3.0L

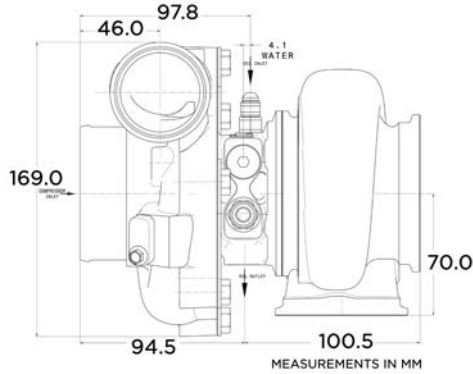

COMPRESSOR MAP

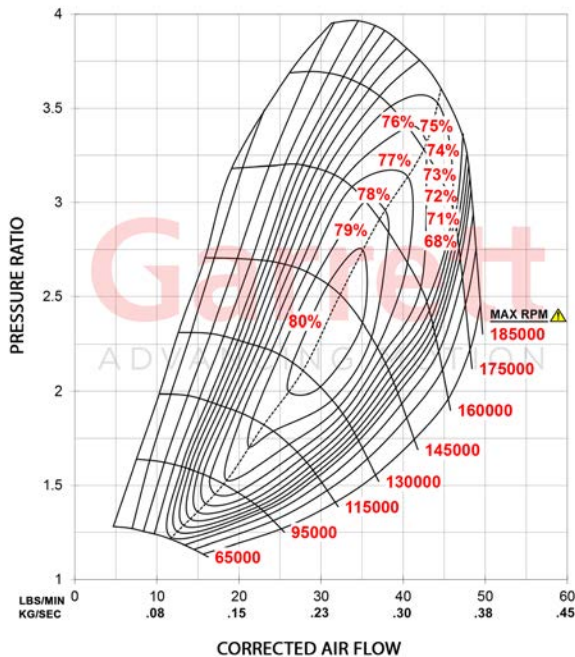

FEATURES:

- ◆ G-SERIES COMPRESSOR AERODYNAMICS FOR MAXIMUM HP
- ◆ G-SERIES TURBINE WHEEL AERO WITH IMPROVED EFFICIENCY
- ◆ STANDARD AND REVERSE ROTATION CONFIGURATIONS
- ◆ TURBINE WHEEL CONSTRUCTED OF MAR-M ALLOY RATED UP TO 1050°C
- ◆ FULLY MACHINED SPEED SENSOR AND PRESSURE PORTS
- ◆ OIL RESTRICTOR AND WATER FITTINGS INCLUDED

EXHAUST FLOW CHART

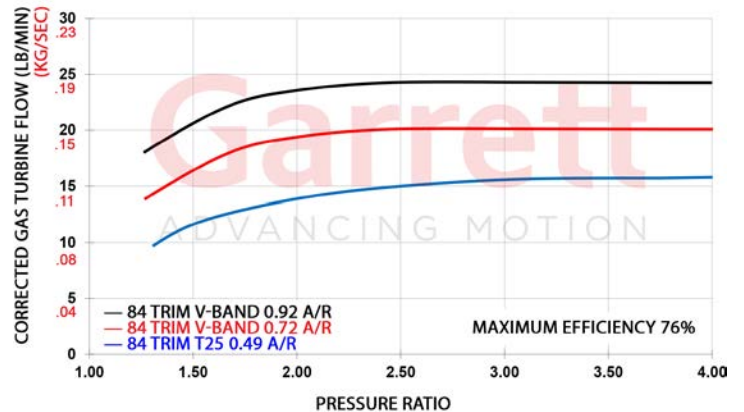

G25-550 HP: 300-550 Disp: 1.4L-3.0L	Compressor				Turbine		
	Inducer 48mm	Exducer 60mm	Trim 65	A/R 0.70	Inducer 54mm	Exducer 49mm	Trim 84
Turbo: Standard Rotation	PN		A/R	Inlet	Outlet	Wastegate	Divided
Assembled and calibrated with 0.5 bar actuator	877895-5001S		0.49	T25	V-Band	Internal	N
	877895-5003S		0.72	V-Band	V-Band	Internal	N
	877895-5004S		0.92	V-Band	V-Band	Internal	N
Turbo: Reverse Rotation	PN		A/R	Inlet	Outlet	Wastegate	Divided
See note above	877895-5007S		0.72	V-Band	V-Band	Internal	N
	877895-5008S		0.92	V-Band	V-Band	Internal	N
Turbine Kits Standard Rotation	PN		A/R	Inlet	Outlet	Wastegate	Divided
Internal Wastegate	740902-0076		0.72	V-Band	V-Band	Internal	N
	740902-0077		0.92	V-Band	V-Band	Internal	N
	740902-0080		0.49	T25	V-Band	Internal	N
Turbine Kits Reverse Rotation	PN		A/R	Inlet	Outlet	Wastegate	Divided
Internal Wastegate	740902-0078		0.72	V-Band	V-Band	Internal	N
	740902-0079		0.92	V-Band	V-Band	Internal	N
Supercore	PN						
Standard Rotation	858161-5002S						
Reverse Rotation	871388-5001S						
Turbine Kits Standard Rotation	PN		A/R	Inlet	Outlet	Wastegate	Divided
Free Float	740902-0069		0.72	V-Band	V-Band	External	N
	740902-0068		0.92	V-Band	V-Band	External	N
Turbine Kits Reverse Rotation	PN		A/R	Inlet	Outlet	Wastegate	Divided
Free Float	740902-0073		0.72	V-Band	V-Band	External	N
	740902-0074		0.92	V-Band	V-Band	External	N

Garrett G25-660

Horsepower: 350 - 660
Displacement: 1.4L - 3.0L

Garrett
ADVANCING MOTION

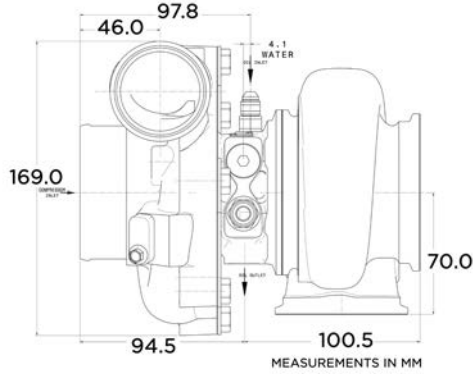

COMPRESSOR MAP

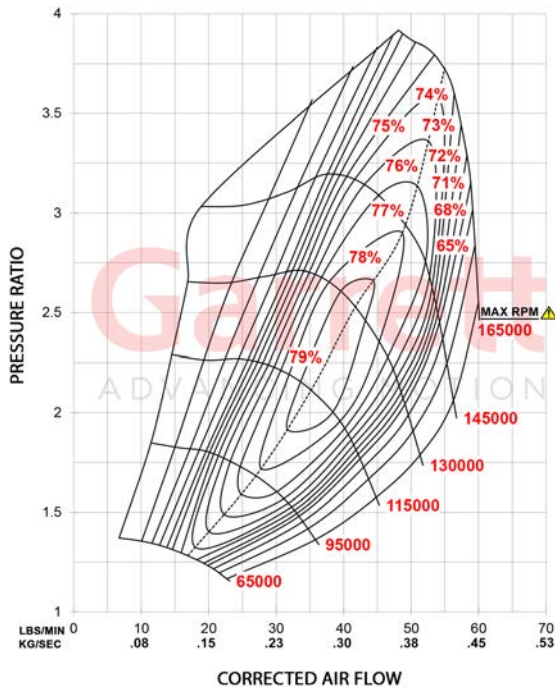

FEATURES:

- ◆ G-SERIES COMPRESSOR AERODYNAMICS FOR MAXIMUM HP
- ◆ G-SERIES TURBINE WHEEL AERO WITH IMPROVED EFFICIENCY
- ◆ STANDARD AND REVERSE ROTATION CONFIGURATIONS
- ◆ TURBINE WHEEL CONSTRUCTED OF MAR-M ALLOY RATED UP TO 1050°C
- ◆ FULLY MACHINED SPEED SENSOR AND PRESSURE PORTS
- ◆ OIL RESTRICTOR AND WATER FITTINGS INCLUDED

EXHAUST FLOW CHART

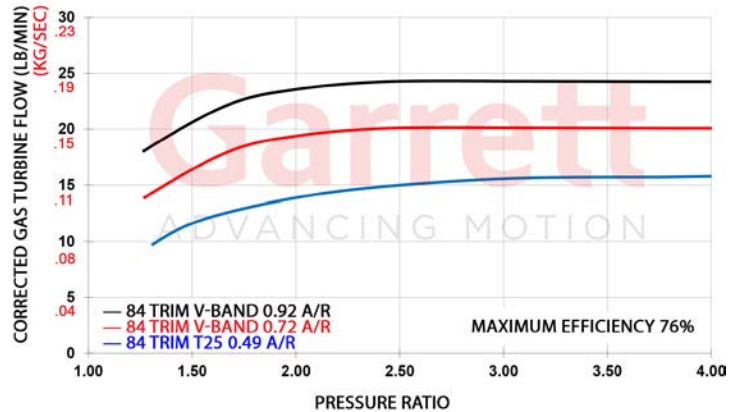

G25-660 HP: 350-660 Disp: 1.4L-3.0L	Compressor				Turbine		
	Inducer 54mm	Exducer 67mm	Trim 65	A/R 0.70	Inducer 54mm	Exducer 49mm	Trim 84
Turbo: Standard Rotation	PN	PN	A/R	Inlet	Outlet	Wastegate	Divided
Assembled and calibrated with 0.5 bar actuator	877895-5002S		0.49	T25	V-Band	Internal	N
	877895-5005S		0.72	V-Band	V-Band	Internal	N
	877895-5006S		0.92	V-Band	V-Band	Internal	N
Turbo: Reverse Rotation	PN	PN	A/R	Inlet	Outlet	Wastegate	Divided
See note above	877895-5009S		0.72	V-Band	V-Band	Internal	N
	877895-5010S		0.92	V-Band	V-Band	Internal	N
Turbine Kits Standard Rotation	PN	PN	A/R	Inlet	Outlet	Wastegate	Divided
Internal Wastegate	740902-0076		0.72	V-Band	V-Band	Internal	N
	740902-0077		0.92	V-Band	V-Band	Internal	N
	740902-0080		0.49	T25	V-Band	Internal	N
Turbine Kits Reverse Rotation	PN	PN	A/R	Inlet	Outlet	Wastegate	Divided
Internal Wastegate	740902-0078		0.72	V-Band	V-Band	Internal	N
	740902-0079		0.92	V-Band	V-Band	Internal	N
Supercore	PN	PN	PN	PN	PN	PN	PN
Standard Rotation	858161-5003S						
Reverse Rotation	871388-5002S						
Turbine Kits Standard Rotation	PN	PN	A/R	Inlet	Outlet	Wastegate	Divided
Free Float	740902-0069		0.72	V-Band	V-Band	External	N
	740902-0068		0.92	V-Band	V-Band	External	N
Turbine Kits Reverse Rotation	PN	PN	A/R	Inlet	Outlet	Wastegate	Divided
Free Float	740902-0073		0.72	V-Band	V-Band	External	N
	740902-0074		0.92	V-Band	V-Band	External	N

Garrett G30-660

Horsepower: 350 - 660
Displacement: 2.0L - 3.5L

Garrett
ADVANCING MOTION

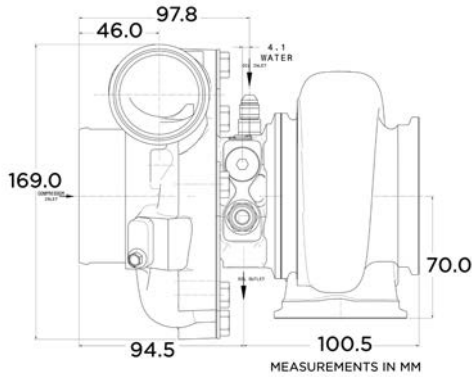

COMPRESSOR MAP

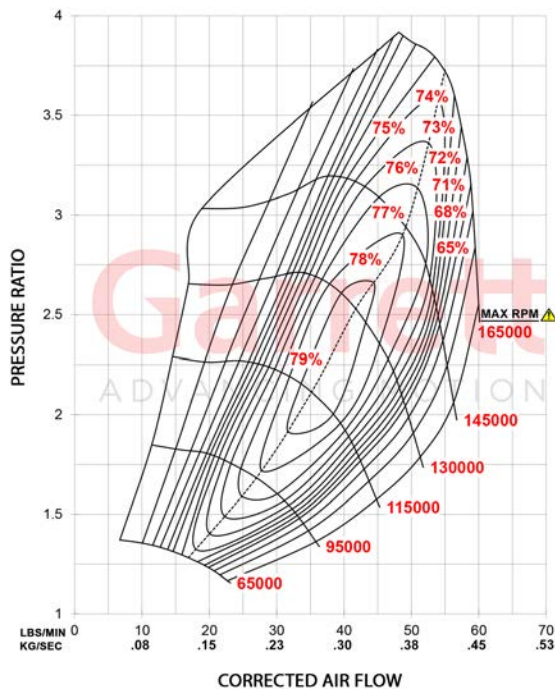

REVERSE ROTATION

FEATURES:

- ◆ G-SERIES COMPRESSOR AERODYNAMICS FOR MAXIMUM HP
- ◆ G-SERIES TURBINE WHEEL AERO WITH IMPROVED EFFICIENCY
- ◆ STANDARD AND REVERSE ROTATION CONFIGURATIONS
- ◆ TURBINE WHEEL CONSTRUCTED OF MAR-M ALLOY RATED UP TO 1050°C
- ◆ FULLY MACHINED SPEED SENSOR AND PRESSURE PORTS
- ◆ OIL RESTRICTOR AND WATER FITTINGS INCLUDED

EXHAUST FLOW CHART

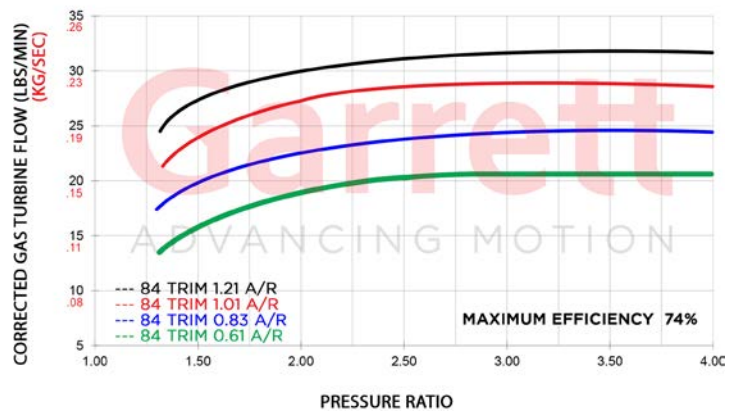

G30-660 HP: 350-660 Disp: 2.0L-3.5L	Compressor				Turbine				
	Inducer 54mm	Exducer 67mm	Trim 65	A/R 0.70	Inducer 60mm	Exducer 55mm	Trim 84		
Turbo: Standard Rotation	PN				Inlet	Outlet	Wastegate	Divided	
Assembled and calibrated	880704-5002S		0.83	V-Band	V-Band	Internal	N		
with 0.5 bar actuator	880704-5003S		1.01	V-Band	V-Band	Internal	N		
Turbine Kits Standard Rotation	PN				A/R	Inlet	Outlet	Wastegate	Divided
Internal Wastegate	740902-0094		0.83	V-Band	V-Band	Internal	N		
	740902-0095		1.01	V-Band	V-Band	Internal	N		
Supercore	PN								
Standard Rotation	880693-5001S								
Reverse Rotation	880694-5001S								
Turbine Kits Standard Rotation	PN				A/R	Inlet	Outlet	Wastegate	Divided
Free Float	740902-0092		1.06	T4	V-Band	External	Y		
	740902-0090		0.83	T3	V-Band	External	N		
	740902-0091		1.01	T3	V-Band	External	N		
	740902-0086		0.61	V-Band	V-Band	External	N		
	740902-0087		0.83	V-Band	V-Band	External	N		
	740902-0088		1.01	V-Band	V-Band	External	N		
	740902-0089		1.21	V-Band	V-Band	External	N		
Turbine Kits Reverse Rotation	PN				A/R	Inlet	Outlet	Wastegate	Divided
Free Float	740902-0100		0.83	T3	V-Band	External	N		
	740902-0101		1.01	T3	V-Band	External	N		
	740902-0096		0.61	V-Band	V-Band	External	N		
	740902-0097		0.83	V-Band	V-Band	External	N		
	740902-0098		1.01	V-Band	V-Band	External	N		
	740902-0099		1.21	V-Band	V-Band	External	N		

Garrett G30-770

Horsepower: 475 - 770
Displacement: 2.0L - 3.5L

Garrett
ADVANCING MOTION

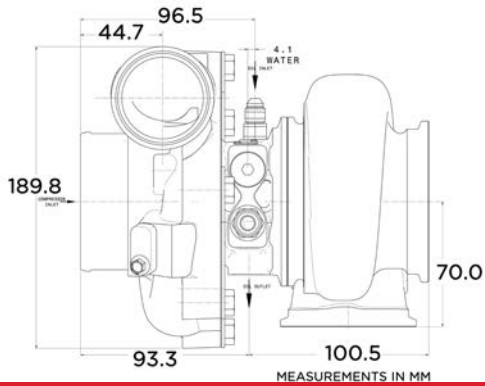

REVERSE ROTATION

COMPRESSOR MAP

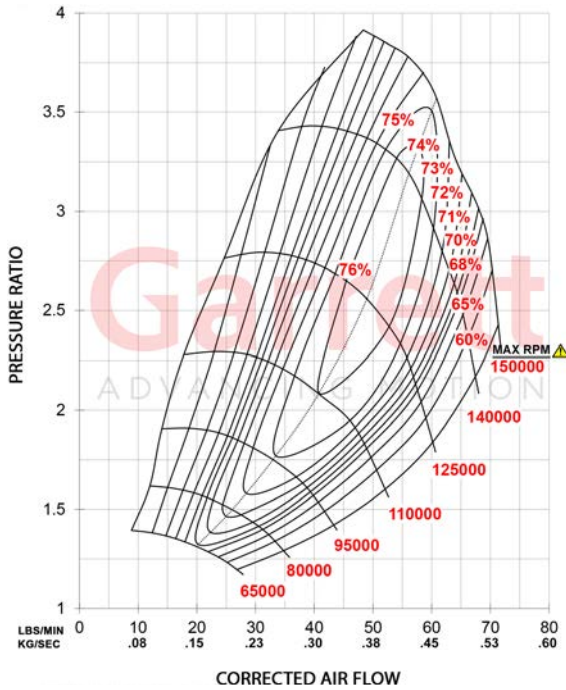

FEATURES:

- ◆ G-SERIES COMPRESSOR AERODYNAMICS FOR MAXIMUM HP
- ◆ G-SERIES TURBINE WHEEL AERO WITH IMPROVED EFFICIENCY
- ◆ STANDARD AND REVERSE ROTATION CONFIGURATIONS
- ◆ TURBINE WHEEL CONSTRUCTED OF MAR-M ALLOY RATED UP TO 1050°C
- ◆ FULLY MACHINED SPEED SENSOR AND PRESSURE PORTS
- ◆ OIL RESTRICTOR AND WATER FITTINGS INCLUDED

EXHAUST FLOW CHART

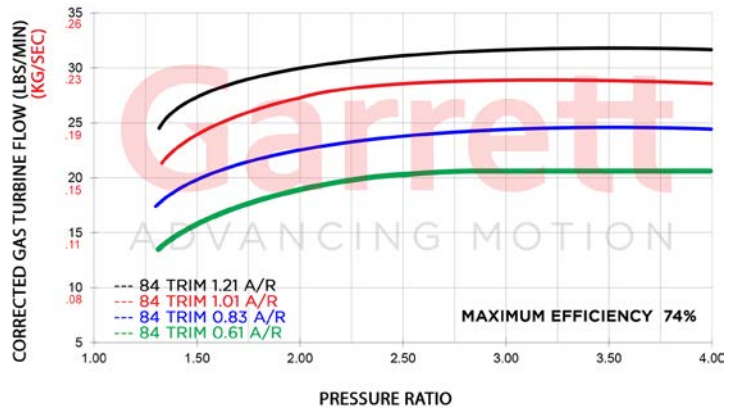

G30-770	Compressor				Inducer	Turbine	
	Inducer	Exducer	Trim	A/R		Exducer	Trim
HP: 475-770 Disp: 2.0L-3.5L	58mm	71mm	65	0.72	60mm	55mm	84
Turbo: Standard Rotation	PN		A/R	Inlet	Outlet	Wastegate	Divided
Assembled and calibrated with 0.5 bar actuator	880704-5005S		0.83	V-Band	V-Band	Internal	N
	880704-5006S		1.01	V-Band	V-Band	Internal	N
Turbine Kits Standard Rotation	PN		A/R	Inlet	Outlet	Wastegate	Divided
Internal Wastegate	740902-0094		0.83	V-Band	V-Band	Internal	N
	740902-0095		1.01	V-Band	V-Band	Internal	N
Supercore	PN						
Standard Rotation	880693-5002S						
Reverse Rotation	880694-5002S						
Turbine Kits Standard Rotation	PN		A/R	Inlet	Outlet	Wastegate	Divided
Free Float	740902-0092		1.06	T4	V-Band	External	Y
	740902-0090		0.83	T3	V-Band	External	N
	740902-0091		1.01	T3	V-Band	External	N
	740902-0086		0.61	V-Band	V-Band	External	N
	740902-0087		0.83	V-Band	V-Band	External	N
	740902-0088		1.01	V-Band	V-Band	External	N
	740902-0089		1.21	V-Band	V-Band	External	N
Turbine Kits Reverse Rotation	PN		A/R	Inlet	Outlet	Wastegate	Divided
Free Float	740902-0100		0.83	T3	V-Band	External	N
	740902-0101		1.01	T3	V-Band	External	N
	740902-0096		0.61	V-Band	V-Band	External	N
	740902-0097		0.83	V-Band	V-Band	External	N
	740902-0098		1.01	V-Band	V-Band	External	N
	740902-0099		1.21	V-Band	V-Band	External	N

Garrett G30-900

Horsepower: 550 - 900
Displacement: 2.0L - 3.5L

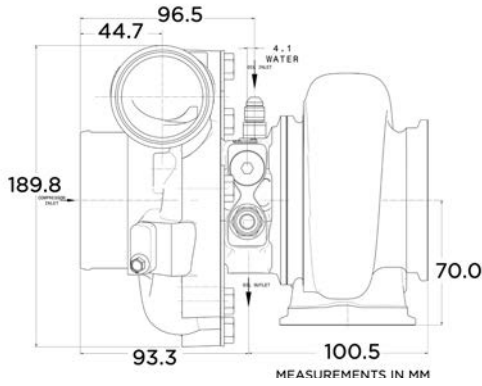

COMPRESSOR MAP

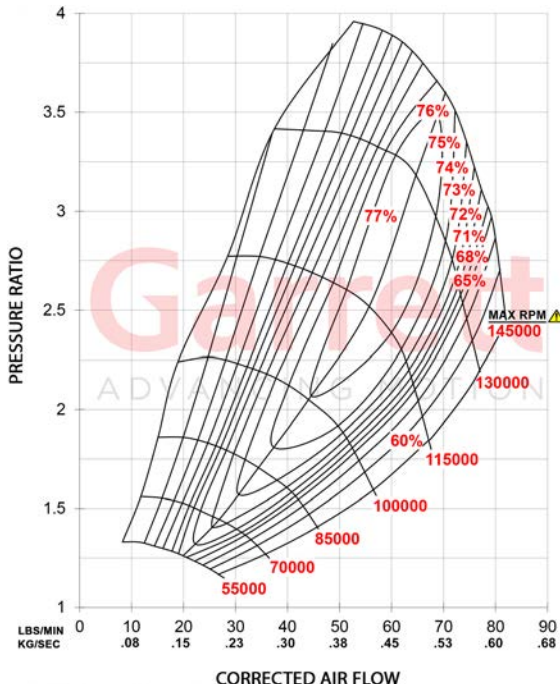

REVERSE ROTATION

FEATURES:

- ◆ G-SERIES COMPRESSOR AERODYNAMICS FOR MAXIMUM HP
- ◆ G-SERIES TURBINE WHEEL AERO WITH IMPROVED EFFICIENCY
- ◆ STANDARD AND REVERSE ROTATION CONFIGURATIONS
- ◆ TURBINE WHEEL CONSTRUCTED OF MAR-M ALLOY RATED UP TO 1050°C
- ◆ FULLY MACHINED SPEED SENSOR AND PRESSURE PORTS
- ◆ OIL RESTRICTOR AND WATER FITTINGS INCLUDED

EXHAUST FLOW CHART

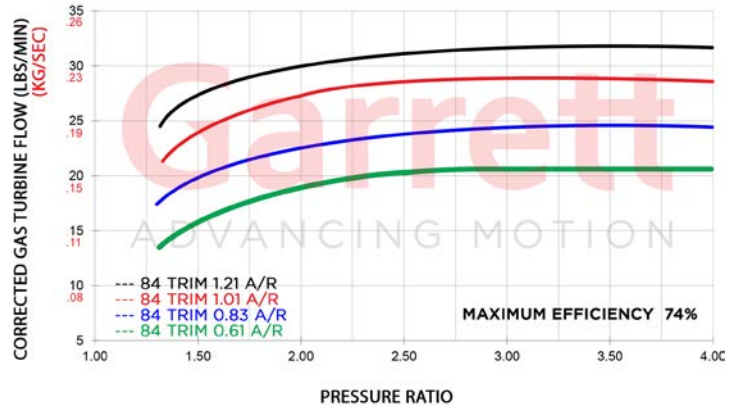

G30-900 HP: 550-900 Disp: 2.0L-3.5L	Compressor				Turbine				
	Inducer 62mm	Exducer 76mm	Trim 65	A/R 0.72	Inducer 60mm	Exducer 55mm	Trim 84		
Turbo: Standard Rotation	PN				A/R	Inlet	Outlet	Wastegate	Divided
Assembled and calibrated with 0.5 bar actuator	880704-5008S		0.83	V-Band	V-Band	V-Band	Internal	N	
	880704-5009S		1.01	V-Band	V-Band	V-Band	Internal	N	
Turbine Kits Standard Rotation	PN				A/R	Inlet	Outlet	Wastegate	Divided
Internal Wastegate	740902-0094		0.83	V-Band	V-Band	V-Band	Internal	N	
	740902-0095		1.01	V-Band	V-Band	V-Band	Internal	N	
Supercore	PN								
Supercore: Standard Rotation	880693-5003S								
Supercore: Reverse Rotation	880694-5003S								
Turbine Kits Standard Rotation	PN				A/R	Inlet	Outlet	Wastegate	Divided
Free Float	740902-0092		1.06	T4	V-Band	V-Band	External	Y	
	740902-0090		0.83	T3	V-Band	V-Band	External	N	
	740902-0091		1.01	T3	V-Band	V-Band	External	N	
	740902-0086		0.61	V-Band	V-Band	V-Band	External	N	
	740902-0087		0.83	V-Band	V-Band	V-Band	External	N	
	740902-0088		1.01	V-Band	V-Band	V-Band	External	N	
	740902-0089		1.21	V-Band	V-Band	V-Band	External	N	
Turbine Kits Reverse Rotation	PN				A/R	Inlet	Outlet	Wastegate	Divided
Free Float	740902-0100		0.83	T3	V-Band	V-Band	External	N	
	740902-0101		1.01	T3	V-Band	V-Band	External	N	
	740902-0096		0.61	V-Band	V-Band	V-Band	External	N	
	740902-0097		0.83	V-Band	V-Band	V-Band	External	N	
	740902-0098		1.01	V-Band	V-Band	V-Band	External	N	
	740902-0099		1.21	V-Band	V-Band	V-Band	External	N	

Garrett G35-900

Horsepower: 550 - 900
Displacement: 2.0L - 5.5L

Garrett
ADVANCING MOTION

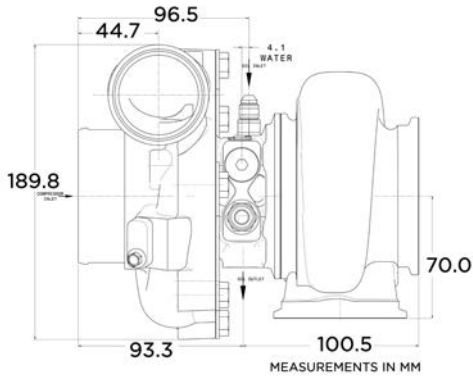

COMPRESSOR MAP

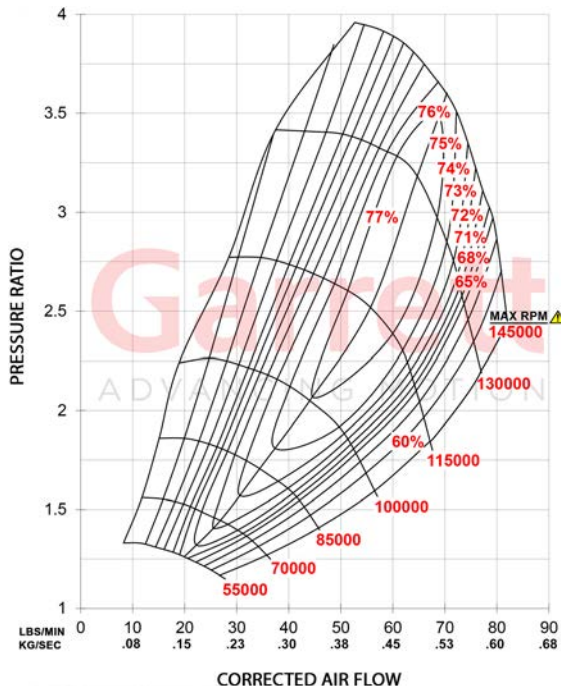

REVERSE ROTATION

FEATURES:

- ◆ G-SERIES COMPRESSOR AERODYNAMICS FOR MAXIMUM HP
- ◆ G-SERIES TURBINE WHEEL AERO WITH IMPROVED EFFICIENCY
- ◆ STANDARD AND REVERSE ROTATION CONFIGURATIONS
- ◆ TURBINE WHEEL CONSTRUCTED OF MAR-M ALLOY RATED UP TO 1050°C
- ◆ FULLY MACHINED SPEED SENSOR AND PRESSURE PORTS
- ◆ OIL RESTRICTOR AND WATER FITTINGS INCLUDED

EXHAUST FLOW CHART

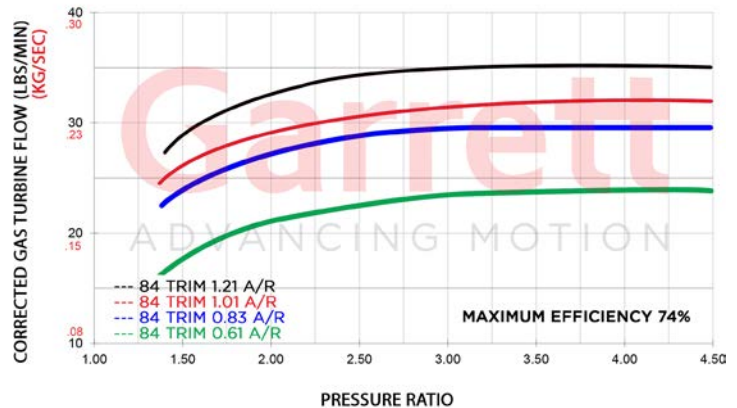

G35-900 HP: 550-900 Disp: 2.0L-5.5L	Compressor				Turbine		
	Inducer	Exducer	Trim	A/R	Inducer	Exducer	Trim
Turbo: Standard Rotation	62mm	76mm	65	0.72	68mm	62mm	84
Assembled and calibrated with 0.5 bar actuator	880707-5002S	PN	A/R	Inlet	Outlet	Wastegate	Divided
Turbine Kits Standard Rotation	880707-5003S	PN	A/R	Inlet	Outlet	Wastegate	Divided
Internal Wastegate	740902-0110	PN	A/R	Inlet	Outlet	Wastegate	Divided
Supercore	740902-0111	PN	A/R	Inlet	Outlet	Wastegate	Divided
Supercore: Standard Rotation	880695-5001S	PN	A/R	Inlet	Outlet	Wastegate	Divided
Supercore: Reverse Rotation	880696-5001S	PN	A/R	Inlet	Outlet	Wastegate	Divided
Turbine Kits Standard Rotation	740902-0108	PN	A/R	Inlet	Outlet	Wastegate	Divided
Free Float	740902-0106	PN	A/R	Inlet	Outlet	Wastegate	Divided
	740902-0107	PN	A/R	Inlet	Outlet	Wastegate	Divided
	740902-0102	PN	A/R	Inlet	Outlet	Wastegate	Divided
	740902-0103	PN	A/R	Inlet	Outlet	Wastegate	Divided
	740902-0104	PN	A/R	Inlet	Outlet	Wastegate	Divided
	740902-0105	PN	A/R	Inlet	Outlet	Wastegate	Divided
Turbine Kits Reverse Rotation	740902-0116	PN	A/R	Inlet	Outlet	Wastegate	Divided
Free Float	740902-0117	PN	A/R	Inlet	Outlet	Wastegate	Divided
	740902-0112	PN	A/R	Inlet	Outlet	Wastegate	Divided
	740902-0113	PN	A/R	Inlet	Outlet	Wastegate	Divided
	740902-0114	PN	A/R	Inlet	Outlet	Wastegate	Divided
	740902-0115	PN	A/R	Inlet	Outlet	Wastegate	Divided

Garrett G35-1050

Horsepower: 700 - 1050
Displacement: 2.0L - 5.5L

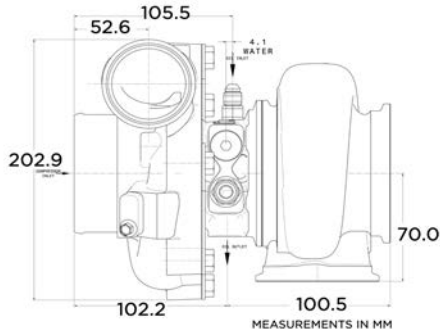

REVERSE ROTATION

COMPRESSOR MAP

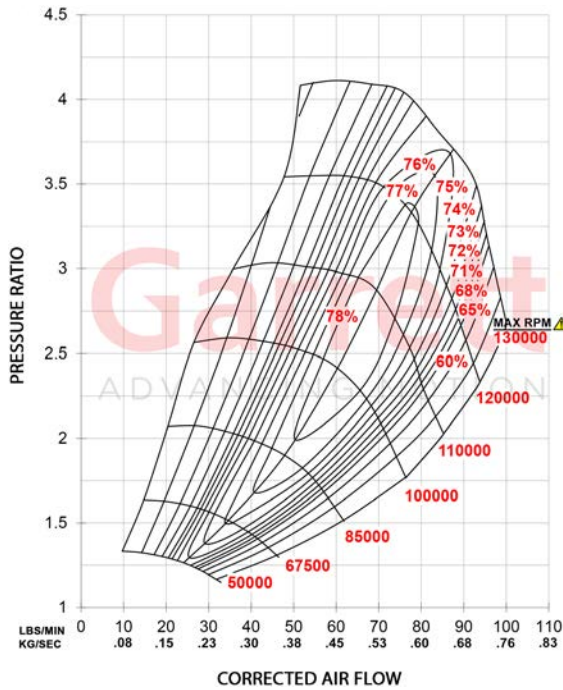

FEATURES:

- ◆ G-SERIES COMPRESSOR AERODYNAMICS FOR MAXIMUM HP
- ◆ G-SERIES TURBINE WHEEL AERO WITH IMPROVED EFFICIENCY
- ◆ STANDARD AND REVERSE ROTATION CONFIGURATIONS
- ◆ TURBINE WHEEL CONSTRUCTED OF MAR-M ALLOY RATED UP TO 1050°C
- ◆ FULLY MACHINED SPEED SENSOR AND PRESSURE PORTS
- ◆ OIL RESTRICTOR AND WATER FITTINGS INCLUDED

EXHAUST FLOW CHART

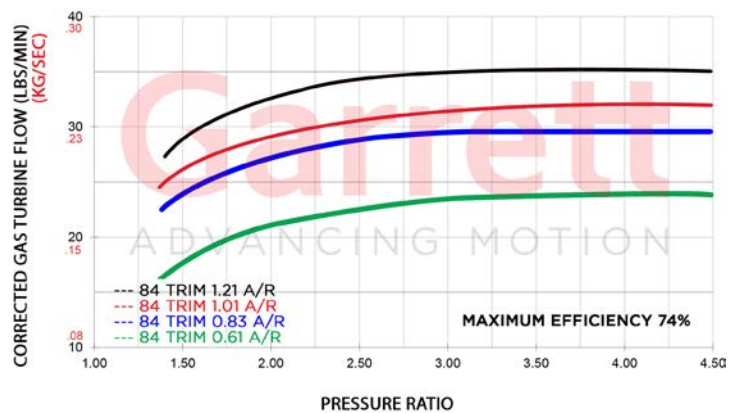

G35-1050	Compressor				Inducer	Turbine		
	Inducer	Exducer	Trim	A/R		Inducer	Exducer	Trim
HP: 700-1050 Disp: 2.0L-5.5L	68mm	84mm	65	0.75	68mm	62mm	84	
Standard Turbo: G35-1050	PN		A/R	Inlet	Outlet	Wastegate	Divided	
Assembled and calibrated with 0.5 bar actuator	880707-5005S		0.83	V-Band	V-Band	Internal	N	
	880707-5006S		1.01	V-Band	V-Band	Internal	N	
Turbine Kits Standard Rotation	PN		A/R	Inlet	Outlet	Wastegate	Divided	
Internal Wastegate	740902-0110		0.83	V-Band	V-Band	Internal	N	
	740902-0111		1.01	V-Band	V-Band	Internal	N	
Supercore	PN							
Supercore: Standard Rotation	880695-5002S							
Supercore: Reverse Rotation	880696-5002S							
Turbine Kits Standard Rotation	PN		A/R	Inlet	Outlet	Wastegate	Divided	
Free Float	740902-0108		1.06	T4	V-Band	External	Y	
	740902-0106		0.83	T3	V-Band	External	N	
	740902-0107		1.01	T3	V-Band	External	N	
	740902-0102		0.61	V-Band	V-Band	External	N	
	740902-0103		0.83	V-Band	V-Band	External	N	
	740902-0104		1.01	V-Band	V-Band	External	N	
	740902-0105		1.21	V-Band	V-Band	External	N	
Turbine Kits Reverse Rotation	PN		A/R	Inlet	Outlet	Wastegate	Divided	
Free Float	740902-0116		0.83	T3	V-Band	External	N	
	740902-0117		1.01	T3	V-Band	External	N	
	740902-0112		0.61	V-Band	V-Band	External	N	
	740902-0113		0.83	V-Band	V-Band	External	N	
	740902-0114		1.01	V-Band	V-Band	External	N	
	740902-0115		1.21	V-Band	V-Band	External	N	

Garrett G40-900

Horsepower: 500 - 900
Displacement: 2.0L - 6.0L

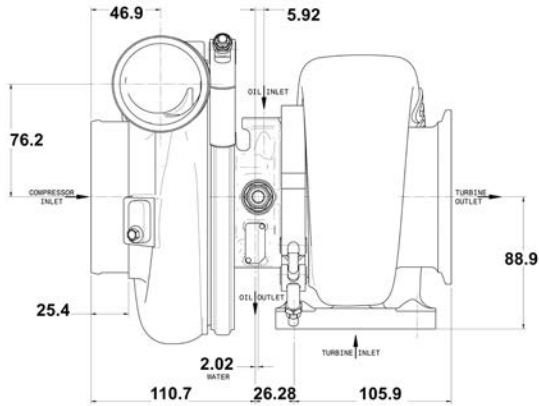

COMPRESSOR MAP

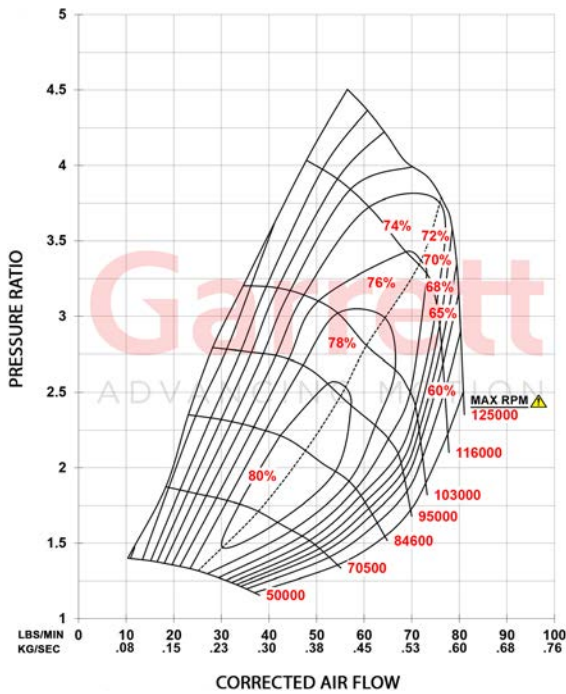

FEATURES:

- ◆ UP TO 32% MORE COMPRESSOR FLOW (COMPARED TO GTX4088R)
- ◆ CERAMIC DUAL BALL BEARING WITH STEEL CAGES
- ◆ UP TO 16% MORE TURBINE FLOW (COMPARED TO GTX4088R)
- ◆ 77MM INCONEL TURBINE WHEEL FLOWS UP TO 43 LBS/MIN
- ◆ LIGHTWEIGHT ALUMINUM BACKPLATE
- ◆ FULLY MACHINED SPEED SENSOR AND PRESSURE PORTS
- ◆ WATER FITTINGS INCLUDED WITH SUPERCORE
- ◆ STAINLESS STEEL V-BAND AND T4 TWIN SCROLL TURBINE HOUSINGS
- ◆ T4 TURBINE HOUSING OUTLET V-BAND DIMENSION (117.4MM | 4.622" OD) IS EQUAL TO EXISTING GTX42, GTX45 AND G42 MODELS

EXHAUST FLOW CHART

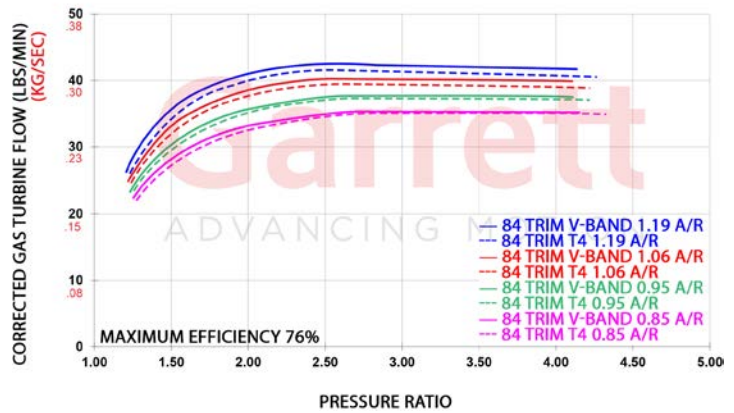

G40-900	Compressor				Turbine								
	HP: 500-900	Disp: 2.0L-6.0L	Inducer 62mm	Exducer 88mm	Trim 51	A/R 0.80	Inducer 77mm	Exducer 70mm	Trim 84				
Supercore		PN											
Standard Rotation		860777-5003S											
Turbine Kits: G40		PN											
Free Float		757707-0027		0.85		V-Band		V-Band		External		N	
		757707-0028		0.95		V-Band		V-Band		External		N	
		757707-0029		1.06		V-Band		V-Band		External		N	
		757707-0030		1.19		V-Band		V-Band		External		N	
		757707-0032		0.85		T4		V-Band		External		Y	
		757707-0033		0.95		T4		V-Band		External		Y	
		757707-0034		1.06		T4		V-Band		External		Y	
		757707-0035		1.19		T4		V-Band		External		Y	

Garrett G40-1150

Horsepower: 500 - 1150
Displacement: 2.0L - 6.0L

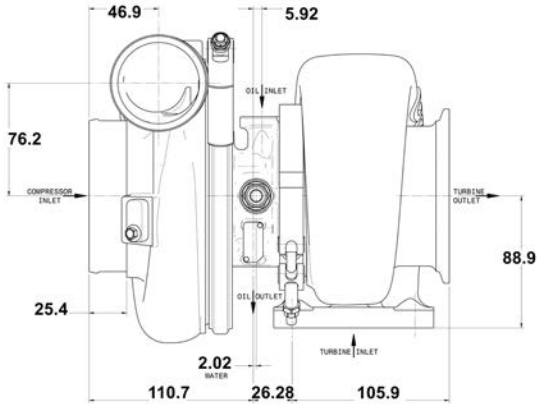

COMPRESSOR MAP

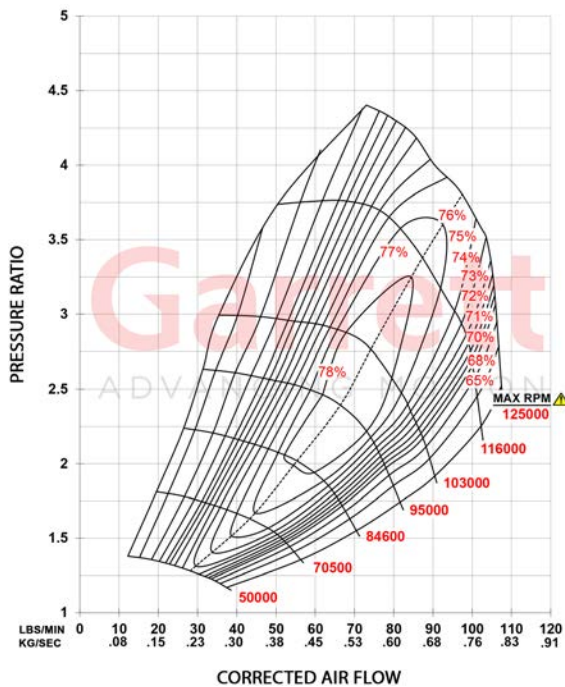

FEATURES:

- ◆ UP TO 32% MORE COMPRESSOR FLOW (COMPARED TO GTX4088R)
- ◆ CERAMIC DUAL BALL BEARING WITH STEEL CAGES
- ◆ UP TO 16% MORE TURBINE FLOW (COMPARED TO GTX4088R)
- ◆ 77MM INCONEL TURBINE WHEEL FLOWS UP TO 43 LBS/MIN
- ◆ LIGHTWEIGHT ALUMINUM BACKPLATE
- ◆ FULLY MACHINED SPEED SENSOR AND PRESSURE PORTS
- ◆ WATER FITTINGS INCLUDED WITH SUPERCORE
- ◆ STAINLESS STEEL V-BAND AND T4 TWIN SCROLL TURBINE HOUSINGS
- ◆ T4 TURBINE HOUSING OUTLET V-BAND DIMENSION (117.4MM | 4.622" OD) IS EQUAL TO EXISTING GTX42, GTX45 AND G42 MODELS

EXHAUST FLOW CHART

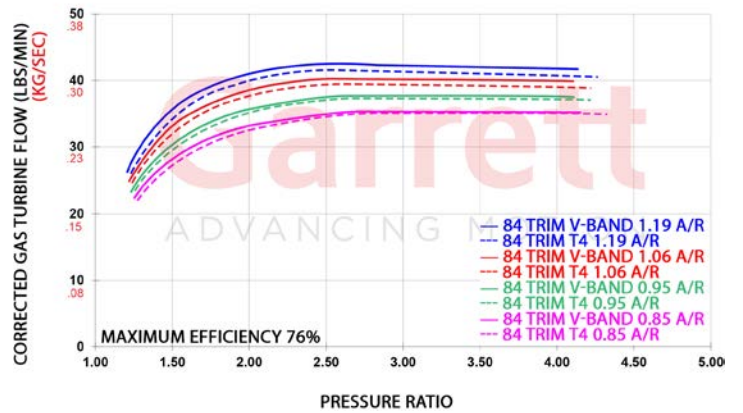

G40-1150		Compressor				Turbine		
		Inducer	Exducer	Trim	A/R	Inducer	Exducer	Trim
HP: 500-1150	Disp: 2.0L-6.0L	71mm	88mm	65	0.80	77mm	70mm	84
Supercore		PN						
Standard Rotation		860777-5002S						
Turbine Kits: G40		PN		A/R	Inlet	Outlet	Wastegate	Divided
Free Float		757707-0027		0.85	V-Band	V-Band	External	N
		757707-0028		0.95	V-Band	V-Band	External	N
		757707-0029		1.06	V-Band	V-Band	External	N
		757707-0030		1.19	V-Band	V-Band	External	N
		757707-0032		0.85	T4	V-Band	External	Y
		757707-0033		0.95	T4	V-Band	External	Y
		757707-0034		1.06	T4	V-Band	External	Y
		757707-0035		1.19	T4	V-Band	External	Y

Garrett G42-1200 Compact

Horsepower: 475 - 1200
Displacement: 2.0L - 7.0L

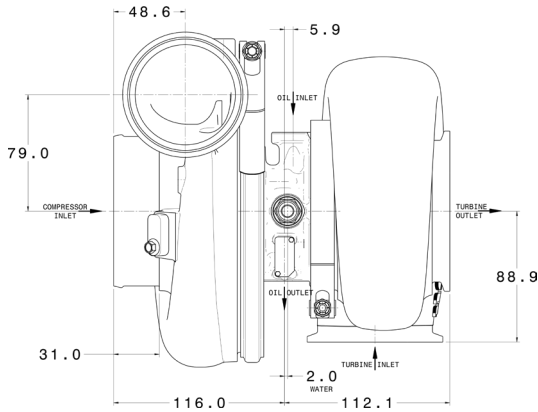

COMPRESSOR MAP

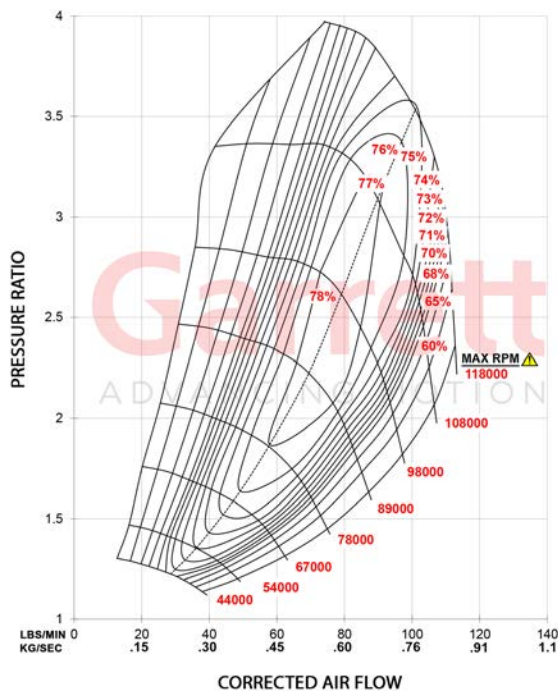

FEATURES:

- ◆ GARRETT G-SERIES COMPRESSOR AERODYNAMICS FOR MAXIMUM HP
- ◆ FULLY MACHINED SPEED SENSOR AND PRESSURE PORTS
- ◆ NEW TURBINE WHEEL AERO FOR INCREASED EFFICIENCY AND FLOW
- ◆ STAINLESS STEEL V-BAND AND T4 TWIN SCROLL TURBINE HOUSINGS
- ◆ WATER FITTINGS INCLUDED

EXHAUST FLOW CHART

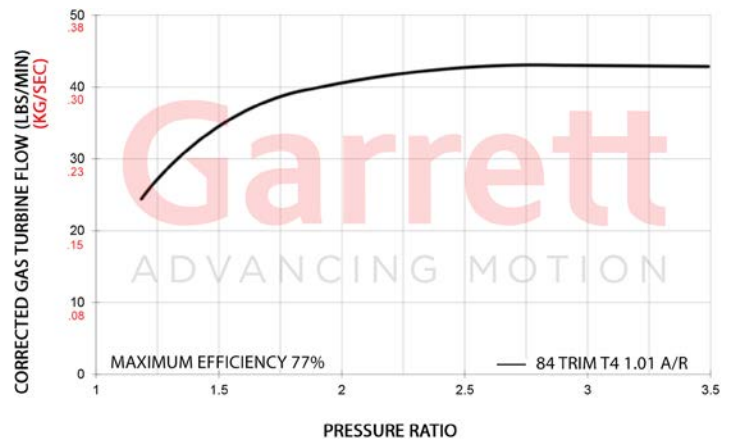

G42-1200 Compact	Compressor				Turbine				
	HP: 475-1200	Disp: 2.0L-7.0L	Inducer	Exducer	Trim	A/R	Inducer	Exducer	Trim
Supercore			73mm	91mm	65	0.90	82mm	75mm	84
Compact Comp Housing	PN 860778-5002S								
Turbine Kits: G42			PN		A/R	Inlet	Outlet	Wastegate	Divided
Free Float			757707-0011		1.01	V-Band	V-Band	External	N
			757707-0012		1.15	V-Band	V-Band	External	N
			757707-0013		1.28	V-Band	V-Band	External	N
			757707-0014		1.01	T4	V-Band	External	Y
			757707-0015		1.15	T4	V-Band	External	Y
			757707-0016		1.28	T4	V-Band	External	Y

Garrett G42-1200

Horsepower: 475 - 1200
Displacement: 2.0L - 7.0L

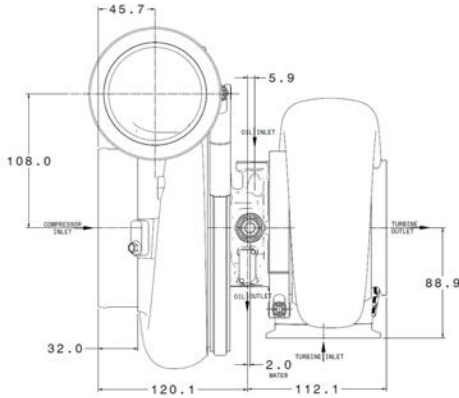

COMPRESSOR MAP

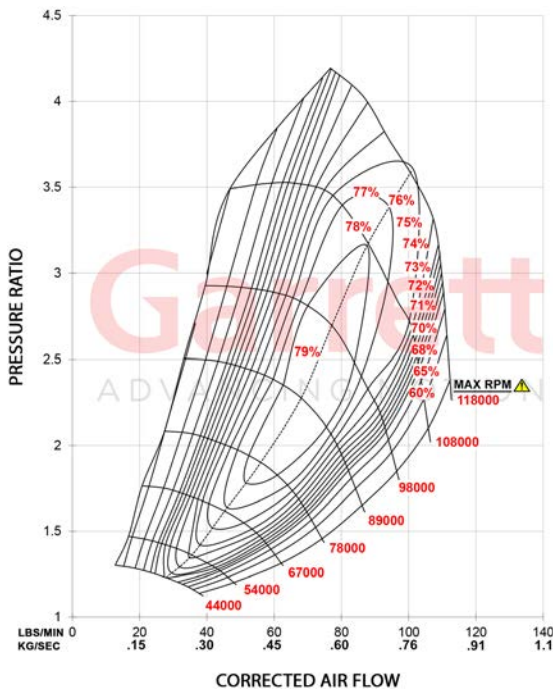

FEATURES:

- ◆ GARRETT G-SERIES COMPRESSOR AERODYNAMICS FOR MAXIMUM HP
- ◆ FULLY MACHINED SPEED SENSOR AND PRESSURE PORTS
- ◆ NEW TURBINE WHEEL AERO FOR INCREASED EFFICIENCY AND FLOW
- ◆ STAINLESS STEEL V-BAND AND T4 TWIN SCROLL TURBINE HOUSINGS
- ◆ WATER FITTINGS INCLUDED

EXHAUST FLOW CHART

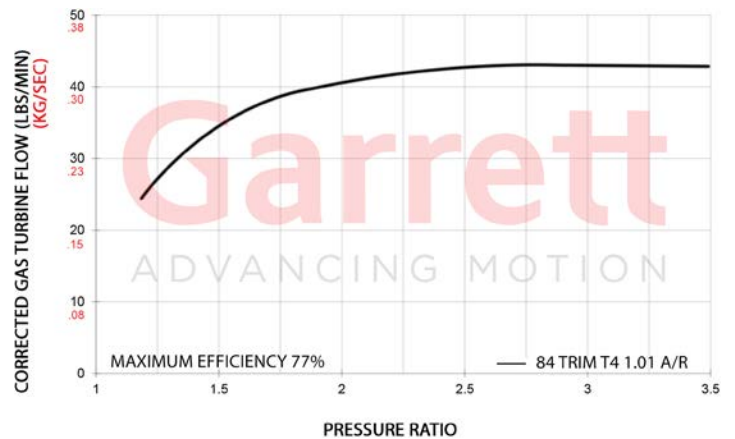

G42-1200 HP: 475-1200 Disp: 2.0L-7.0L	Compressor				Turbine				
	Inducer	Exducer	Trim	A/R	Inducer	Exducer	Trim		
Supercore	73mm	91mm	65	0.85	82mm	75mm	84		
Full-Size Comp Housing	860778-5004S								
Turbine Kits: G42	PN				A/R	Inlet	Outlet	Wastegate	Divided
Free Float	757707-0011		1.01	V-Band	V-Band	External	N		
	757707-0012		1.15	V-Band	V-Band	External	N		
	757707-0013		1.28	V-Band	V-Band	External	N		
	757707-0014		1.01	T4	V-Band	External	Y		
	757707-0015		1.15	T4	V-Band	External	Y		
	757707-0016		1.28	T4	V-Band	External	Y		

Garrett G42-1450

Horsepower: 525 - 1450
Displacement: 2.0L - 8.0L

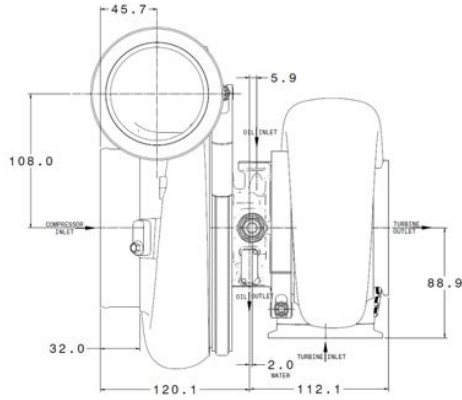

COMPRESSOR MAP

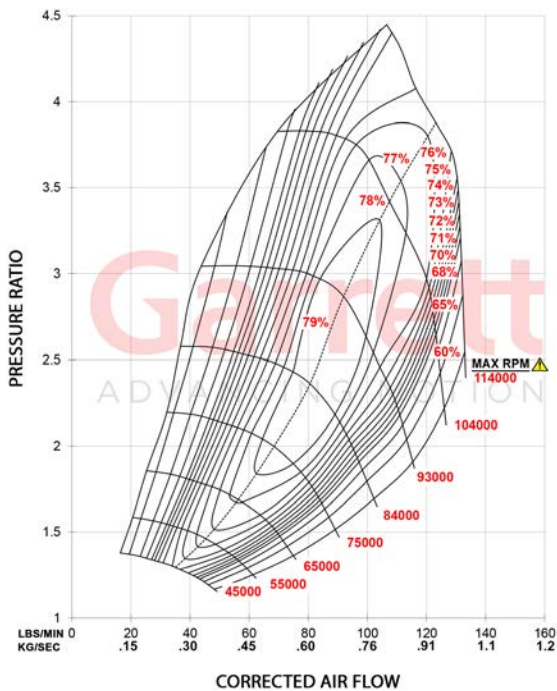

FEATURES:

- ◆ GARRETT G-SERIES COMPRESSOR AERODYNAMICS FOR MAXIMUM HP
- ◆ FULLY MACHINED SPEED SENSOR AND PRESSURE PORTS
- ◆ NEW TURBINE WHEEL AERO FOR INCREASED EFFICIENCY AND FLOW
- ◆ STAINLESS STEEL V-BAND AND T4 TWIN SCROLL TURBINE HOUSINGS
- ◆ WATER FITTINGS INCLUDED

EXHAUST FLOW CHART

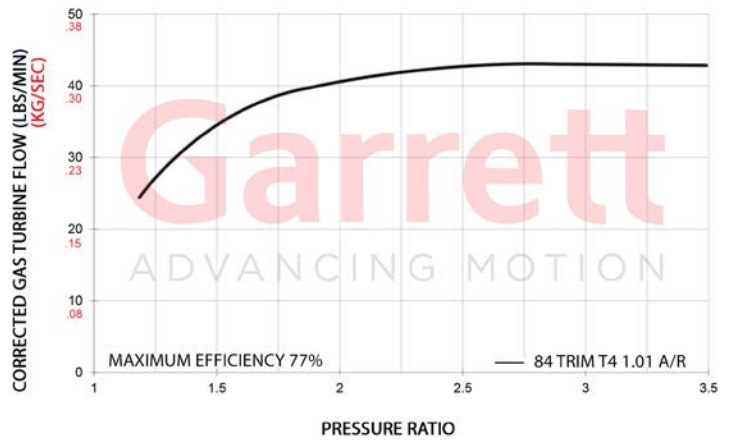

G42-1450	Compressor				Turbine				
	HP: 525-1450	Disp: 2.0L-8.0L	Inducer 79mm	Exducer 98mm	Trim 65	A/R 0.85	Inducer 82mm	Exducer 75mm	Trim 84
Supercore	PN								
Standard Rotation	860778-5006S								
Turbine Kits: G42	PN		A/R	Inlet	Outlet	Wastegate	Divided		
Free Float	757707-0011		1.01	V-Band	V-Band	External	N		
	757707-0012		1.15	V-Band	V-Band	External	N		
	757707-0013		1.28	V-Band	V-Band	External	N		
	757707-0014		1.01	T4	V-Band	External	Y		
	757707-0015		1.15	T4	V-Band	External	Y		
	757707-0016		1.28	T4	V-Band	External	Y		

Garrett G45-1125

Horsepower: 600 - 1125
Displacement: 2.0L - 8.0L

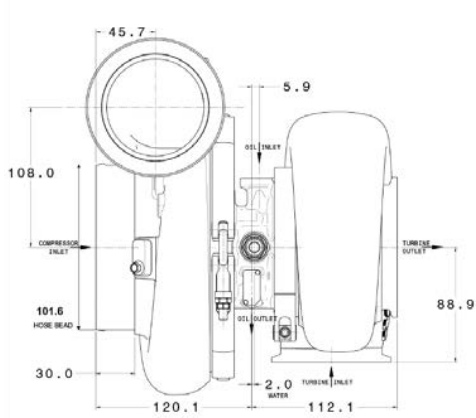

COMPRESSOR MAP

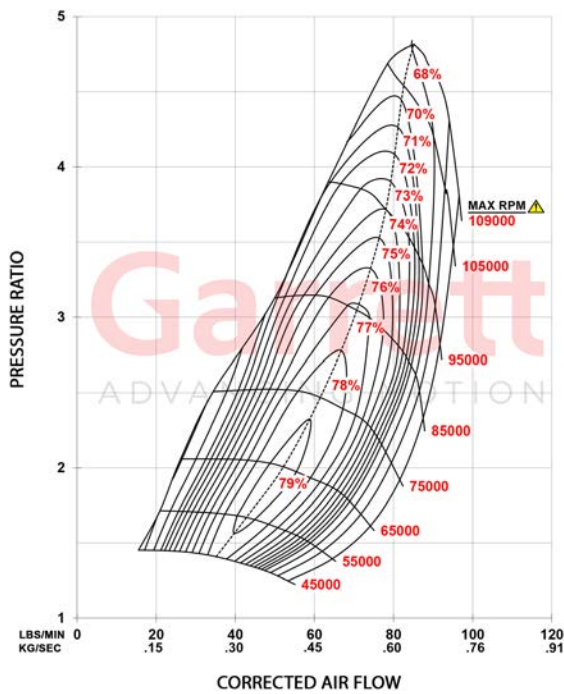

FEATURES:

- ◆ COMPRESSOR AERO INCREASES FLOW UP TO 10% (COMPARED TO GTX4502R 67MM)
- ◆ 67MM COMPRESSOR INDUCER | 102MM COMPRESSOR EXDUCER
- ◆ 10MM CERAMIC DUAL BALL BEARING WITH STEEL CAGES
- ◆ G-SERIES TURBINE AERO INCREASES FLOW 14% (COMPARED TO GTX45R)
- ◆ 89MM INCONEL TURBINE WHEEL INDUCER FLOWS UP TO 56 LBS/MIN
- ◆ LIGHTWEIGHT ALUMINUM BACKPLATE
- ◆ STAINLESS STEEL V-BAND AND T4 TWIN SCROLL TURBINE HOUSINGS

EXHAUST FLOW CHART

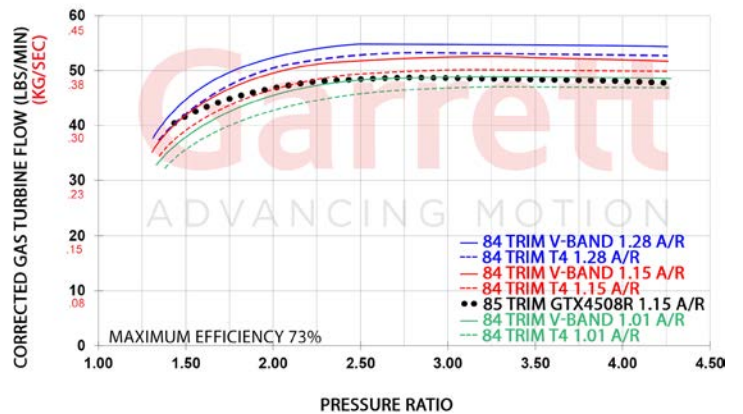

G45-1125	Compressor				Turbine		
	Inducer	Exducer	Trim	A/R	Inducer	Exducer	Trim
HP: 600-1125 Disp: 2.0L-8.0L	67mm	102mm	44	0.85	89mm	82mm	84
Supercore	PN						
Standard Rotation	888169-5003S						
Turbine Kits: G45	PN		A/R	Inlet	Outlet	Wastegate	Divided
Free Float	757707-0019		1.01	V-Band	V-Band	External	N
	757707-0020		1.15	V-Band	V-Band	External	N
	757707-0021		1.28	V-Band	V-Band	External	N
	757707-0022		1.44	V-Band	V-Band	External	N
	757707-0023		1.01	T4	V-Band	External	Y
	757707-0024		1.15	T4	V-Band	External	Y
	757707-0025		1.28	T4	V-Band	External	Y
	757707-0026		1.44	T4	V-Band	External	Y

Garrett G45-1350

Horsepower: 650 - 1350
Displacement: 2.0L - 8.0L

Garrett
ADVANCING MOTION

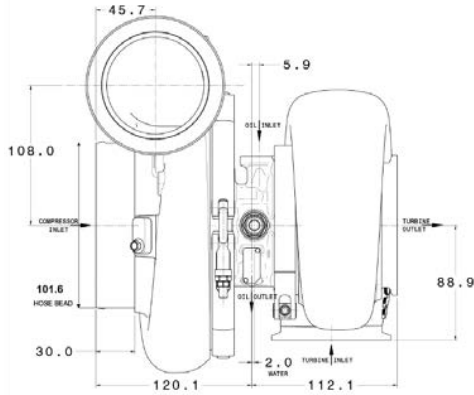

COMPRESSOR MAP

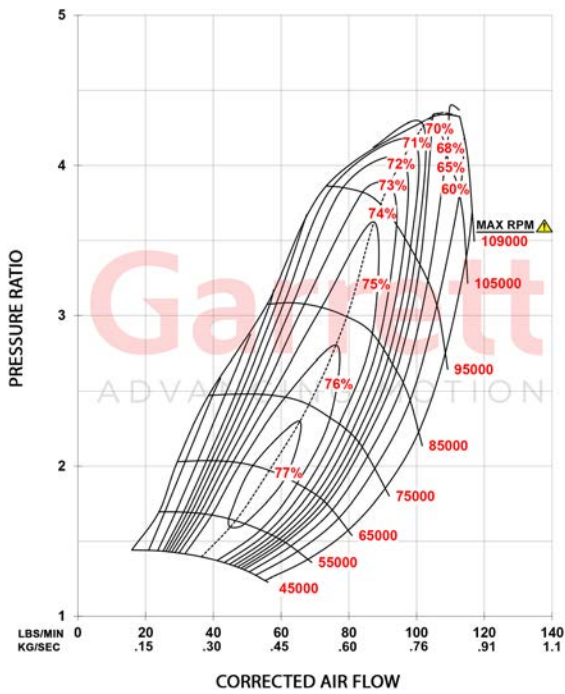

FEATURES:

- ◆ COMPRESSOR AERO INCREASES FLOW UP TO 15% (COMPARED TO GTX4502R 72MM)
- ◆ 72MM COMPRESSOR INDUCER | 102MM COMPRESSOR EXDUCER
- ◆ 10MM CERAMIC DUAL BALL BEARING WITH STEEL CAGES
- ◆ G-SERIES TURBINE AERO INCREASES FLOW 14% (COMPARED TO GTX45R)
- ◆ 89MM INCONEL TURBINE WHEEL INDUCER FLOWS UP TO 56 LBS/MIN
- ◆ LIGHTWEIGHT ALUMINUM BACKPLATE
- ◆ STAINLESS STEEL V-BAND AND T4 TWIN SCROLL TURBINE HOUSINGS

EXHAUST FLOW CHART

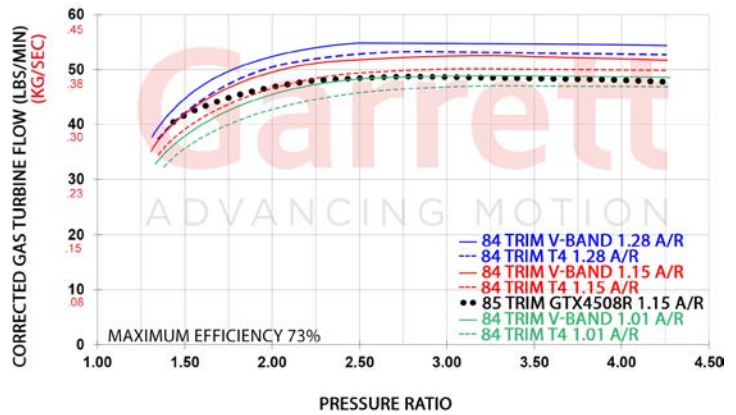

G45-1350		Compressor				Turbine		
		Inducer	Exducer	Trim	A/R	Inducer	Exducer	Trim
HP: 650-1350	Disp: 2.0L-8.0L	72mm	102mm	51	0.85	89mm	82mm	84
Supercore		PN						
Standard Rotation		888169-5004S						
Turbine Kits: G45		PN		A/R	Inlet	Outlet	Wastegate	Divided
Free Float		757707-0019		1.01	V-Band	V-Band	External	N
		757707-0020		1.15	V-Band	V-Band	External	N
		757707-0021		1.28	V-Band	V-Band	External	N
		757707-0022		1.44	V-Band	V-Band	External	N
		757707-0023		1.01	T4	V-Band	External	Y
		757707-0024		1.15	T4	V-Band	External	Y
		757707-0025		1.28	T4	V-Band	External	Y
		757707-0026		1.44	T4	V-Band	External	Y

Garrett G45-1500

Horsepower: 750 - 1500
Displacement: 2.0L - 8.0L

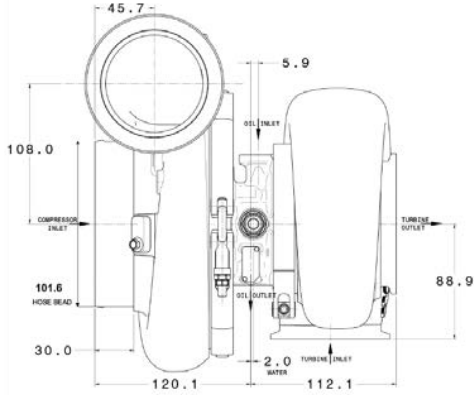

COMPRESSOR MAP

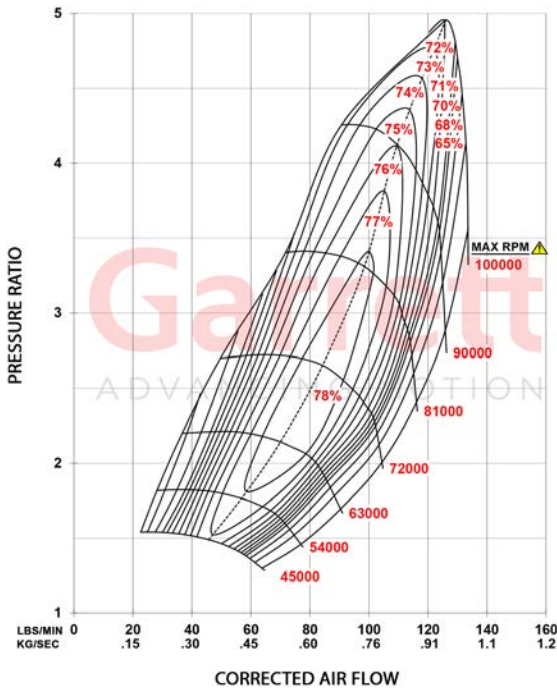

FEATURES:

- ◆ COMPRESSOR AERO INCREASES FLOW UP TO 18% (COMPARED TO GTX4508R 76MM)
- ◆ 76MM COMPRESSOR INDUCER | 102MM COMPRESSOR EXDUCER
- ◆ 10MM CERAMIC DUAL BALL BEARING WITH STEEL CAGES
- ◆ G-SERIES TURBINE AERO INCREASES FLOW 14% (COMPARED TO GTX45R)
- ◆ 89MM INCONEL TURBINE WHEEL INDUCER FLOWS UP TO 56 LBS/MIN
- ◆ LIGHTWEIGHT ALUMINUM BACKPLATE
- ◆ STAINLESS STEEL V-BAND AND T4 TWIN SCROLL TURBINE HOUSINGS

EXHAUST FLOW CHART

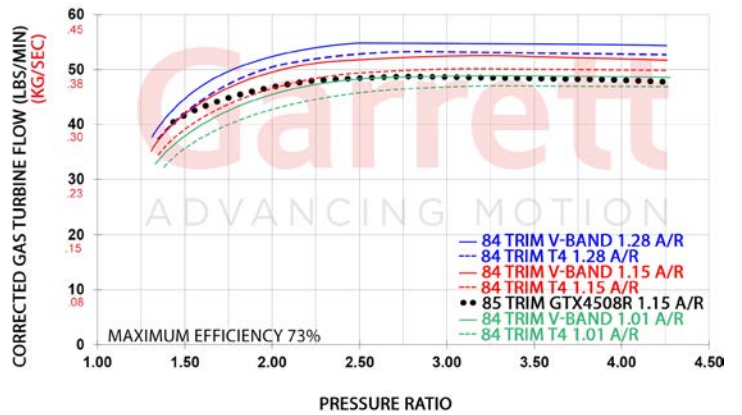

G45-1500	Compressor				Turbine		
	Inducer	Exducer	Trim	A/R	Inducer	Exducer	Trim
HP: 750-1500 Disp: 2.0L-8.0L	76mm	109mm	49	0.85	89mm	82mm	84
Supercore	PN						
Standard Rotation	888169-5005S						
Turbine Kits: G45	PN		A/R	Inlet	Outlet	Wastegate	Divided
Free Float	757707-0019		1.01	V-Band	V-Band	External	N
	757707-0020		1.15	V-Band	V-Band	External	N
	757707-0021		1.28	V-Band	V-Band	External	N
	757707-0022		1.44	V-Band	V-Band	External	N
	757707-0023		1.01	T4	V-Band	External	Y
	757707-0024		1.15	T4	V-Band	External	Y
	757707-0025		1.28	T4	V-Band	External	Y
	757707-0026		1.44	T4	V-Band	External	Y

Garrett G45-1475

Horsepower: 750 - 1475
Displacement: 2.0L - 8.0L

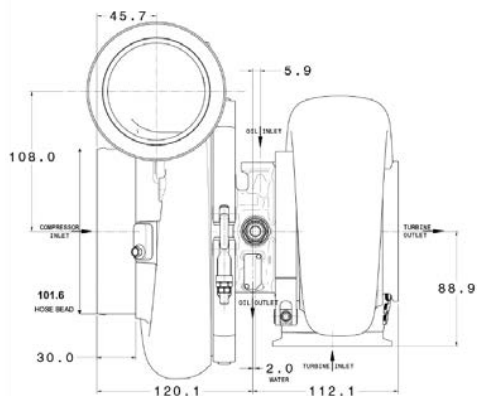

COMPRESSOR MAP

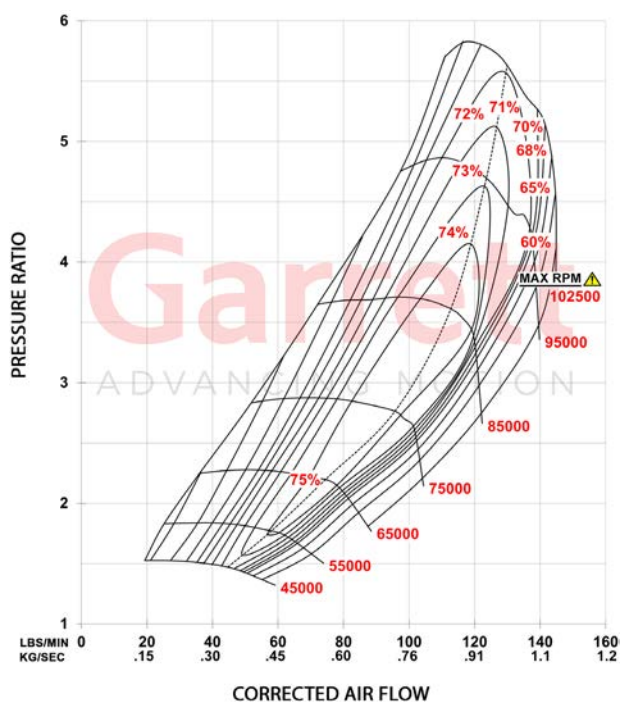

FEATURES:

- ◆ 79MM COMPRESSOR INDUCER | 98MM COMPRESSOR EXDUCER
- ◆ LARGER 65 TRIM COMPRESSOR WHEEL
- ◆ 10MM CERAMIC DUAL BALL BEARING WITH STEEL CAGES
- ◆ G-SERIES TURBINE AERO INCREASES FLOW 14% (COMPARED TO GTX45R)
- ◆ 89MM INCONEL TURBINE WHEEL INDUCER FLOWS UP TO 56 LBS/MIN
- ◆ LIGHTWEIGHT ALUMINUM BACKPLATE
- ◆ STAINLESS STEEL V-BAND AND T4 TWIN SCROLL TURBINE HOUSINGS

EXHAUST FLOW CHART

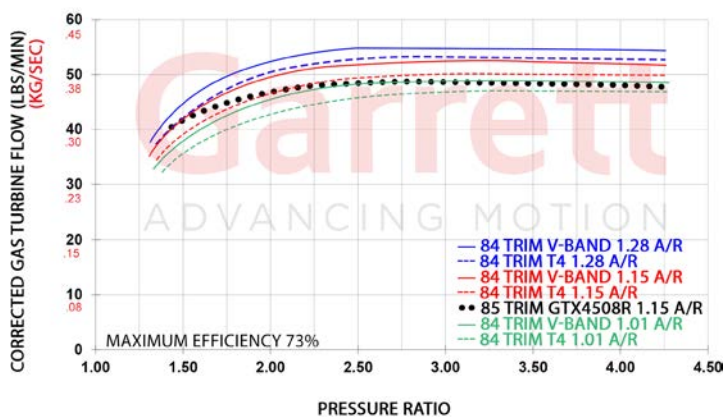

G45-1475 HP: 750-1475 Disp: 2.0L-8.0L	Compressor				Turbine		
	Inducer	Exducer	Trim	A/R	Inducer	Exducer	Trim
	79mm	98mm	65	0.85	89mm	82mm	84
Supercore	PN						
Standard Rotation	888169-5007S						
Turbine Kits:	PN		A/R	Inlet	Outlet	Wastegate	Divided
Free Float	757707-0019		1.01	V-Band	V-Band	External	N
	757707-0020		1.15	V-Band	V-Band	External	N
	757707-0021		1.28	V-Band	V-Band	External	N
	757707-0022		1.44	V-Band	V-Band	External	N
	757707-0023		1.01	T4	V-Band	External	Y
	757707-0024		1.15	T4	V-Band	External	Y
	757707-0025		1.28	T4	V-Band	External	Y
	757707-0026		1.44	T4	V-Band	External	Y

Garrett G45-1600

Horsepower: 750 - 1600
 Displacement: 2.0L - 8.0L

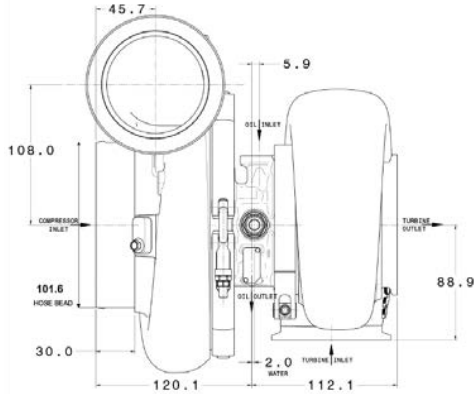

COMPRESSOR MAP

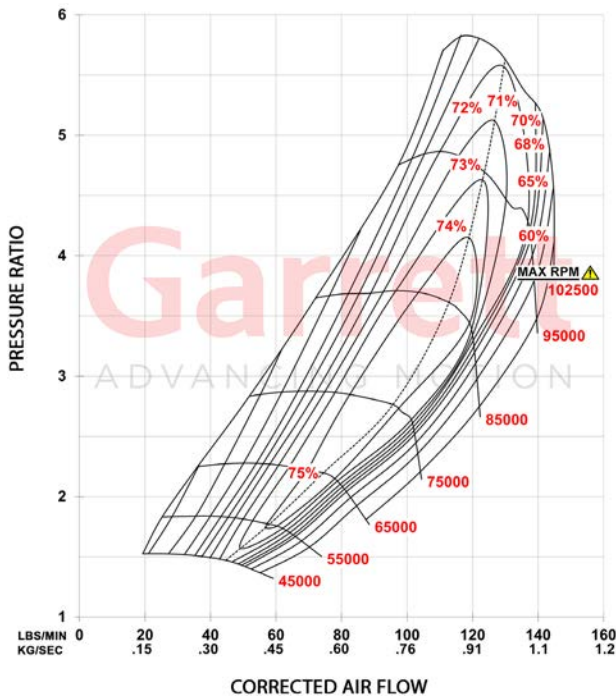

FEATURES:

- ◆ COMPRESSOR AERO INCREASES FLOW UP TO 16% (COMPARED TO GTX4508R 76MM)
- ◆ 80MM COMPRESSOR INDUCER | 102MM COMPRESSOR EXDUCER
- ◆ 10MM CERAMIC DUAL BALL BEARING WITH STEEL CAGES
- ◆ G-SERIES TURBINE AERO INCREASES FLOW 14% (COMPARED TO GTX45R)
- ◆ 89MM INCONEL TURBINE WHEEL INDUCER FLOWS UP TO 56 LBS/MIN
- ◆ LIGHTWEIGHT ALUMINUM BACKPLATE
- ◆ STAINLESS STEEL V-BAND AND T4 TWIN SCROLL TURBINE HOUSINGS

EXHAUST FLOW CHART

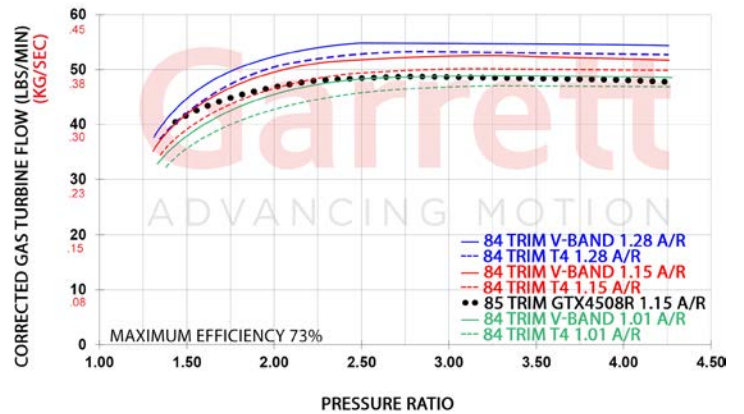

G45-1600		Compressor				Inducer	Turbine	Trim
		Inducer	Exducer	Trim	A/R			
HP: 750-1600	Disp: 2.0L-8.0L	80mm	109mm	54	0.85	89mm	82mm	84
Supercore		PN						
Standard Rotation		888169-5006S						
Turbine Kits: G45		PN		A/R	Inlet	Outlet	Wastegate	Divided
Free Float		757707-0019		1.01	V-Band	V-Band	External	N
		757707-0020		1.15	V-Band	V-Band	External	N
		757707-0021		1.28	V-Band	V-Band	External	N
		757707-0022		1.44	V-Band	V-Band	External	N
		757707-0023		1.01	T4	V-Band	External	Y
		757707-0024		1.15	T4	V-Band	External	Y
		757707-0025		1.28	T4	V-Band	External	Y
		757707-0026		1.44	T4	V-Band	External	Y

Garrett G47

Horsepower: 825 - 1850
Displacement: 2.5L - 10.0L

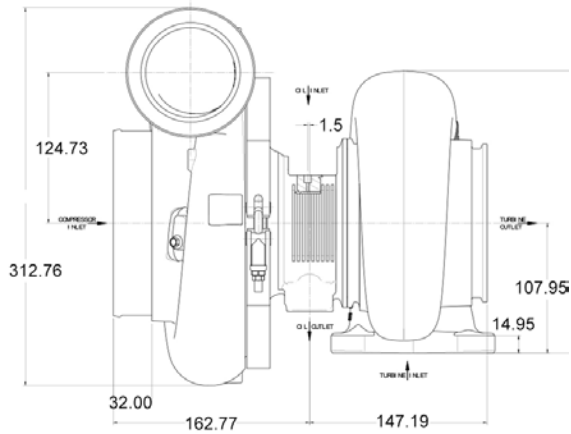

COMPRESSOR MAP

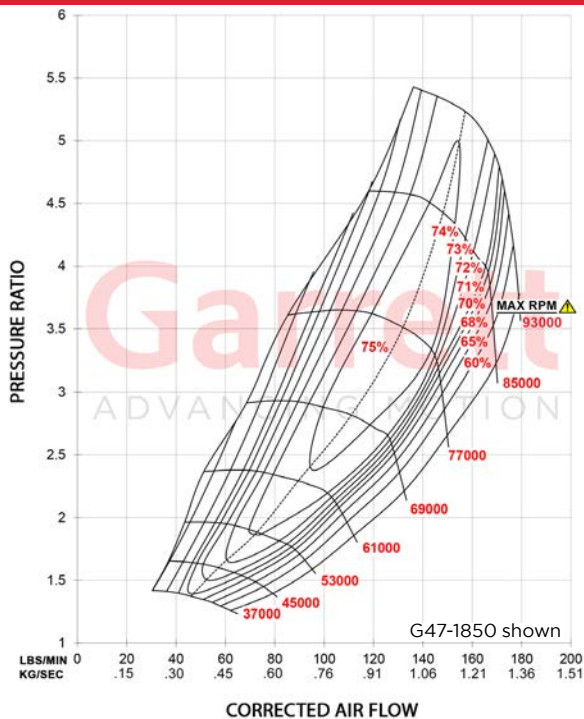

FEATURES:

- ◆ OUTLINE INTERCHANGEABLE WITH GTX GEN II TURBOS
- ◆ 76MM | 80MM COMP IND | 109MM COMP EXD
- ◆ 80MM | 88MM COMP IND | 120 COMP EXD
- ◆ HIGH FLOW, HIGH EFFICIENCY GTX GEN II COMP AERO
- ◆ G-SERIES TURBINE WHEEL AERO INCREASES PERFORMANCE COMPARED TO GTX47 GEN II: • FLOW: UP TO 20% MORE • SPOOL: UP TO +9% (ESTIMATED BY FLOW, EFFICIENCY, AND INERTIA)
- ◆ ONE-PIECE LIGHTWEIGHT ALUMINUM CENTER HSG/BACKPLATE

EXHAUST FLOW CHART

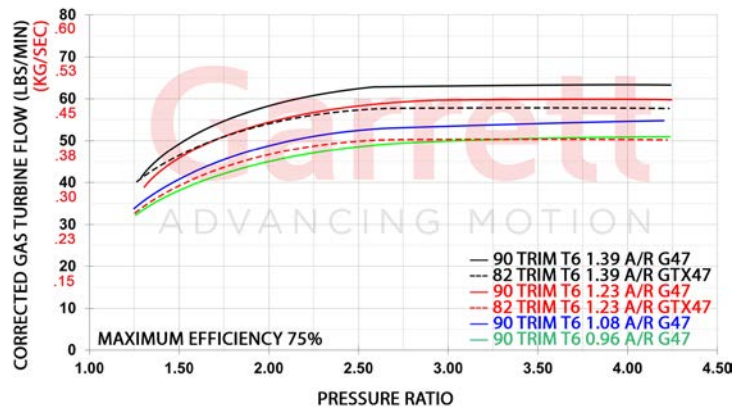

G-Series G47		Compressor			Turbine		
HP: 825-1850	Disp: 2.5L-10.0L	Inducer	Exducer	A/R	Inducer	Exducer	Trim
Supercore	PN						
G47-1550	880547-5023S	76mm	109mm	0.88	93mm	88mm	90
G47-1650	880547-5024S	80mm	109mm	0.88	93mm	88mm	90
G47-1650	880547-5025S	80mm	120mm	0.88	93mm	88mm	90
G47-1850	880547-5026S	88mm	120mm	0.88	93mm	88mm	90
Turbine Kits: G47		PN	A/R	Inlet	Outlet	Wastegate	Divided
Free Float	761208-0075	0.96	T6	V-Band	External	N	
	761208-0076	1.08	T6	V-Band	External	N	
	761208-0077	1.23	T6	V-Band	External	N	
	761208-0078	1.39	T6	V-Band	External	N	

COMPRESSOR MAPS:



G47-1550 76mm



G47-1650
80/109mm



G47-1650
80/120mm



G47-1850 88mm

Garrett G50

Horsepower: 875 - 1900
Displacement: 2.5L - 11.0L

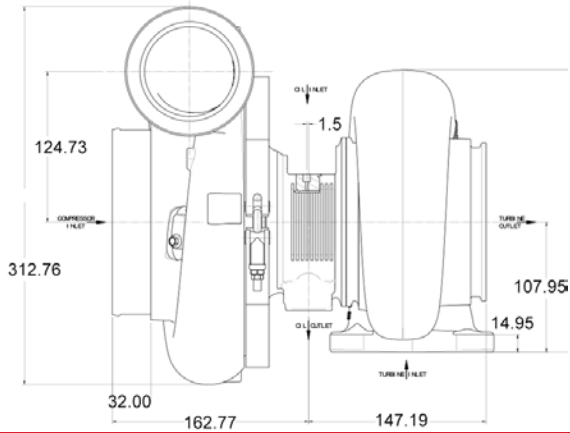

COMPRESSOR MAP

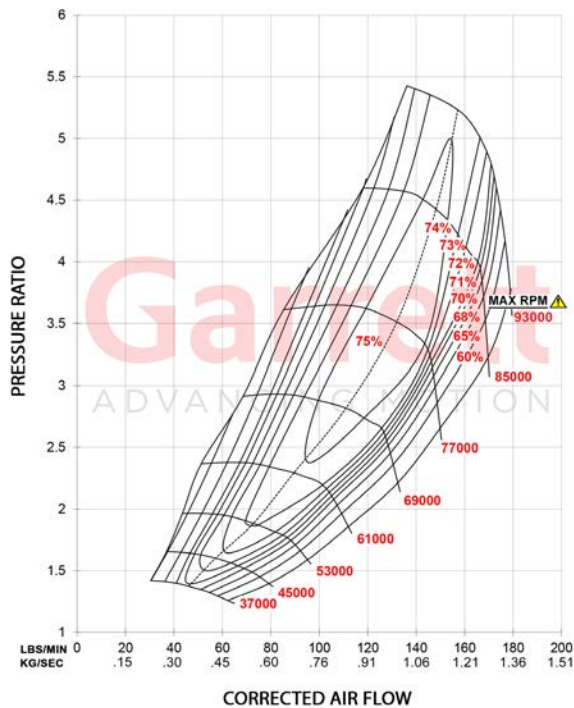

FEATURES:

- ◆ OUTLINE INTERCHANGEABLE WITH GTX GEN II TURBOS
- ◆ 80MM COMP IND | 109MM COMP EXD
- ◆ 88MM COMP IND | 120MM COMP EXD
- ◆ HIGH FLOW, HIGH EFFICIENCY GTX GEN II COMP AERO
- ◆ G-SERIES TURBINE WHEEL AERO INCREASES PERFORMANCE COMPARED TO GTX50 GEN II: • FLOW: UP TO 23% MORE • SPOOL: UP TO +12% (ESTIMATED BY FLOW, EFFICIENCY, AND INERTIA)
- ◆ ONE-PIECE LIGHTWEIGHT ALUMINUM CENTER HSG/BACKPLATE

EXHAUST FLOW CHART

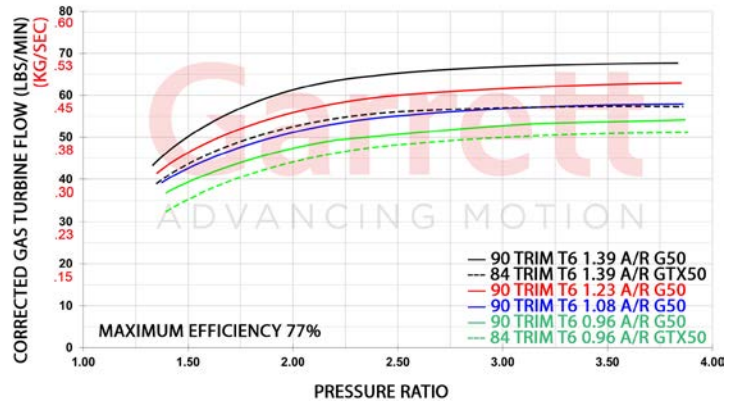

G-Series G50		Compressor			Turbine		
HP: 875-1900	Disp: 2.5L-10.0L	Inducer	Exducer	A/R	Inducer	Exducer	Trim
Supercore	PN						
G50-1700	880547-5027S	80mm	109mm	0.88	99mm	94mm	90
G50-1900	880547-5028S	88mm	120mm	0.88	99mm	94mm	90
Turbine Kits: G50		PN	A/R	Inlet	Outlet	Wastegate	Divided
Free Float	761208-0079		0.96	T6	V-Band	External	N
	761208-0080		1.08	T6	V-Band	External	N
	761208-0081		1.23	T6	V-Band	External	N
	761208-0082		1.39	T6	V-Band	External	N

COMPRESSOR MAPS:



G47-1650
80/109mm



G47-1850 88mm

Garrett G55

Horsepower: 1000 - 2900
Displacement: 3.0L - 12.0L

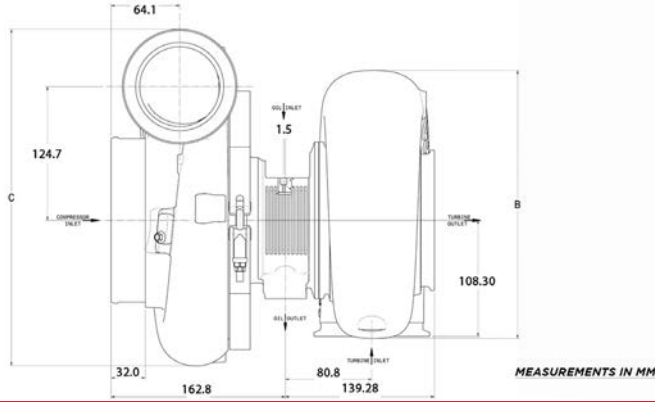

COMPRESSOR MAP

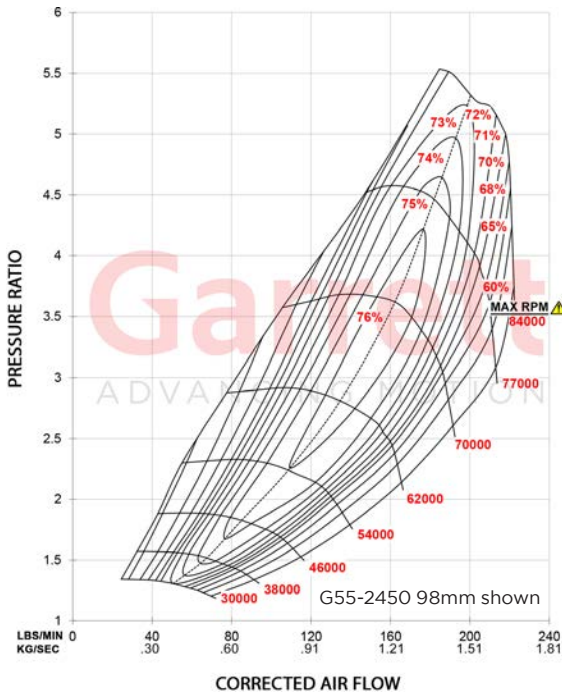

FEATURES:

- ◆ 85MM, 88MM, 91MM, 94MM, 98MM, 102MM, 106MM COMPRESSOR SIZES
- ◆ GTX GEN II COMPRESSOR AERODYNAMICS
- ◆ 106MM TURBINE EXDUCER (+4MM COMPARED TO GTX55)
- ◆ 15% MORE TURBINE FLOW (COMPARED TO GTX)
- ◆ 6% INCREASE IN SPOOL-UP PERFORMANCE
- ◆ STAINLESS STEEL TURBINE HOUSINGS IN T6 AND V-BAND INLET
- ◆ ONE-PIECE ALUMINUM CENTER HOUSING (28% LIGHTER)
- ◆ 16MM CERAMIC DUAL BALL BEARING WITH STEEL CAGES
- ◆ OUTLINE INTERCHANGEABLE WITH GTX GEN II TURBOS

EXHAUST FLOW CHART

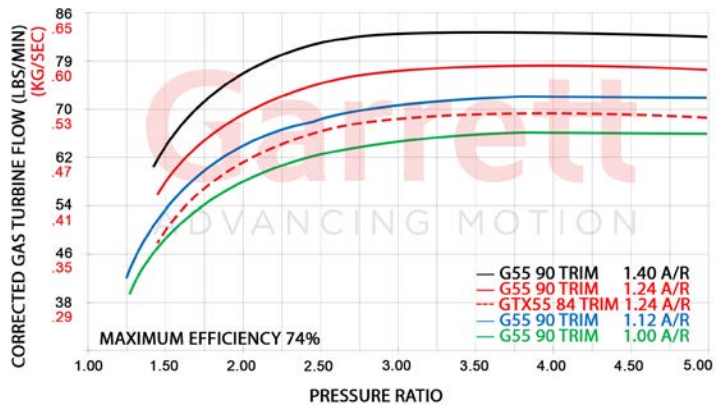

G Series G55		Compressor			Turbine		
HP: 1000-2900	Disp: 3.0L-12.0L	Inducer	Exducer	A/R	Inducer	Exducer	Trim
Supercore		PN					
G55-1850	880547-5001S	85mm	133mm	0.88	112mm	106mm	90
G55-1950	880547-5002S	88mm	133mm	0.88	112mm	106mm	90
G55-2100	880547-5003S	91mm	133mm	0.96	112mm	106mm	90
G55-2250	880547-5004S	94mm	133mm	0.96	112mm	106mm	90
G55-2450	880547-5005S	98mm	133mm	0.96	112mm	106mm	90
G55-2650	880547-5021S	102mm	144mm	0.96	112mm	106mm	90
G55-2900	880547-5022S	106mm	144mm	0.96	112mm	106mm	90
Turbine Kits: G55		PN			Inlet	Outlet	Wastegate
Free Float		761208-0069	1.24	V-Band	V-Band	External	N
		761208-0070	1.40	V-Band	V-Band	External	N
		761208-0071	1.00	T6	V-Band	External	N
		761208-0072	1.12	T6	V-Band	External	N
		761208-0073	1.24	T6	V-Band	External	N
		761208-0074	1.40	T6	V-Band	External	N

COMPRESSOR MAPS:



G55-1850 85mm



G55-1950 88mm



G55-2100 91mm



G55-2250 94mm



G55-2650 102mm



G55-2900 106mm

Garrett G57

Horsepower: 1400 - 3000
Displacement: 3.0L - 12.0L

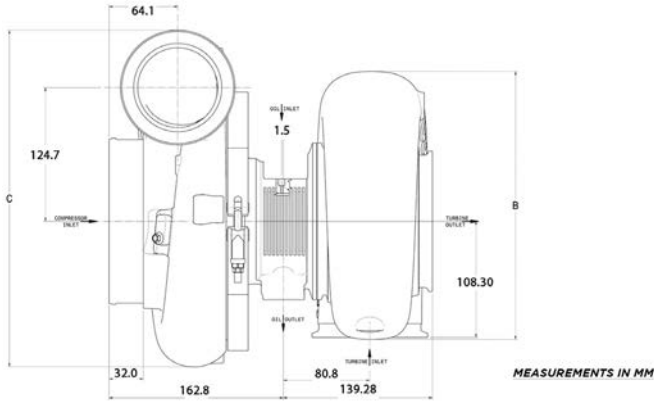

COMPRESSOR MAP

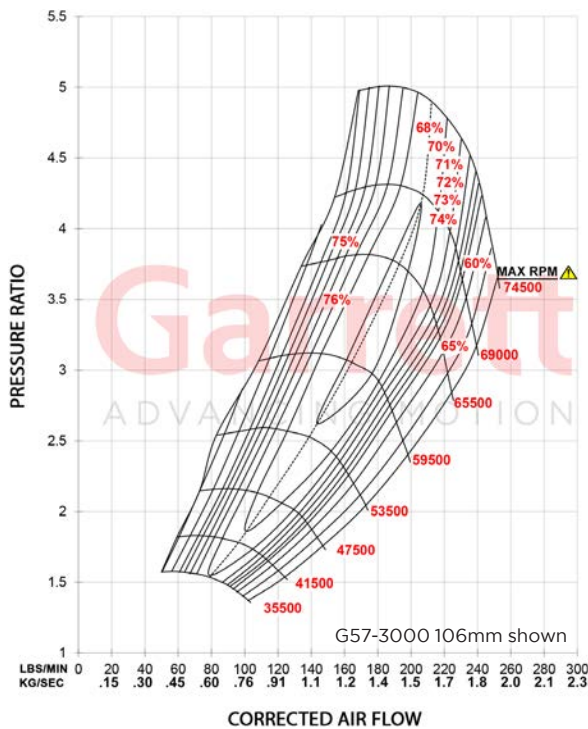

FEATURES:

- ◆ 88MM, 94MM, 98MM, 102MM, 106MM COMPRESSOR OPTIONS
- ◆ 118MM INDUCER TURBINE WHEEL
- ◆ 28% MORE TURBINE FLOW (COMPARED TO GTX) SEE GRAPH BELOW
- ◆ STAINLESS STEEL TURBINE HOUSINGS
- ◆ ONE-PIECE ALUMINUM CENTER HOUSING
- ◆ 16MM CERAMIC DUAL BALL BEARING WITH STEEL CAGES
- ◆ OUTLINE INTERCHANGEABLE WITH GTX GEN II TURBOS
- ◆ STAINLESS STEEL TURBINE KIT SOLD INDIVIDUALLY. 1.09 A/R, 1.25 A/R, 1.41 A/R

EXHAUST FLOW CHART

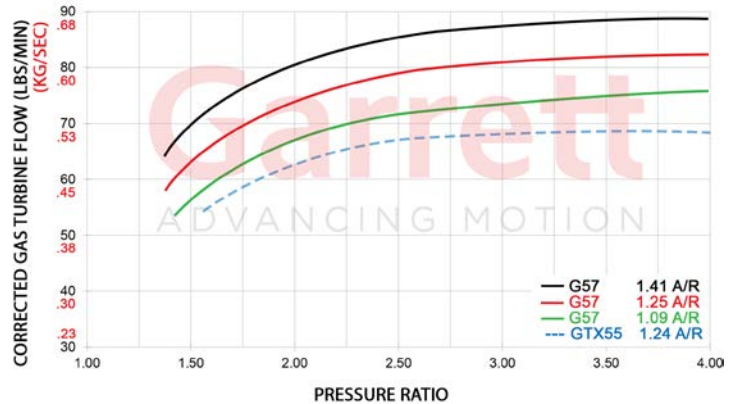

G Series G57		Compressor			Turbine		
HP: 1400-3000	Disp: 3.0L-12.0L	Inducer	Exducer	A/R	Inducer	Exducer	Trim
Supercore PN							
G57-2000	880547-5031S	88mm	133mm	0.88	118mm	112mm	90
G57-2350	880547-5032S	94mm	133mm	0.96	118mm	112mm	90
G57-2550	880547-5033S	98mm	133mm	0.96	118mm	112mm	90
G57-2750	880547-5029S	102mm	144mm	0.96	118mm	112mm	90
G57-3000	880547-5030S	106mm	144mm	0.96	118mm	112mm	90
Turbine Kits: G57		PN	A/R	Inlet	Outlet	Wastegate	Divided
Free Float		761208-0083	1.09	V-Band	V-Band	External	N
		761208-0084	1.25	V-Band	V-Band	External	N
		761208-0085	1.41	V-Band	V-Band	External	N

COMPRESSOR MAPS:



G57-2000 88mm



G57-2350 94mm



G57-2550 98mm



G57-2750 102mm

G-XRACE

When Xtreme Power Meets Xtreme Performance

Winners aren't born – they are built. Reputations are forged through skill, speed and consistency. Racers push their skills, their cars, and their turbos to extreme limits. When the stakes are high, only the best turbo will take you to the finish line. Garrett G-XRace is built for those who know that winning comes from being the quickest, pass after pass, race after race.



GXRACE



Garrett GXR40-64

Horsepower: 500-1150
Displacement: 2.0L - 6.0L

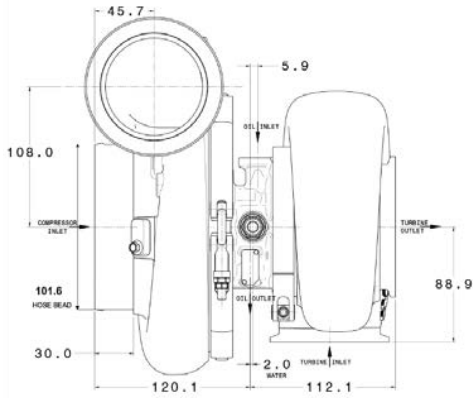

COMPRESSOR MAP

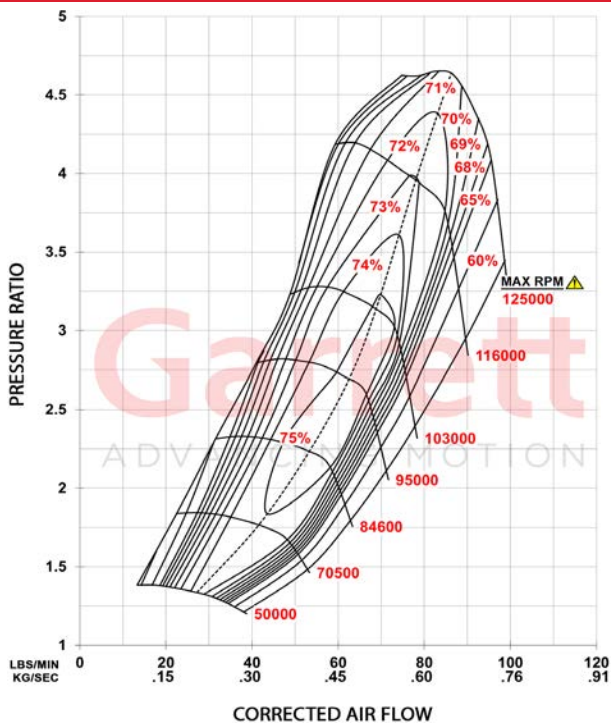

FEATURES:

- ◆ XBOOST TECHNOLOGY INCREASES POWER AND PERFORMANCE
- ◆ +23% COMPRESSOR FLOW (GXR40-64 COMPARED TO G40-900)
- ◆ ENHANCED PRESSURE RATIO CAPABILITY AND HIGHER BOOST PRESSURE
- ◆ INCREASED EFFICIENCY AT HIGH FLOW RATES
- ◆ LOWER INTAKE TEMPERATURE
- ◆ LIGHTWEIGHT ALUMINUM BACKPLATE
- ◆ FULLY MACHINED FLANGE-STYLE SPEED SENSOR PORT FOR EASY SENSOR INSTALLATION AND MONITORING TURBO SPEED
- ◆ UTILIZES THE SAME TWIN-SCROLL T4 AND V-BAND TURBINE HOUSINGS AS G-SERIES TO ENABLE AN EASY UPGRADE

EXHAUST FLOW CHART

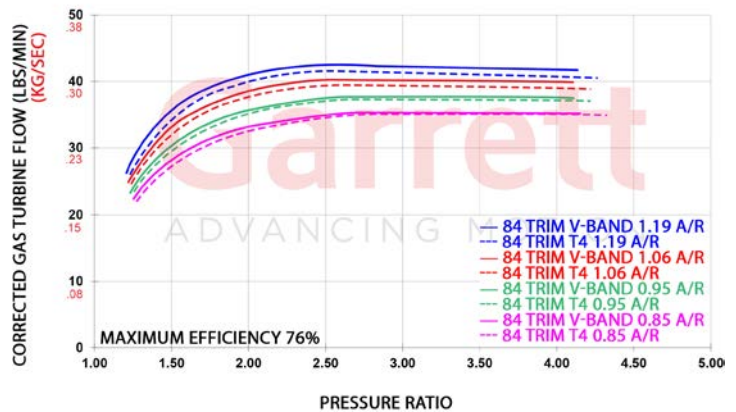

GXR40-64 HP: 500-1150 Disp: 2.0L-6.0L	Compressor				Turbine		
	Inducer	Exducer	Trim	A/R	Inducer	Exducer	Trim
	64.9mm	88mm	53	0.85	77mm	70mm	84
Supercore	PN						
Standard Rotation	934173-50055						
Turbine Kits:	PN	A/R	Inlet	Outlet	Wastegate	Divided	
Free Float	757707-0027	0.85	V-Band	V-Band	External	N	
	757707-0028	0.95	V-Band	V-Band	External	N	
	757707-0029	1.06	V-Band	V-Band	External	N	
	757707-0030	1.19	V-Band	V-Band	External	N	
	757707-0032	0.85	T4	V-Band	External	Y	
	757707-0033	0.95	T4	V-Band	External	Y	
	757707-0034	1.06	T4	V-Band	External	Y	
	757707-0035	1.19	T4	V-Band	External	Y	

Approved for use in drag racing classes with compressor wheel inducer limits 64.9. Please verify class rules before purchasing.

Garrett GXR42-68

Horsepower: 650 - 1400

Displacement: 2.0L - 7.0L

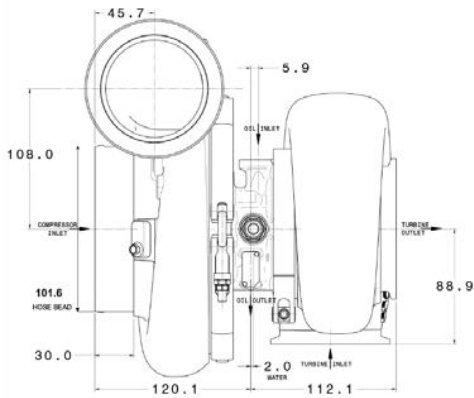

COMPRESSOR MAP

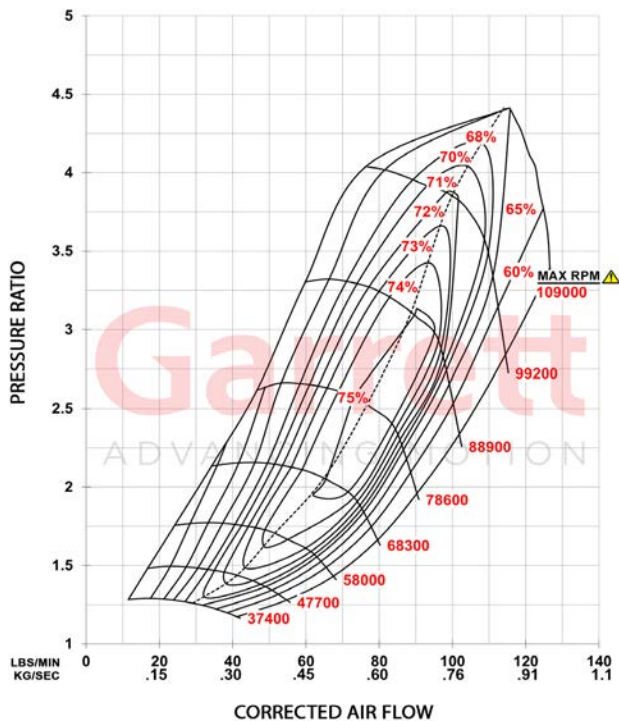

FEATURES:

- ◆ XBOOST TECHNOLOGY INCREASES POWER AND PERFORMANCE
- ◆ ENHANCED PRESSURE RATIO CAPABILITY AND HIGHER BOOST PRESSURE
- ◆ INCREASED EFFICIENCY AT HIGH FLOW RATES
- ◆ LOWER INTAKE TEMPERATURE
- ◆ LIGHTWEIGHT ALUMINUM BACKPLATE
- ◆ TWIN-SCROLL T4 AND V-BAND TURBINE INLET FLANGES AVAILABLE FOR RACERS WITH DIFFERENT ENGINES AND MANIFOLD DESIGNS

EXHAUST FLOW CHART

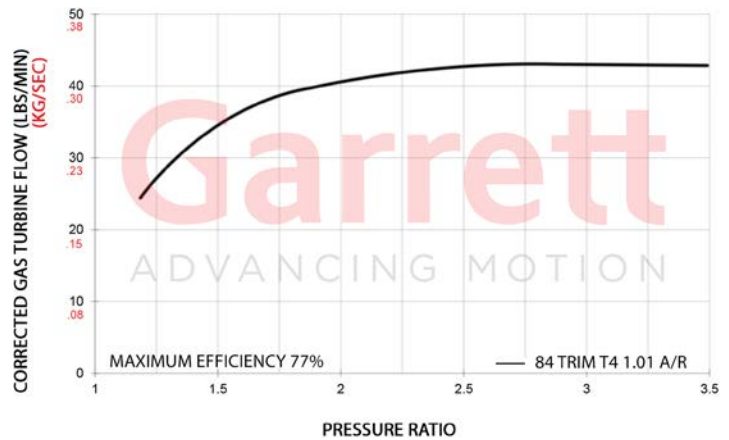

GXR42-68	Compressor				Turbine				
	HP: 650-1400	Disp: 2.0L-7.0L	Inducer	Exducer	Trim	A/R	Inducer	Exducer	Trim
			68.9mm	102mm	45	0.85	82mm	75mm	84
Supercore	PN								
Standard Rotation	934173-5001S								
Turbine Kits:			PN	A/R	Inlet	Outlet	Wastegate	Divided	
Free Float			757707-0011	1.01	V-Band	V-Band	External	N	
			757707-0012	1.15	V-Band	V-Band	External	N	
			757707-0013	1.28	V-Band	V-Band	External	N	
			757707-0014	1.01	T4	V-Band	External	Y	
			757707-0015	1.15	T4	V-Band	External	Y	
			757707-0016	1.28	T4	V-Band	External	Y	

Garrett GXR42-72

Horsepower: 700 - 1450
Displacement: 2.0L - 7.0L

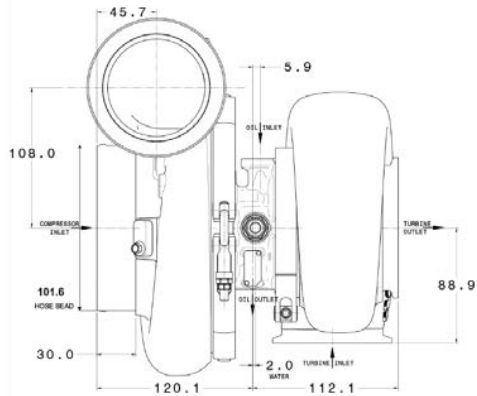

COMPRESSOR MAP

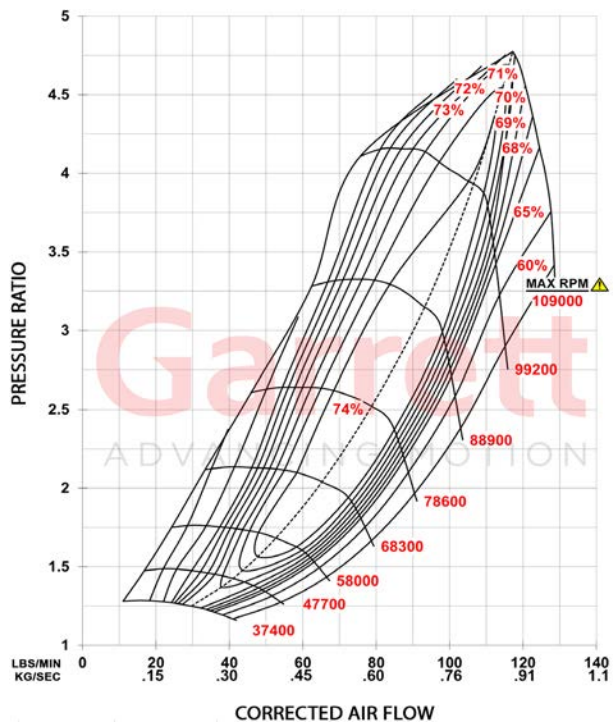

FEATURES:

- ◆ XBOOST TECHNOLOGY INCREASES POWER AND PERFORMANCE
- ◆ ENHANCED PRESSURE RATIO CAPABILITY AND HIGHER BOOST PRESSURE
- ◆ INCREASED EFFICIENCY AT HIGH FLOW RATES
- ◆ LOWER INTAKE TEMPERATURE
- ◆ LIGHTWEIGHT ALUMINUM BACKPLATE
- ◆ TWIN-SCROLL T4 AND V-BAND TURBINE INLET FLANGES AVAILABLE FOR RACERS WITH DIFFERENT ENGINES AND MANIFOLD DESIGNS

EXHAUST FLOW CHART

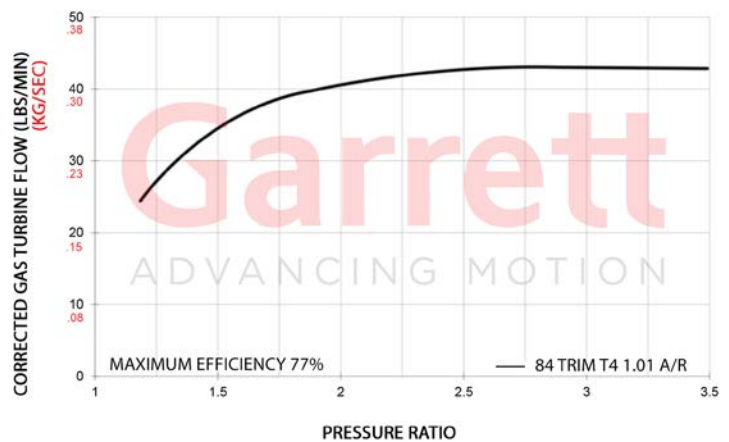

GXR42-72	Compressor				Turbine				
	HP: 700-1450	Disp: 2.0L-7.0L	Inducer	Exducer	Trim	A/R	Inducer	Exducer	Trim
			72.9mm	102mm	51	0.85	82mm	75mm	84
Supercore		PN							
Standard Rotation		934173-5002S							
Turbine Kits:			PN	A/R	Inlet	Outlet	Wastegate	Divided	
Free Float			757707-0011	1.01	V-Band	V-Band	External	N	
			757707-0012	1.15	V-Band	V-Band	External	N	
			757707-0013	1.28	V-Band	V-Band	External	N	
			757707-0014	1.01	T4	V-Band	External	Y	
			757707-0015	1.15	T4	V-Band	External	Y	
			757707-0016	1.28	T4	V-Band	External	Y	

Garrett GXR45-67

Horsepower: 725 - 1475
Displacement: 2.0L - 8.0L

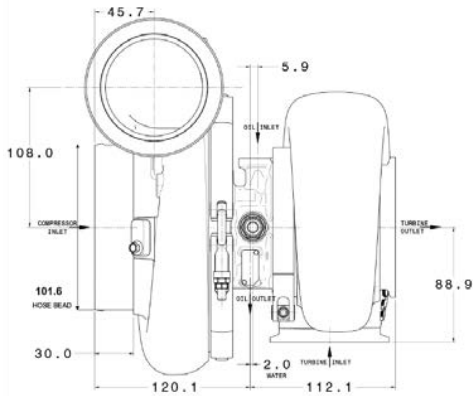

COMPRESSOR MAP

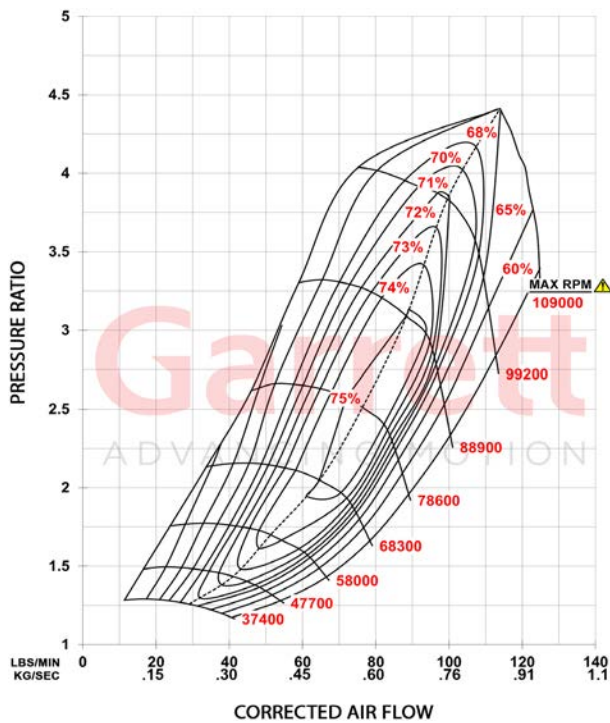

FEATURES:

- ◆ XBOOST TECHNOLOGY INCREASES POWER AND PERFORMANCE
- ◆ ENHANCED PRESSURE RATIO CAPABILITY AND HIGHER BOOST PRESSURE
- ◆ INCREASED EFFICIENCY AT HIGH FLOW RATES
- ◆ LOWER INTAKE TEMPERATURE
- ◆ LIGHTWEIGHT ALUMINUM BACKPLATE
- ◆ TWIN-SCROLL T4 AND V-BAND TURBINE INLET FLANGES AVAILABLE FOR RACERS WITH DIFFERENT ENGINES AND MANIFOLD DESIGNS

EXHAUST FLOW CHART

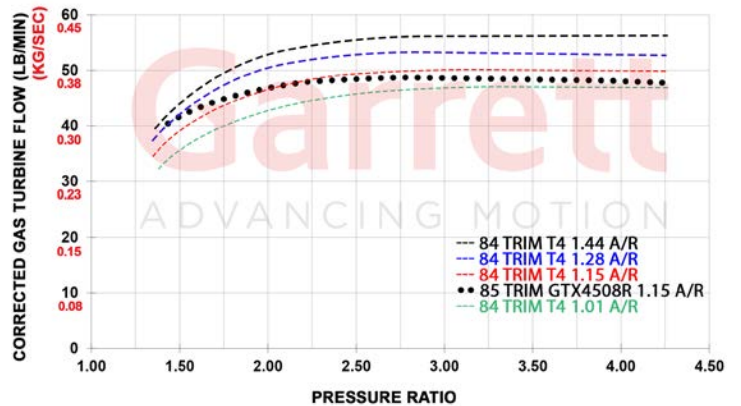

GXR45-67	Compressor				Turbine		
	Inducer	Exducer	Trim	A/R	Inducer	Exducer	Trim
HP: 725-1425 Disp: 2.0L-8.0L	67.9mm	102mm	44	0.85	89mm	82mm	84
Supercore	PN						
	934173-5003S		For classes with no map groove rule				
Optional Compressor Housing	PN						
0.25" Map Groove	934809-0009		For classes with 0.25" map groove rule (FL2K, PanAm, etc)				
Turbine Kits:	PN		A/R	Inlet	Outlet	Wastegate	Divided
Free Float	757707-0019		1.01	V-Band	V-Band	External	N
	757707-0020		1.15	V-Band	V-Band	External	N
	757707-0021		1.28	V-Band	V-Band	External	N
	757707-0022		1.44	V-Band	V-Band	External	N
	757707-0023		1.01	T4	V-Band	External	Y
	757707-0024		1.15	T4	V-Band	External	Y
	757707-0025		1.28	T4	V-Band	External	Y
	757707-0025		1.28	T4	V-Band	External	Y

Garrett GXR45-73

Horsepower: 750 - 1550
Displacement: 2.0L - 8.0L

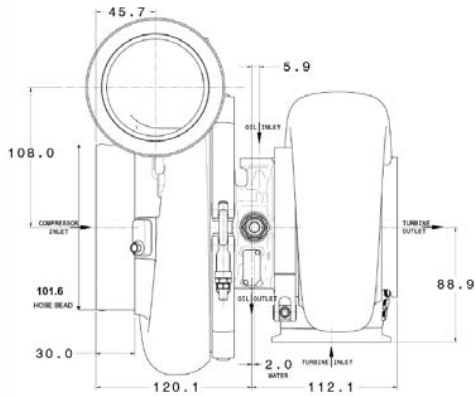

COMPRESSOR MAP

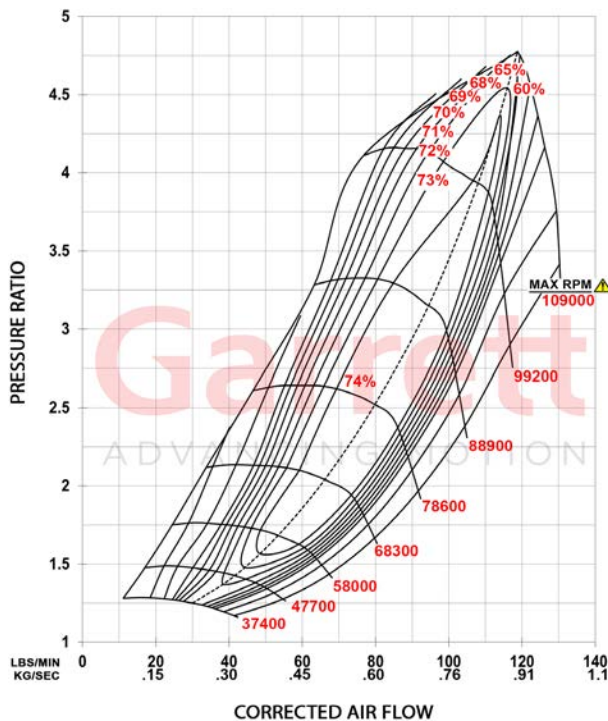

FEATURES:

- ◆ XBOOST TECHNOLOGY INCREASES POWER AND PERFORMANCE
- ◆ ENHANCED PRESSURE RATIO CAPABILITY AND HIGHER BOOST PRESSURE
- ◆ INCREASED EFFICIENCY AT HIGH FLOW RATES
- ◆ LOWER INTAKE TEMPERATURE
- ◆ LIGHTWEIGHT ALUMINUM BACKPLATE
- ◆ TWIN-SCROLL T4 AND V-BAND TURBINE INLET FLANGES AVAILABLE FOR RACERS WITH DIFFERENT ENGINES AND MANIFOLD DESIGNS

EXHAUST FLOW CHART

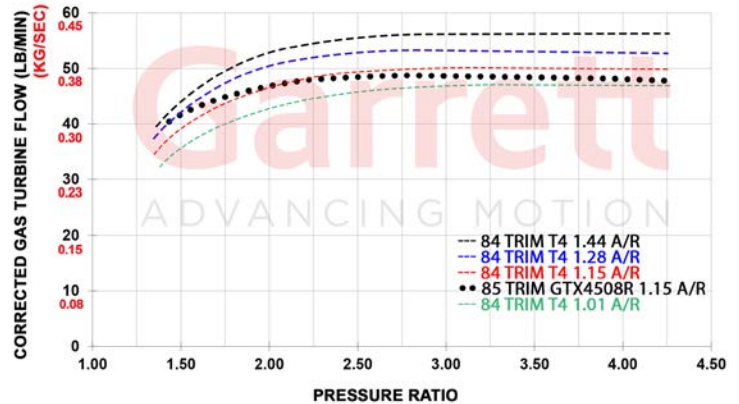

GXR45-73	Compressor				Turbine				
	HP: 750-1500	Disp: 2.0L-8.0L	Inducer	Exducer	Trim	A/R	Inducer	Exducer	Trim
			73.9mm	102mm	52	0.85	89mm	82mm	84
Supercore	PN								
	934173-5004S		For classes with no map groove rule						
Optional Compressor Housing	PN								
0.25" Map Groove	934809-0010		For classes with 0.25" map groove rule (FL2K, PanAm, etc)						
Turbine Kits:	PN		A/R	Inlet	Outlet	Wastegate	Divided		
Free Float	757707-0019		1.01	V-Band	V-Band	External	N		
	757707-0020		1.15	V-Band	V-Band	External	N		
	757707-0021		1.28	V-Band	V-Band	External	N		
	757707-0022		1.44	V-Band	V-Band	External	N		
	757707-0023		1.01	T4	V-Band	External	Y		
	757707-0024		1.15	T4	V-Band	External	Y		
	757707-0025		1.28	T4	V-Band	External	Y		
	757707-0025		1.28	T4	V-Band	External	Y		

Garrett GXR55-88

Horsepower: 1000 - 2350
Displacement: 3.0L - 12.0L

Garrett
ADVANCING MOTION

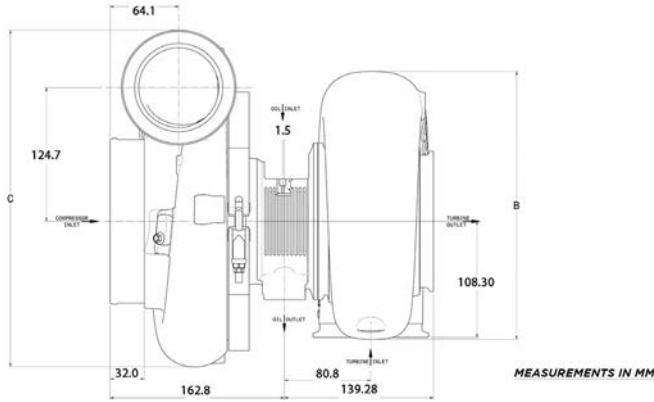

FEATURES:

- ◆ XBOOST TECHNOLOGY INCREASES POWER AND PERFORMANCE
 - ◆ +21% COMPRESSOR FLOW (GXR55-88 COMPARED TO G55-1950)
 - ◆ ENHANCED PRESSURE RATIO CAPABILITY AND HIGHER BOOST PRESSURE
 - ◆ INCREASED EFFICIENCY AT HIGH FLOW RATES
 - ◆ LOWER INTAKE TEMPERATURE
- ◆ LIGHTWEIGHT ALUMINUM BACKPLATE
- ◆ FULLY MACHINED FLANGE-STYLE SPEED SENSOR PORT FOR EASY SENSOR INSTALLATION AND MONITORING TURBO SPEED
- ◆ FOR USE IN DRAG RACE CLASSES LDR (LIMITED DRAG RADIAL), X275, AND CLASSES WITH 88MM COMPRESSOR INDUCER RULE. PLEASE VERIFY CLASS RULES BEFORE PURCHASING

COMPRESSOR MAP

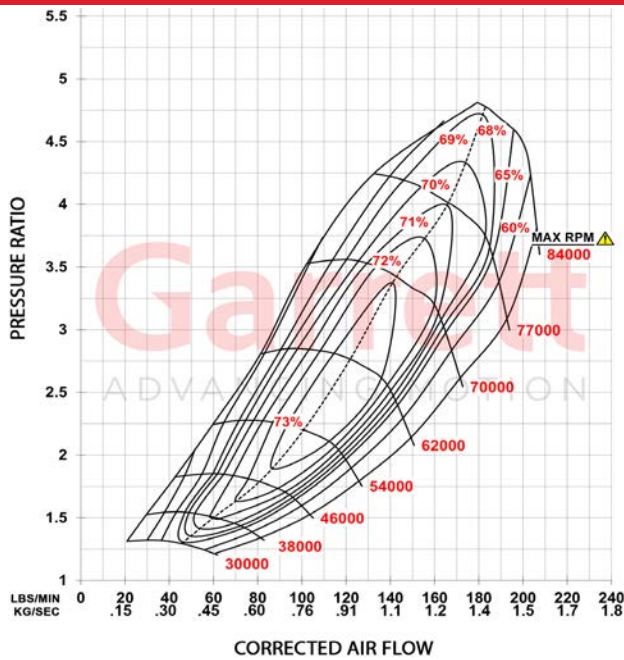

EXHAUST FLOW CHART

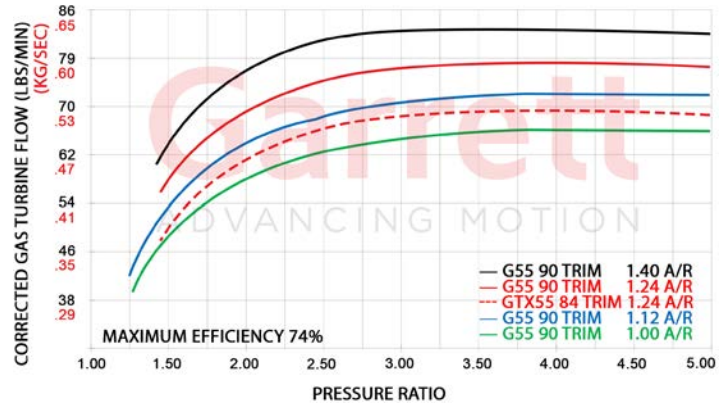

GXR55-88	Compressor				Turbine		
	Inducer	Exducer	Trim	A/R	Inducer	Exducer	Trim
HP: 1000-2350 Disp: 3.0L-12.0L	88.9mm	133mm	44	0.88	112mm	103mm	86
Supercore	PN				Drag Race Class		
0.25" Map Groove	934174-5001S				LDR, X275		
0.18" Map Groove	934174-5008S				X275		
Turbine Kits:	PN	A/R	Inlet	Outlet	Wastegate	Divided	
Free Float	761208-0086	1.24	V-Band	V-Band	External	N	
	761208-0087	1.40	V-Band	V-Band	External	N	

GXR55-88	Compressor				Turbine		
	Inducer	Exducer	Trim	A/R	Inducer	Exducer	Trim
HP: 1000-2350 Disp: 3.0L-12.0L	88.9mm	133mm	44	0.88	112mm	106mm	90
Supercore	PN				Drag Race Class		
0.18" Map Groove	934174-5002S				X275		
0.25" Map Groove	934174-5007S				X275		
Turbine Kits:	PN	A/R	Inlet	Outlet	Wastegate	Divided	
Free Float	761208-0069	1.24	V-Band	V-Band	External	N	
	761208-0070	1.40	V-Band	V-Band	External	N	
	761208-0071	1.00	T6	V-Band	External	N	
	761208-0072	1.12	T6	V-Band	External	N	
	761208-0073	1.24	T6	V-Band	External	N	
	761208-0074	1.40	T6	V-Band	External	N	

GTX SERIES

GTX and GTX Gen II Series turbochargers are an evolution of the GT Series product line. The original architecture of the GT Series turbos remains however many design and performance features have been introduced over time. Ceramic dual ball bearings and forged fully-machined compressor wheels with GTX and GTX Gen II aerodynamics provide a larger horsepower range and maximize boost response.

The water cooled center housing keeps housing temperatures to a minimum. The turbine wheel is constructed from Inconel, a super alloy that maintains strength over prolonged exposure to high exhaust gas temperatures.

Turbine kits are offered in open volute and twin scroll, and a variety of A/R and flange configurations from T25, T3, T4, T6, and V-band.

GEN II PRODUCT UPDATES UPDATED FEATURES ON SELECT GTX TURBOCHARGERS



GEN II COMPRESSOR AERODYNAMICS FOR INCREASED HORSEPOWER RANGE (GTX28/30/35/47/50/ 55)
FULLY MACHINED SPEED SENSOR PORT FOR DATA ACQUISITION (GTX28/30/35/47/50/55)
LIGHTWEIGHT ALUMINUM BACKPLATE FOR WEIGHT REDUCTION (GTX47/50/55)





ON RACEWORKS

13

Garrett GTX2860R GEN II

Horsepower: 200 - 475
Displacement: 1.4L - 2.5L

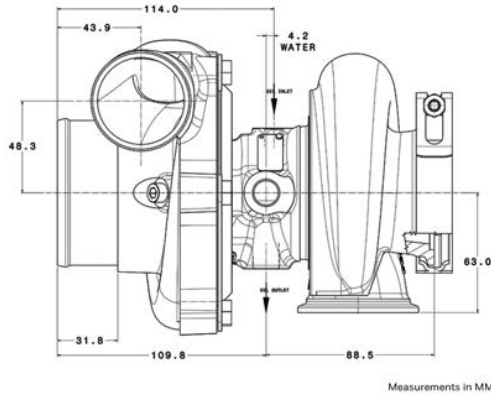

COMPRESSOR MAP

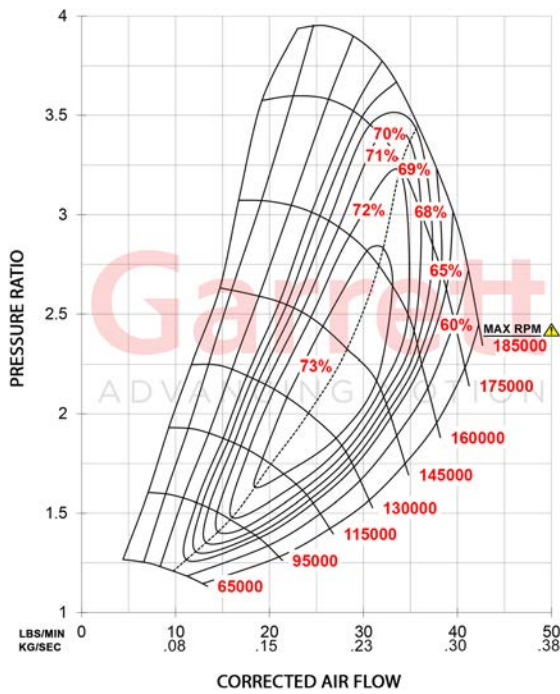

FEATURES:

- ◆ GEN 2 AERODYNAMICS FEATURE INCREASED HORSEPOWER RANGE
- ◆ IMPROVED PORTED SHROUD DESIGN FOR SURGE RESISTANCE
- ◆ FULLY-MACHINED SPEED SENSOR PORT. DETAILS ON PG. 80
- ◆ WASTEGATE ACTUATORS & BRACKET KIT AVAILABLE ON PG. 81

EXHAUST FLOW CHART

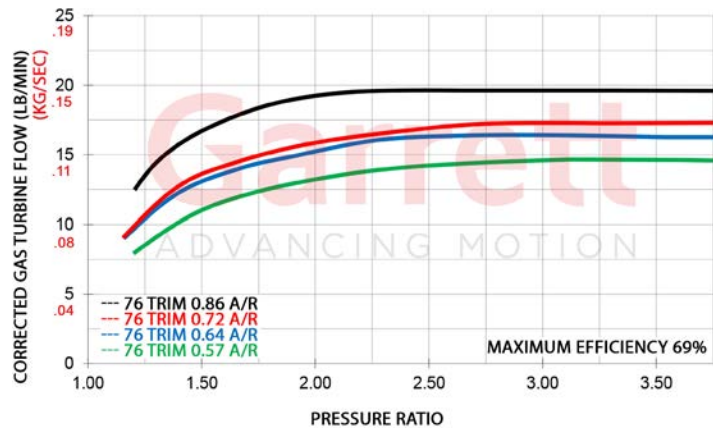

GTX2860R Gen II		Compressor				Turbine		
		Inducer	Exducer	Trim	A/R	Inducer	Exducer	Trim
HP: 200-475	Disp: 1.4L-2.5L	46mm	60mm	58	0.60	54mm	47mm	76
Supercore	Assembly Kit	Turbine Kit		A/R	Inlet	Outlet	Wastegate	Divided
849894-5001S	856800-5001S	827690-0001		0.57	V-Band	V-Band	Free Float	N
	856800-5002S	827690-0002		0.72	V-Band	V-Band	Free Float	N
Assembly Kit PN Includes	856800-5003S	827690-0003		0.64	T25	5 bolt	Wastegated	N
Supercore and Turbine Kit	856800-5004S	827690-0004		0.86	T25	5 bolt	Wastegated	N

Garrett GTX2867R GEN II

Horsepower: 275 - 550

Displacement: 1.4L - 2.5L

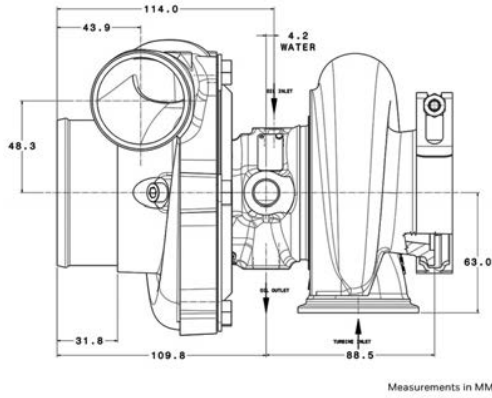

COMPRESSOR MAP

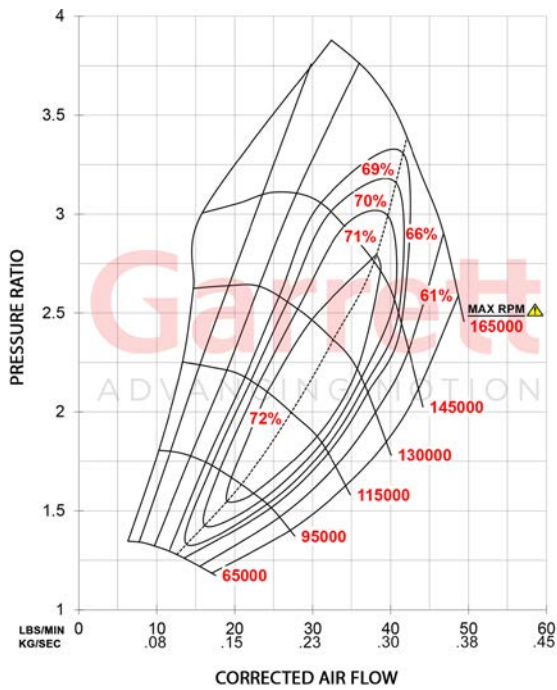

FEATURES:

- ◆ GEN 2 AERODYNAMICS FEATURE INCREASED HORSEPOWER RANGE
- ◆ IMPROVED PORTED SHROUD DESIGN FOR SURGE RESISTANCE
- ◆ FULLY-MACHINED SPEED SENSOR PORT. DETAILS ON PG. 80
- ◆ WASTEGATE ACTUATORS & BRACKET KIT AVAILABLE ON PG. 81

EXHAUST FLOW CHART

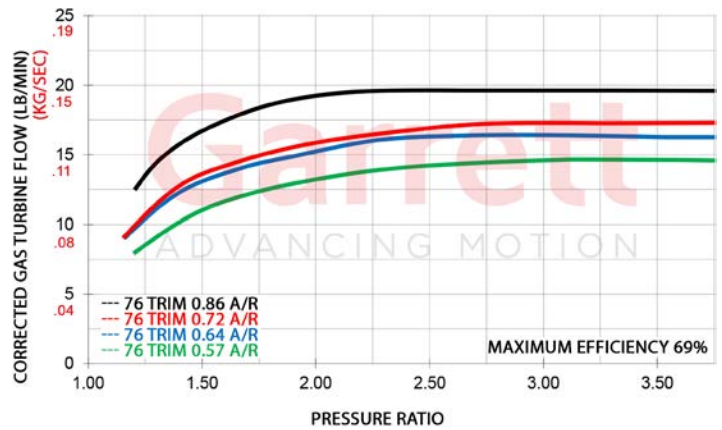

GTX2867R Gen II		Compressor				Turbine		
		Inducer	Exducer	Trim	A/R	Inducer	Exducer	Trim
HP: 275-550	Disp: 1.4L-2.5L	50mm	67mm	55	0.60	54mm	47mm	76
Supercore	Assembly Kit	Turbine Kit		A/R	Inlet	Outlet	Wastegate	Divided
849894-5002S	856800-5005S	827690-0001		0.57	V-Band	V-Band	Free Float	N
	856800-5006S	827690-0002		0.72	V-Band	V-Band	Free Float	N
Assembly Kit PN Includes	856800-5007S	827690-0003		0.64	T25	5 bolt	Wastegated	N
Supercore and Turbine Kit	856800-5008S	827690-0004		0.86	T25	5 bolt	Wastegated	N

Garrett GTX3071R GEN II

Horsepower: 340 - 675
Displacement: 1.8L - 3.0L

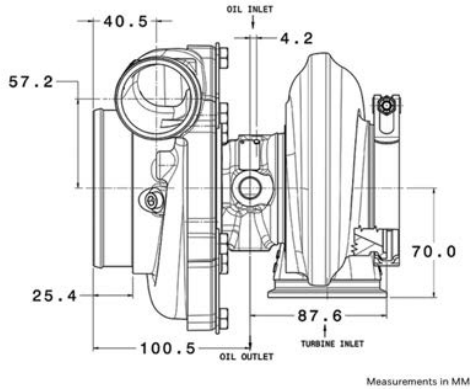

COMPRESSOR MAP

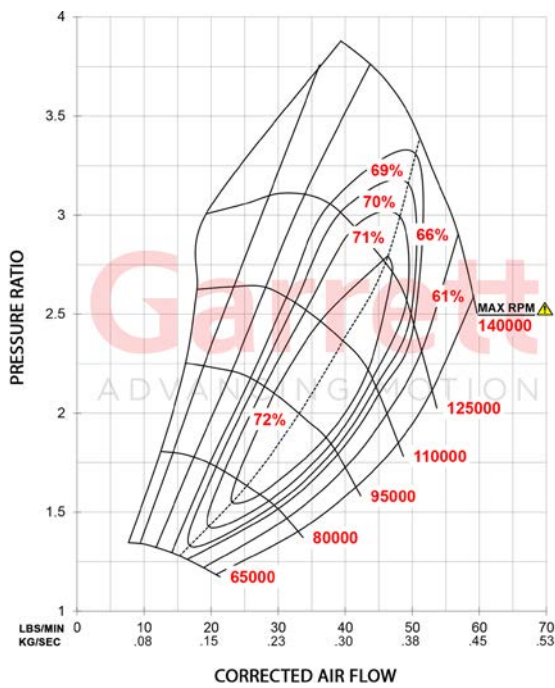

FEATURES:

- ◆ GEN 2 AERODYNAMICS FEATURE INCREASED HORSEPOWER RANGE
- ◆ FULLY-MACHINED SPEED SENSOR PORT. DETAILS ON PG. 80
- ◆ WASTEGATE ACTUATORS & BRACKET KIT AVAILABLE ON PG. 81
- ◆ REVERSE ROTATION CONFIGURATIONS AVAILABLE

EXHAUST FLOW CHART

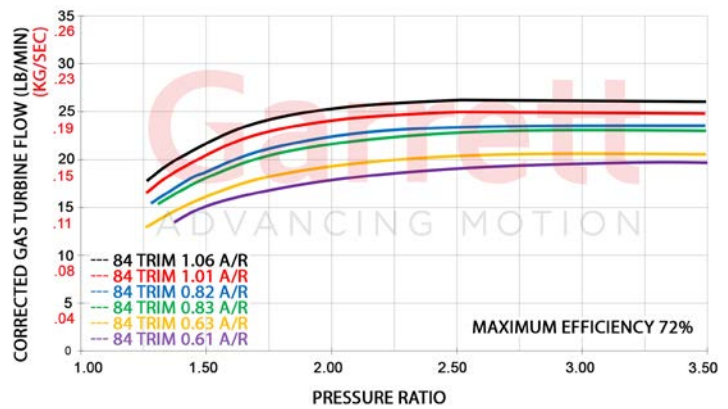

GTX3071R Gen II		Compressor				Turbine		
		Inducer	Exducer	Trim	A/R	Inducer	Exducer	Trim
HP: 340-675	Disp: 1.8L-3.0L	54mm	71mm	58	0.60	60mm	55mm	84
Supercore	Assembly Kit	Turbine Kit		A/R	Inlet	Outlet	Wastegate	Divided
851154-5002S	856801-5006S	740902-0009	0.63	T3	V-Band	Free Float	N	
	856801-5005S	740902-0008	0.82	T3	V-Band	Free Float	N	
		740902-0007	1.06	T3	V-Band	Free Float	N	
	856801-5018S	740902-0036	0.61	V-Band	V-Band	Free Float	N	
	856801-5017S	740902-0035	0.83	V-Band	V-Band	Free Float	N	
		740902-0034	1.01	V-Band	V-Band	Free Float	N	
		771300-0006	0.63	T3	5 bolt	Wastegated	N	
Assembly Kit PN Includes		771300-0005	0.82	T3	5 bolt	Wastegated	N	
Supercore and Turbine Kit		771300-0004	1.06	T3	5 bolt	Wastegated	N	
Reverse Rotation	Supercore	Turbine Kit		A/R	Inlet	Outlet	Wastegate	Divided
	844621-5003S	740902-0053	0.61	V-Band	V-Band	Free Float	N	
		740902-0054	0.83	V-Band	V-Band	Free Float	N	
		740902-0055	1.01	V-Band	V-Band	Free Float	N	

Garrett GTX3076R GEN II



Horsepower: 400 - 750
Displacement: 1.8L - 3.0L

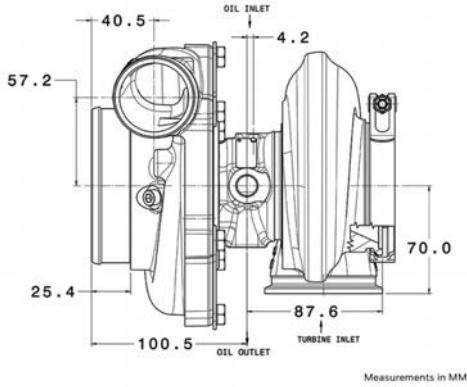

Measurements in MM

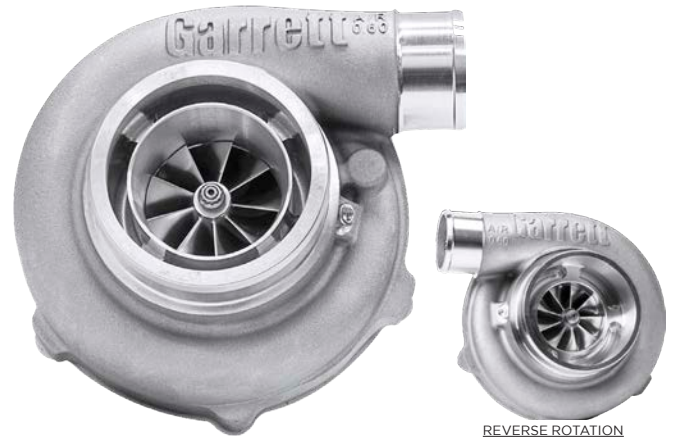

REVERSE ROTATION

COMPRESSOR MAP

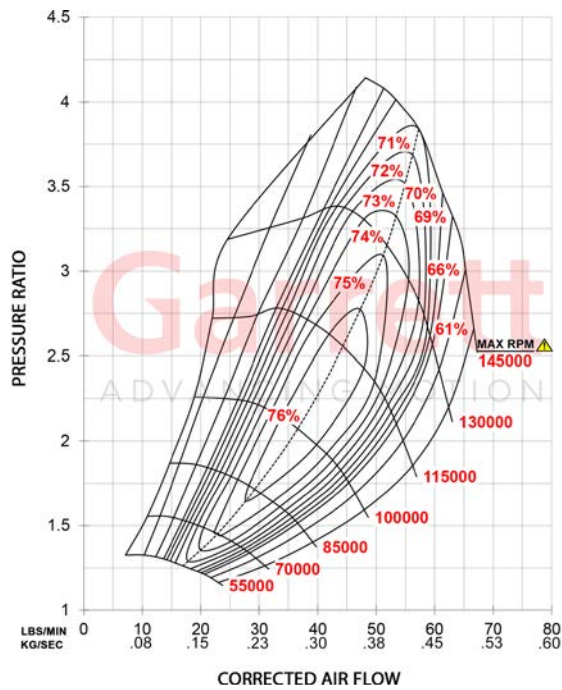

FEATURES:

- ◆ GEN 2 AERODYNAMICS FEATURE INCREASED HORSEPOWER RANGE
- ◆ FULLY-MACHINED SPEED SENSOR PORT. DETAILS ON PG. 80
- ◆ WASTEGATE ACTUATORS & BRACKET KIT AVAILABLE ON PG. 81
- ◆ REVERSE ROTATION OPTIONS AVAILABLE

EXHAUST FLOW CHART

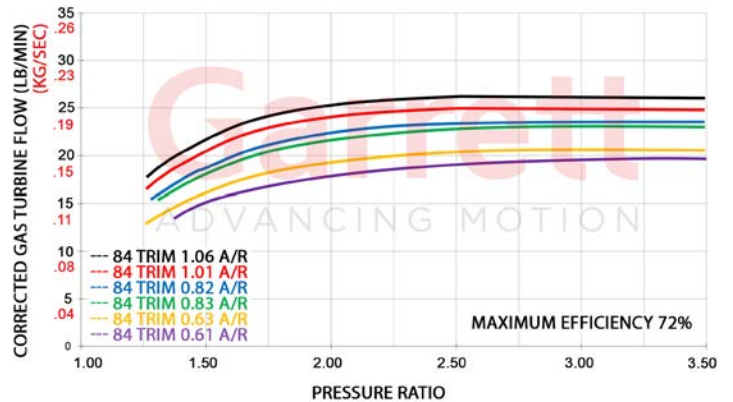

GTX3076R Gen II		Compressor				Turbine		
		Inducer	Exducer	Trim	A/R	Inducer	Exducer	Trim
HP: 400-750	Disp: 1.8L-3.0L	58mm	76mm	58	0.60	60mm	55mm	84
Supercore	Assembly Kit	Turbine Kit		A/R	Inlet	Outlet	Wastegate	Divided
851154-5001S	856801-5027S	740902-0009	0.63	T3	V-Band	Free Float	N	
	856801-5026S	740902-0008	0.82	T3	V-Band	Free Float	N	
		740902-0007	1.06	T3	V-Band	Free Float	N	
		740902-0036	0.61	V-Band	V-Band	Free Float	N	
	856801-5038S	740902-0035	0.83	V-Band	V-Band	Free Float	N	
	856801-5037S	740902-0034	1.01	V-Band	V-Band	Free Float	N	
		771300-0006	0.63	T3	5 bolt	Wastegated	N	
Assembly Kit PN Includes Supercore and Turbine Kit		771300-0005	0.82	T3	5 bolt	Wastegated	N	
		771300-0004	1.06	T3	5 bolt	Wastegated	N	
	Reverse Rotation	Supercore	Turbine Kit		A/R	Inlet	Outlet	Wastegate
	844621-5004S	740902-0053	0.61	V-Band	V-Band	Free Float	N	
		740902-0054	0.83	V-Band	V-Band	Free Float	N	
		740902-0055	1.01	V-Band	V-Band	Free Float	N	

Garrett GTX3576R GEN II



Horsepower: 400 - 750
Displacement: 2.0L- 4.5L

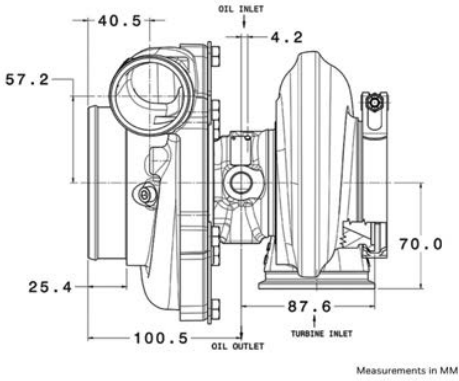

COMPRESSOR MAP

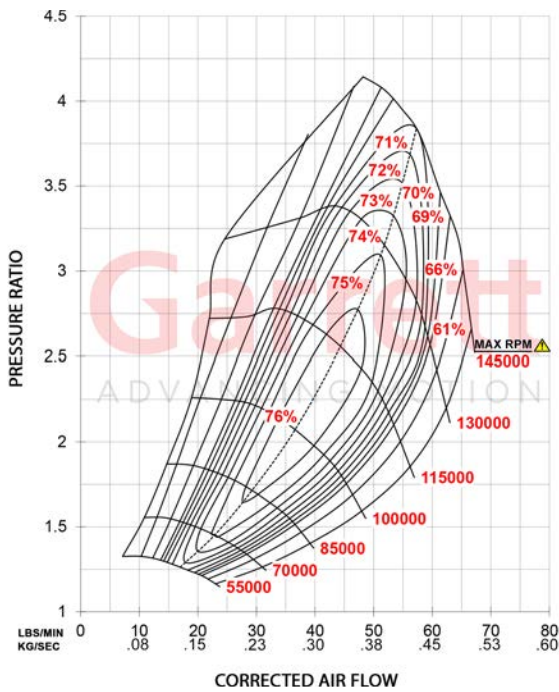

- FEATURES:**
- ◆ GEN 2 AERODYNAMICS FEATURE INCREASED HORSEPOWER RANGE
 - ◆ FULLY-MACHINED SPEED SENSOR PORT. DETAILS ON PG. 80
 - ◆ REVERSE ROTATION OPTIONS AVAILABLE

EXHAUST FLOW CHART

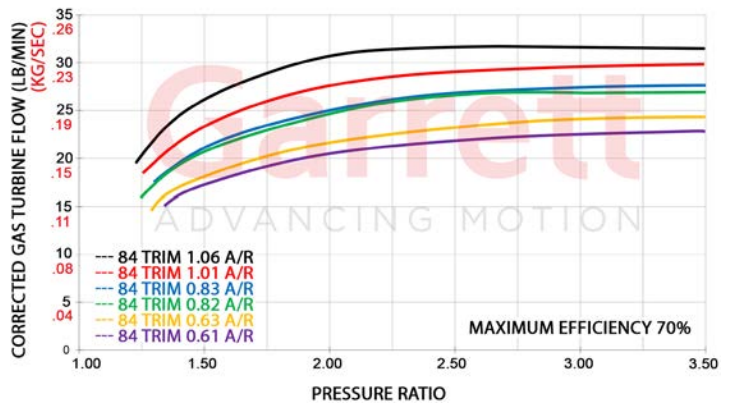

GTX3576R Gen II		Compressor				Turbine		
		Inducer	Exducer	Trim	A/R	Inducer	Exducer	Trim
HP: 400-750	Disp: 2.0L-4.5L	58mm	76mm	58	0.60	68mm	62mm	84
Supercore	Assembly Kit	Turbine Kit		A/R	Inlet	Outlet	Wastegate	Divided
851154-5003S		740902-0012		0.63	T3	V-Band	Free Float	N
		740902-0011		0.82	T3	V-Band	Free Float	N
		740902-0010		1.06	T3	V-Band	Free Float	N
		740902-0018		0.63	T4	V-Band	Free Float	N
		740902-0017		0.82	T4	V-Band	Free Float	N
		740902-0016		1.06	T4	V-Band	Free Float	N
		740902-0033		0.61	V-Band	V-Band	Free Float	N
Assembly Kit PN Includes Supercore and Turbine Kit	856801-5059S	740902-0032		0.83	V-Band	V-Band	Free Float	N
	856801-5058S	740902-0031		1.01	V-Band	V-Band	Free Float	N
Reverse Rotation	Supercore	Turbine Kit		A/R	Inlet	Outlet	Wastegate	Divided
	844626-5003S	740902-0056		0.61	V-Band	V-Band	Free Float	N
		740902-0057		0.83	V-Band	V-Band	Free Float	N
		740902-0058		1.01	V-Band	V-Band	Free Float	N

Garrett GTX3582R GEN II



Horsepower: 450 - 900
Displacement: 2.0L - 4.5L

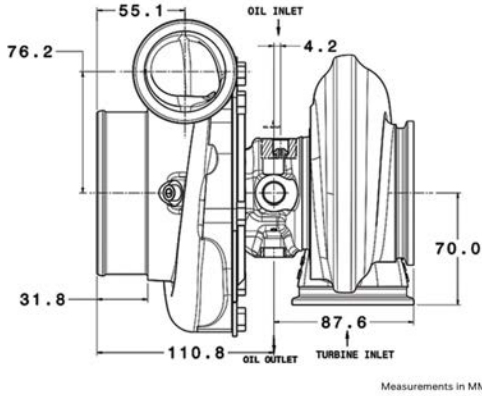

REVERSE ROTATION

COMPRESSOR MAP

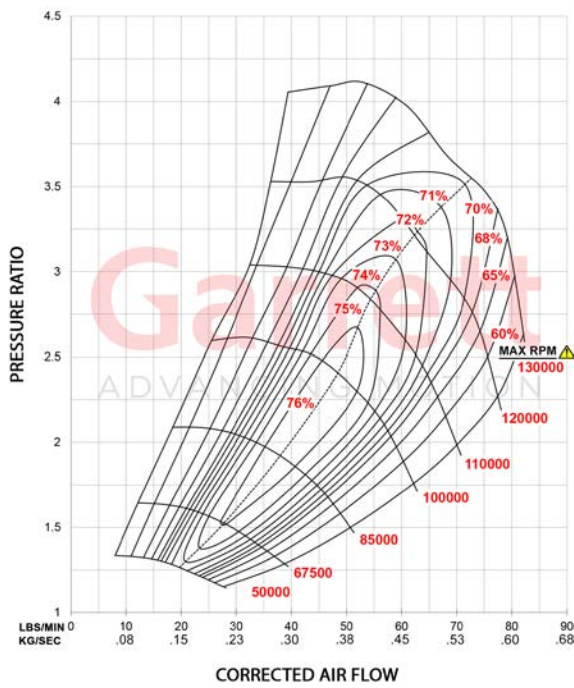

FEATURES:

- ◆ GEN 2 AERODYNAMICS FEATURE INCREASED HORSEPOWER RANGE
- ◆ FULLY-MACHINED SPEED SENSOR PORT. DETAILS ON PG. 80
- ◆ REVERSE ROTATION OPTIONS AVAILABLE

EXHAUST FLOW CHART

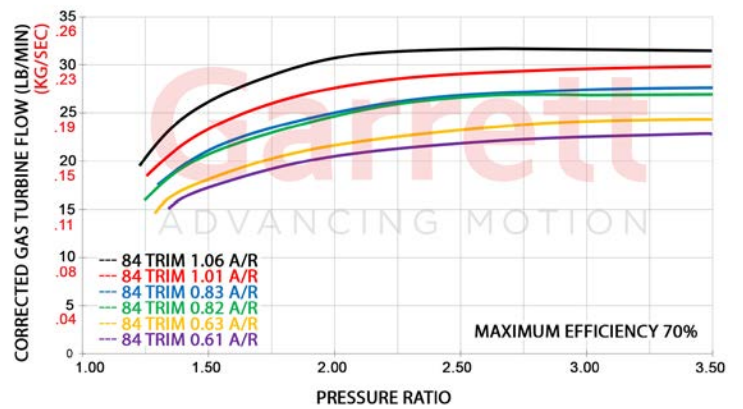

GTX3582R Gen II		Compressor				Turbine		
		Inducer	Exducer	Trim	A/R	Inducer	Exducer	Trim
HP: 450-900	Disp: 2.0L-4.5L	66mm	82mm	64	0.70	68mm	62mm	84
Supercore	Assembly Kit	Turbine Kit		A/R	Inlet	Outlet	Wastegate	Divided
851154-5004S	856801-5068S	740902-0012	0.63	T3	V-Band	Free Float	N	
		740902-0011	0.82	T3	V-Band	Free Float	N	
		740902-0010	1.06	T3	V-Band	Free Float	N	
		740902-0018	0.63	T4	V-Band	Free Float	N	
		740902-0017	0.82	T4	V-Band	Free Float	N	
856801-5071S	740902-0016	740902-0016	1.06	T4	V-Band	Free Float	N	
		740902-0033	0.61	V-Band	V-Band	Free Float	N	
		740902-0032	0.83	V-Band	V-Band	Free Float	N	
Assembly Kit PN Includes Supercore and Turbine Kit	856801-5080S	740902-0031	1.01	V-Band	V-Band	Free Float	N	
	856801-5079S	740902-0031	1.01	V-Band	V-Band	Free Float	N	
Reverse Rotation	Supercore	Turbine Kit		A/R	Inlet	Outlet	Wastegate	Divided
	844626-5004S	740902-0056	0.61	V-Band	V-Band	Free Float	N	
		740902-0057	0.83	V-Band	V-Band	Free Float	N	
740902-0058		1.01	V-Band	V-Band	Free Float	N		

Garrett GTX3584RS

Horsepower: 550 - 1000
Displacement: 2.0L - 5.5L

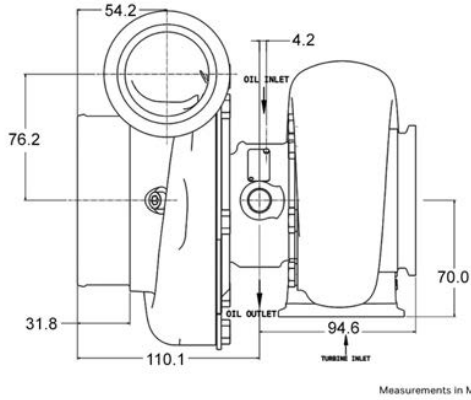

COMPRESSOR MAP

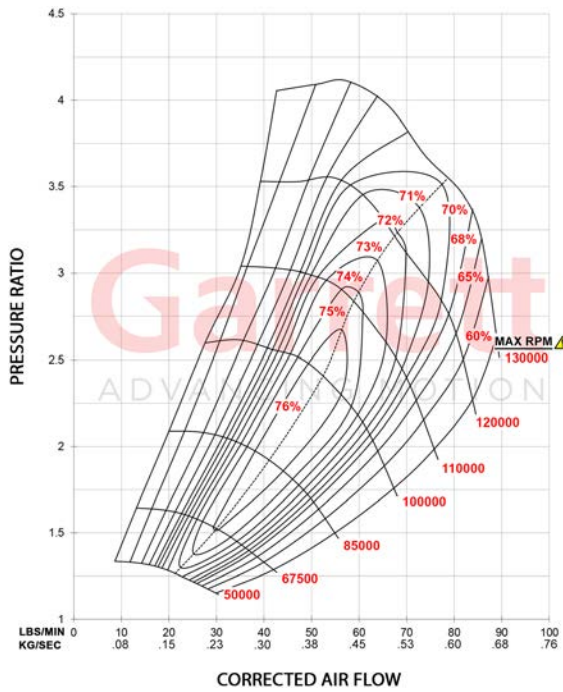

FEATURES:

- ◆ GEN 2 AERODYNAMICS FEATURE INCREASED HORSEPOWER RANGE
- ◆ "RS" HIGH FLOWING TURBINE WHEEL
- ◆ COMPACT DESIGN FOR TIGHT INSTALLATIONS
- ◆ FULLY-MACHINED SPEED SENSOR PORT. DETAILS ON PG. 80
- ◆ COMP OUTLET AVAILABLE IN V-BAND & HOSE CONNECTION

EXHAUST FLOW CHART

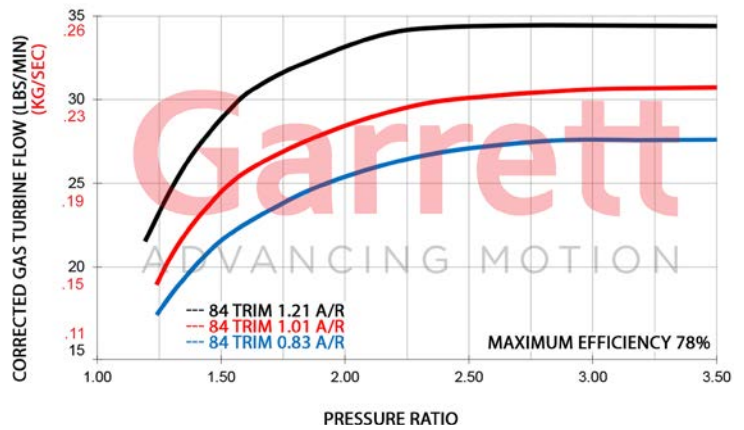

GTX3584RS		Compressor				Turbine		
		Inducer	Exducer	Trim	A/R	Inducer	Exducer	Trim
HP: 550-1000	Disp: 2.0L-5.5L	67mm	84mm	64	0.72	68mm	62mm	84
Supercore	Assembly Kit	Turbine Kit		A/R	Inlet	Outlet	Wastegate	Divided
846098-5001S	856804-5001S	740902-0067		0.83	V-Band	V-Band	Free Float	N
Hose bead comp outlet	856804-5002S	740902-0066		1.01	V-Band	V-Band	Free Float	N
		740902-0052		1.21	V-Band	V-Band	Free Float	N
846098-5002S		740902-0067		0.83	V-Band	V-Band	Free Float	N
V-band comp outlet		740902-0066		1.01	V-Band	V-Band	Free Float	N
		740902-0052		1.21	V-Band	V-Band	Free Float	N

*GTX3584 turbine housings not compatible with GT/GTX35 housings

Garrett GTX4088R

Horsepower: 460 - 850
 Displacement: 2.0L - 6.0L

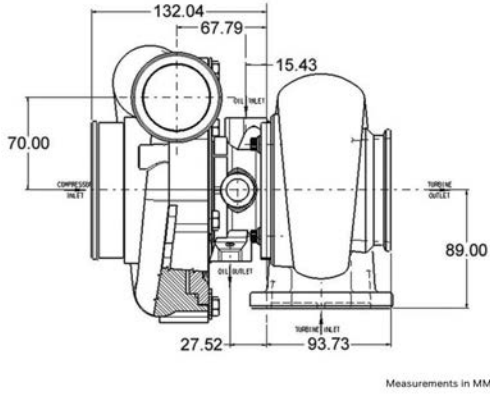

COMPRESSOR MAP

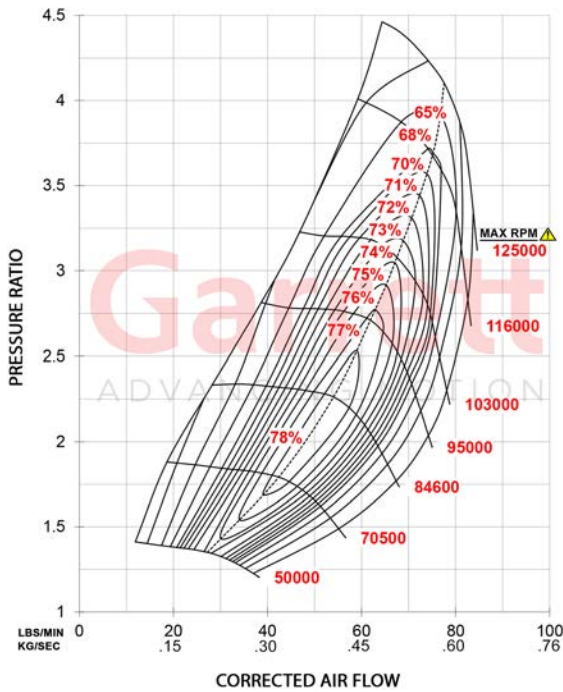

FEATURES:

- ◆ FEATURES ORIGINAL GTX COMP WHEEL AERODYNAMICS
- ◆ SUPERCORE AND TURBINE KIT SOLD SEPARATELY
- ◆ AVAILABLE ONLY WITH DIVIDED TURBINE HOUSINGS

EXHAUST FLOW CHART

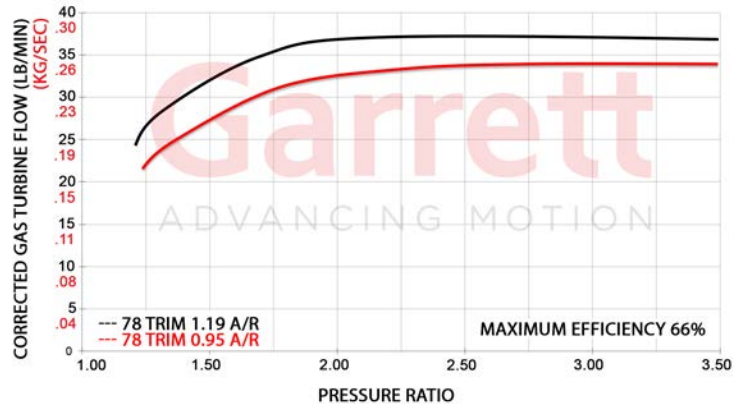

GTX4088R		Compressor				Turbine		
HP: 460-850	Disp: 2.0L-6.0L	Inducer	Exducer	Trim	A/R	Inducer	Exducer	Trim
Supercore		65mm	88mm	54	0.72	77mm	68mm	78
Standard Rotation		PN 825614-5005S						
Turbine Kits: GTX40		PN	A/R	Inlet	Outlet	Wastegate	Divided	
Free Float		773628-0011	0.95	T4	V-Band	External	Y	
		773628-0013	1.19	T4	V-Band	External	Y	

Garrett GTX4294R

Horsepower: 475 - 950
Displacement: 2.0L - 7.0L

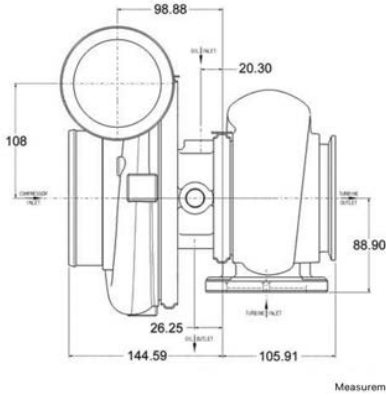

COMPRESSOR MAP

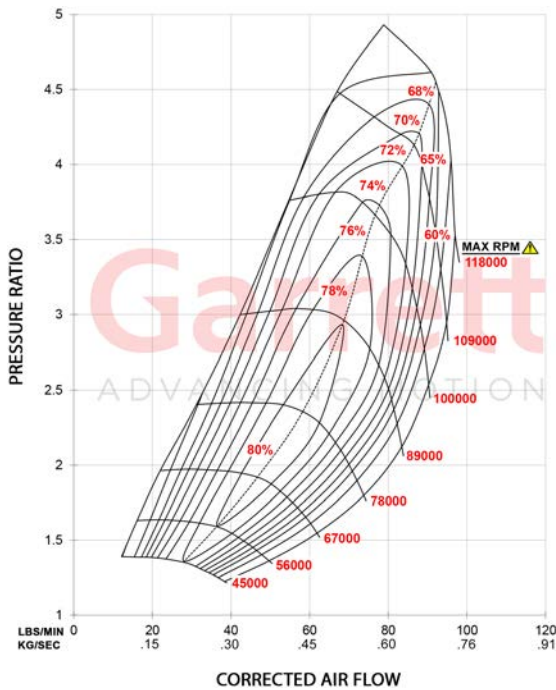

FEATURES:

- ◆ FEATURES ORIGINAL GTX COMP WHEEL AERODYNAMICS
- ◆ SUPERCORE AND TURBINE KIT SOLD SEPARATELY
- ◆ AVAILABLE ONLY WITH DIVIDED TURBINE HOUSINGS
- ◆ V-BAND COMPRESSOR OUTLET CONFIGURATION

EXHAUST FLOW CHART

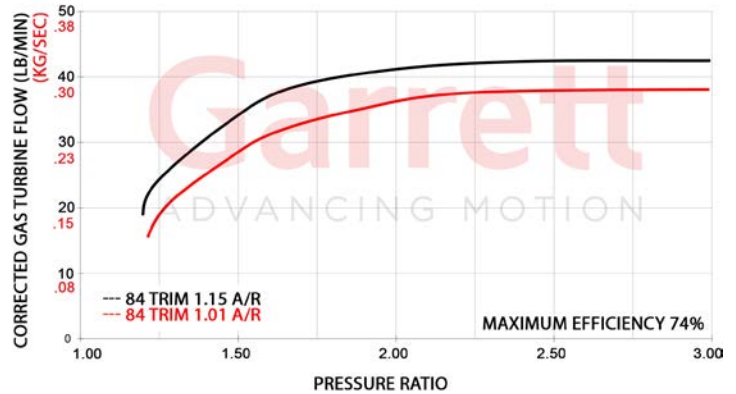

GTX4294R	Compressor				Turbine		
	Inducer	Exducer	Trim	A/R	Inducer	Exducer	Trim
HP: 475-950 Disp: 2.0L-7.0L	70mm	94mm	56	0.60	82mm	75mm	84
Supercore	PN						
Standard Rotation	800269-5001S						
Turbine Kits: GTX42	PN		A/R	Inlet	Outlet	Wastegate	Divided
Free Float	757707-0002		1.15	T4	V-Band	External	Y
	757707-0003		1.28	T4	V-Band	External	Y
	757707-0004		1.44	T4	V-Band	External	Y

Garrett GTX4202R

Horsepower: 525 - 1120
Displacement: 2.0L - 7.0L

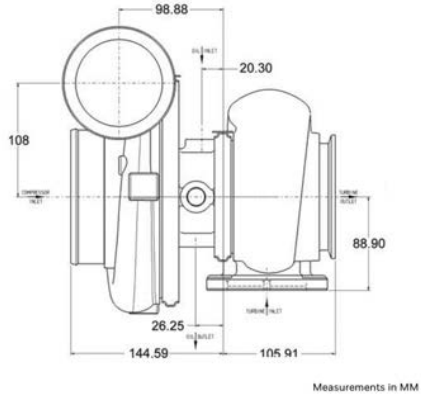

COMPRESSOR MAP

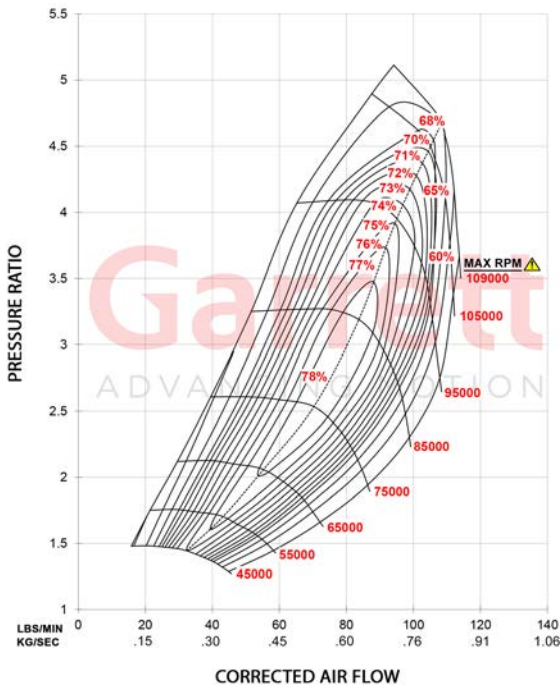

FEATURES:

- ◆ FEATURES ORIGINAL GTX COMP WHEEL AERODYNAMICS
- ◆ SUPERCORE AND TURBINE KIT SOLD SEPARATELY
- ◆ AVAILABLE ONLY WITH DIVIDED TURBINE HOUSINGS
- ◆ V-BAND COMPRESSOR OUTLET CONFIGURATION

EXHAUST FLOW CHART

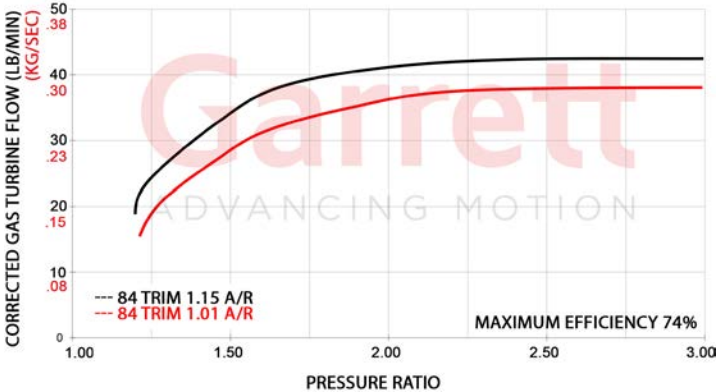

GTX4202R		Inducer	Exducer	Trim	A/R	Inducer	Exducer	Trim
HP: 525-1120	Disp: 2.0L-7.0L	76mm	102mm	55	0.60	82mm	75mm	84
Supercore		PN						
Standard Rotation		800269-5002S						
Turbine Kits: GTX42		PN		A/R	Inlet	Outlet	Wastegate	Divided
Free Float		757707-0002		1.15	T4	V-Band	External	Y
		757707-0003		1.28	T4	V-Band	External	Y
		757707-0004		1.44	T4	V-Band	External	Y

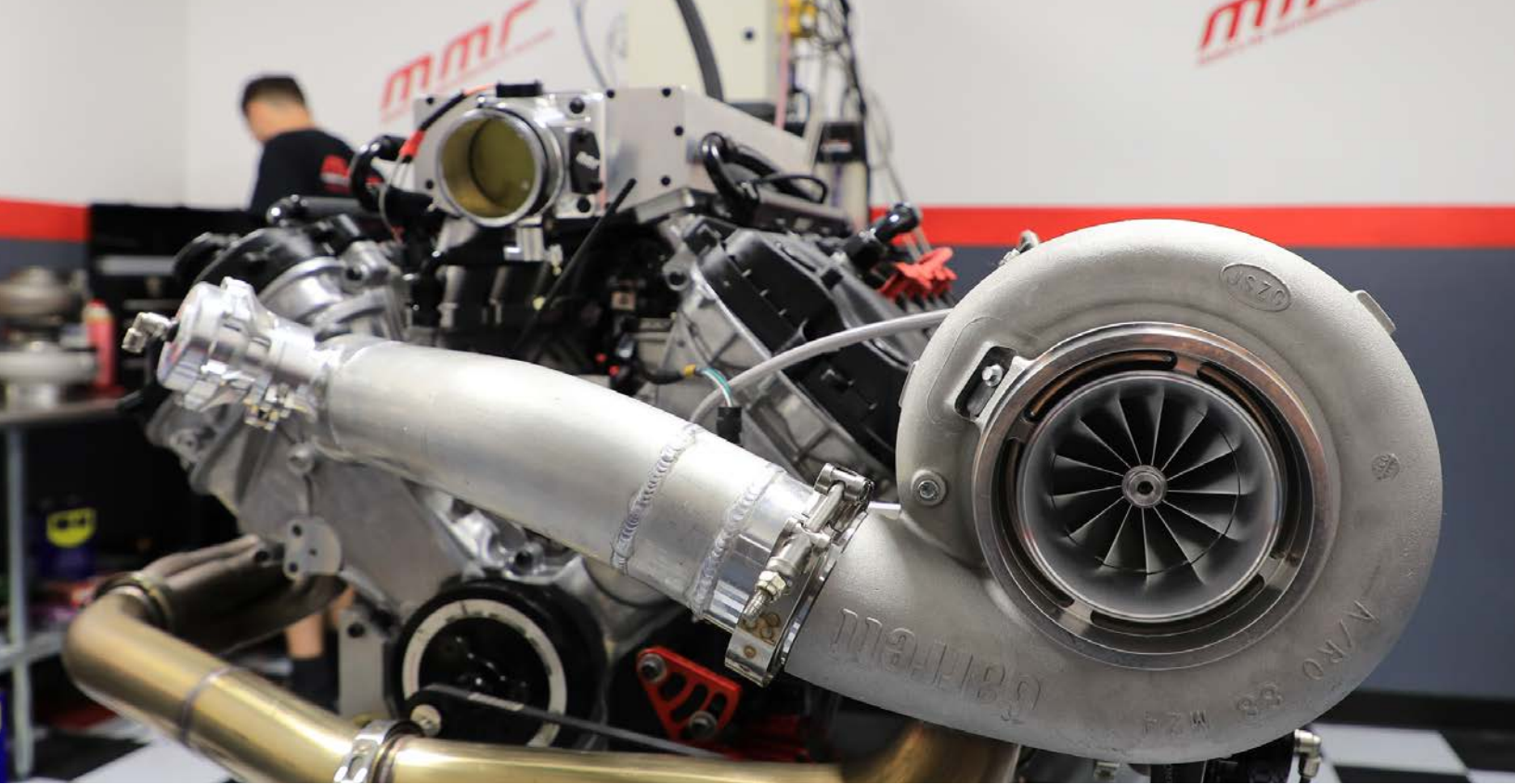

Mark Luton (left) and Greg Seth-Hunter (right) inside the MMR dynocell. The Superflow dyno allows them to test components for performance gains without having to take the racecar to the track.



The turbochargers tested are the GTX5020R Gen II 76mm, 80mm, 88mm, and the GTX5533R Gen II 94mm. Tuning is performed by Mark Luton using Fuel Tech software.

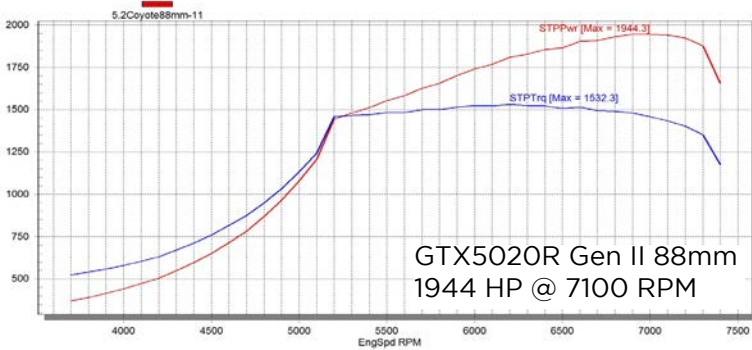

Mark Luton (left) and Greg Seth-Hunter (right) inside the MMR dynocell. The Superflow dyno allows them to test components for performance gains without having to take the racecar to the track.

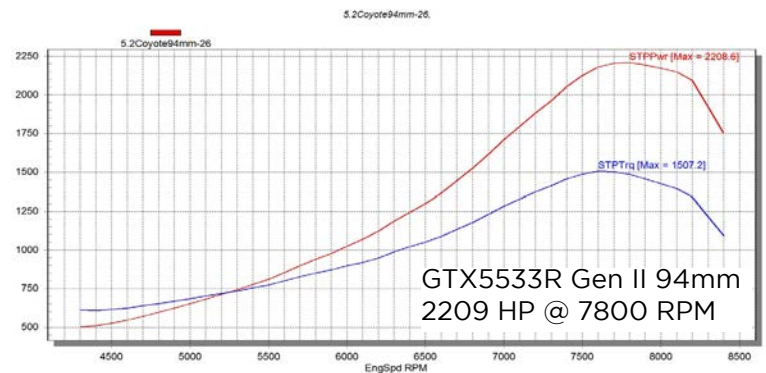

Mark Luton (left) and Greg Seth-Hunter (right) inside the MMR dynocell. The Superflow dyno allows them to test components for performance gains without having to take the racecar to the track.

Garrett GTX4709R GEN II

Horsepower: 825 - 1625
Displacement: 2.0L - 10.0L

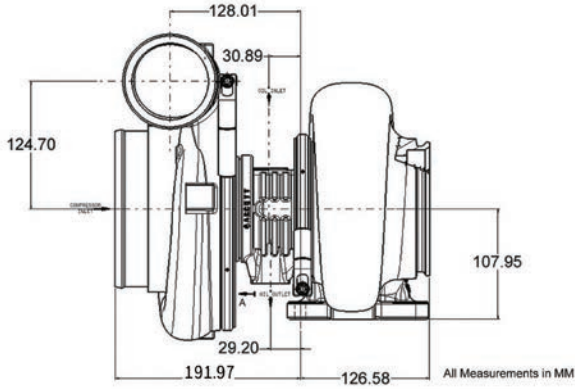

COMPRESSOR MAP

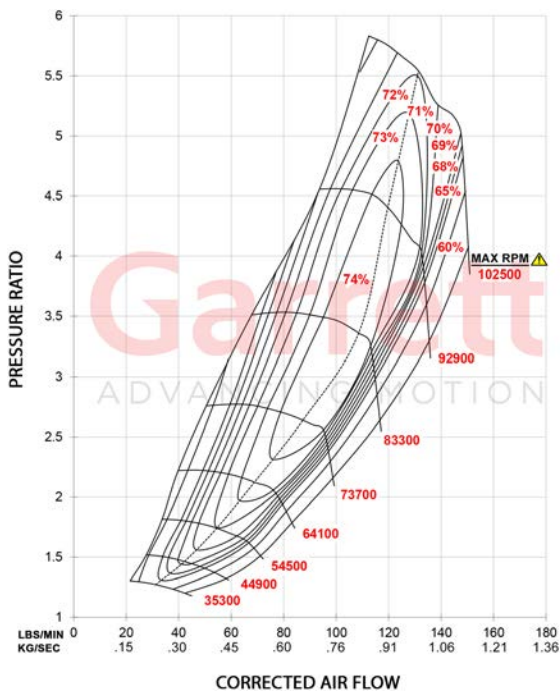

FEATURES:

- ◆ GEN 2 COMPRESSOR WHEEL AERODYNAMICS
- ◆ 15% INCREASED COMPRESSOR FLOW
- ◆ 76MM, 80MM, INDUCER CONFIGURATIONS
- ◆ .88 A/R COMPRESSOR HOUSING VOLUTE
- ◆ 39% LOWER INERTIA THAN PREVIOUS GENERATION
- ◆ SUPERCORE AND TURBINE HOUSING SOLD SEPARATELY
- ◆ COMPATIBLE WITH GT AND GTX GEN I TURBINE HOUSINGS

EXHAUST FLOW CHART

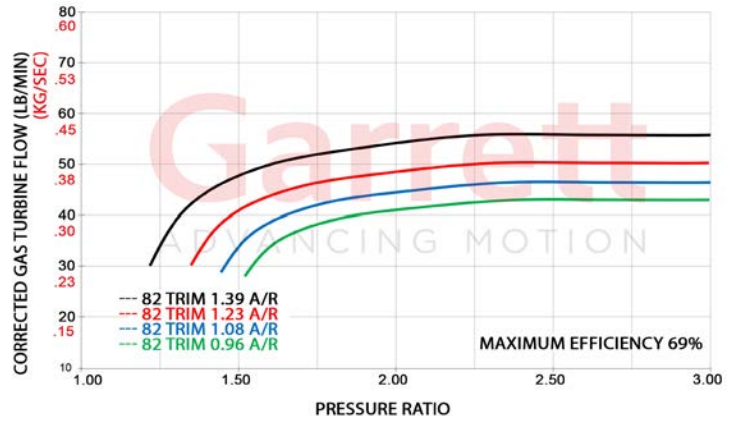

GTX4709R Gen II		Compressor				Turbine		
HP: 825-1625	Disp: 2.0L-10.0L	Inducer	Exducer	Trim	A/R	Inducer	Exducer	Trim
Supercore	PN							
	851285-5011S	76mm	109mm	49	0.88	93mm	84mm	82
	851285-5012S	80mm	109mm	54	0.88	93mm	84mm	82
Turbine Kits: GTX47		PN		A/R	Inlet	Outlet	Wastegate	Divided
Free Float		761208-0010		1.08	T6	V-Band	External	N
		761208-0011		1.23	T6	V-Band	External	N

Garrett GTX4720R GEN II

Horsepower: 1025 - 1950
Displacement: 2.5L - 10.0L

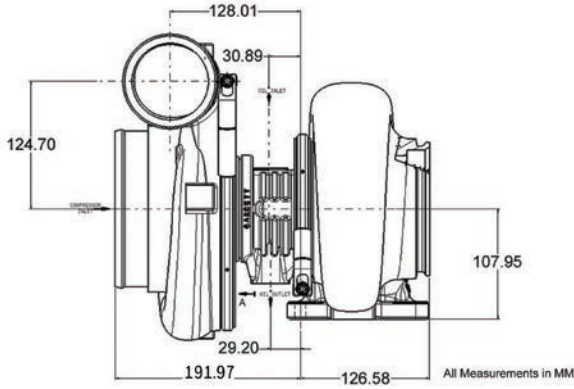

COMPRESSOR MAP

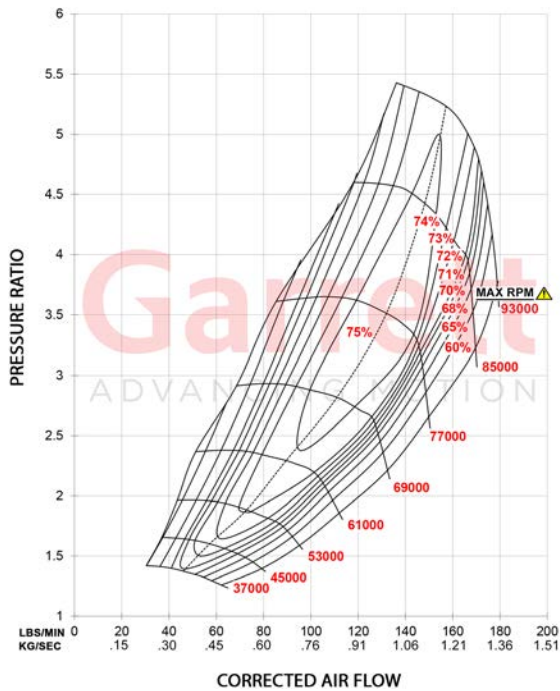

FEATURES:

- ◆ GEN 2 COMPRESSOR WHEEL AERODYNAMICS
- ◆ 9% INCREASED COMPRESSOR FLOW
- ◆ 76MM, 80MM, 88MM INDUCER CONFIGURATIONS
- ◆ .88 A/R COMPRESSOR HOUSING VOLUTE
- ◆ 30% LOWER INERTIA THAN PREVIOUS GENERATION
- ◆ SUPERCORE AND TURBINE HOUSING SOLD SEPARATELY
- ◆ COMPATIBLE WITH GT AND GTX GEN I TURBINE HOUSINGS

EXHAUST FLOW CHART

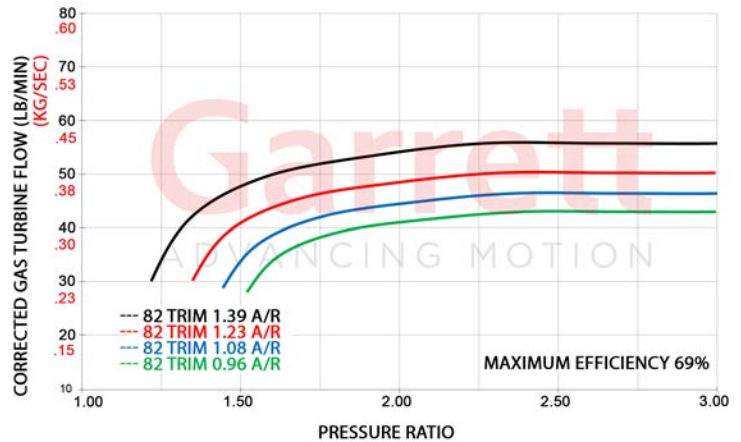

GTX4720R Gen II		Compressor				Turbine		
HP: 1025-1950	Disp: 2.5L-10.0L	Inducer	Exducer	Trim	A/R	Inducer	Exducer	Trim
Supercore		PN						
	851285-5013S	76mm	120mm	41	0.88	93mm	84mm	82
	851285-5014S	80mm	120mm	45	0.88	93mm	84mm	82
	851285-5015S	88mm	120mm	54	0.88	93mm	84mm	82
Turbine Kits: GTX47		PN				Outlet	Wastegate	Divided
Free Float		761208-0010		1.08	T6	V-Band	External	N
		761208-0011		1.23	T6	V-Band	External	N

Garrett GTX5009R GEN II

Horsepower: 875 - 1700
Displacement: 2.5L - 10.0L

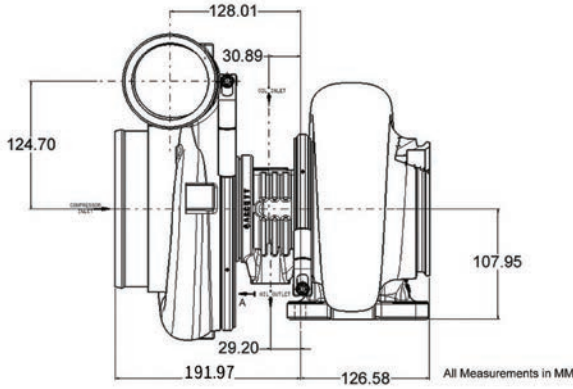

COMPRESSOR MAP

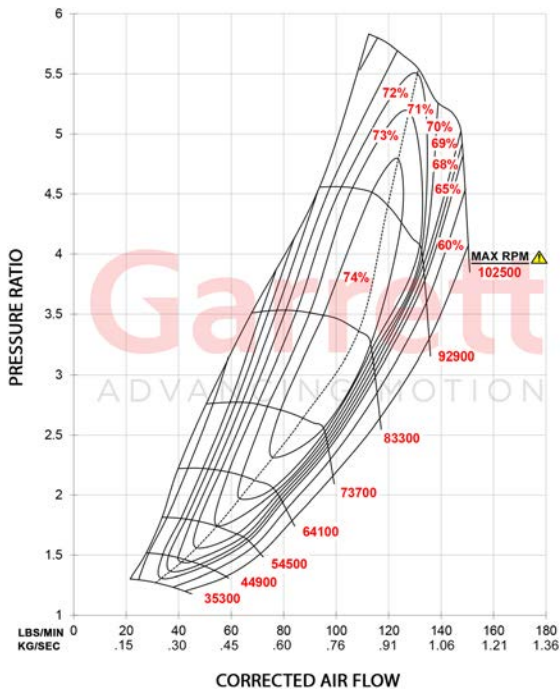

FEATURES:

- ◆ GEN 2 COMPRESSOR WHEEL AERODYNAMICS
- ◆ 15% INCREASED COMPRESSOR FLOW
- ◆ 76MM, 80MM, INDUCER CONFIGURATIONS
- ◆ .88 A/R COMPRESSOR HOUSING VOLUTE
- ◆ 39% LOWER INERTIA THAN PREVIOUS GENERATION
- ◆ SUPERCORE AND TURBINE HOUSING SOLD SEPARATELY
- ◆ COMPATIBLE WITH GT AND GTX GEN I TURBINE HOUSINGS

EXHAUST FLOW CHART

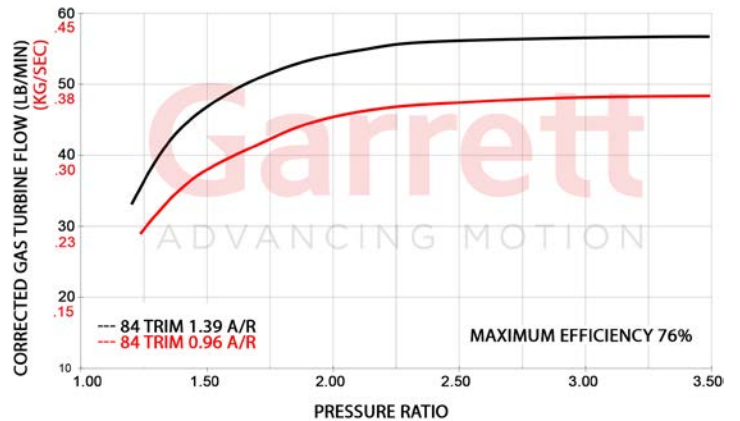

GTX5009R Gen II		Compressor				Turbine		
HP: 875-1700	Disp: 2.5L-10.0L	Inducer	Exducer	Trim	A/R	Inducer	Exducer	Trim
Supercore	PN							
	851285-5016S	76mm	109mm	49	0.88	99mm	91mm	84
	851285-5017S	80mm	109mm	54	0.88	99mm	91mm	84
Turbine Kits: GTX50		PN		A/R	Inlet	Outlet	Wastegate	Divided
Free Float		761208-0030		0.96	T6	V-Band	External	N
		761208-0032		1.23	T6	V-Band	External	N
		761208-0033		1.39	T6	V-Band	External	N

Garrett GTX5020R GEN II

Horsepower: 1075 - 2050
 Displacement: 2.8L - 11.0L

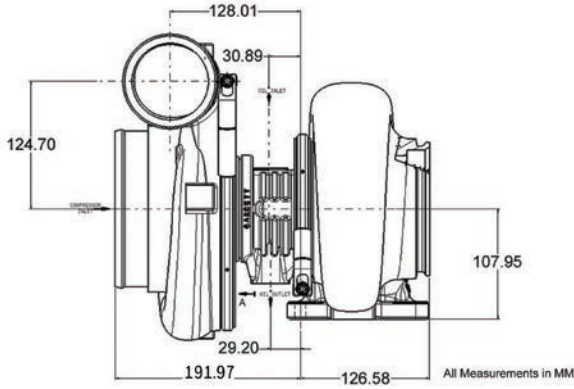

COMPRESSOR MAP

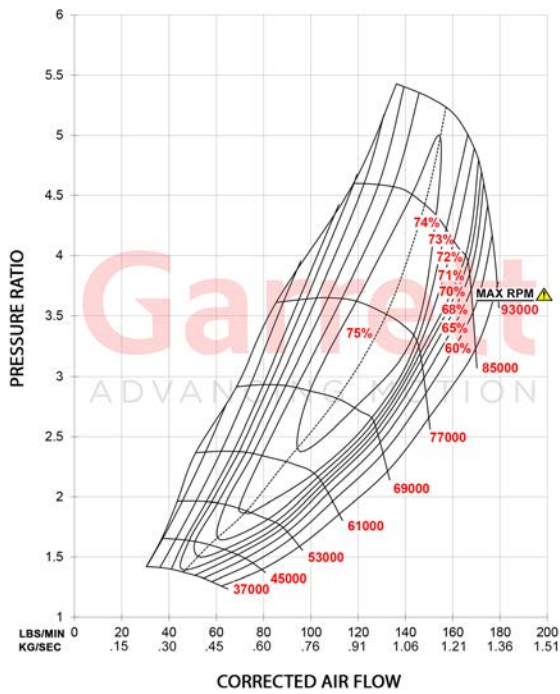

FEATURES:

- ◆ GEN 2 COMPRESSOR WHEEL AERODYNAMICS
- ◆ 9% INCREASED COMPRESSOR FLOW
- ◆ 76MM, 80MM, 88MM INDUCER CONFIGURATIONS
- ◆ .88 A/R COMPRESSOR HOUSING VOLUTE
- ◆ 30% LOWER INERTIA THAN PREVIOUS GENERATION
- ◆ SUPERCORE AND TURBINE HOUSING SOLD SEPARATELY
- ◆ COMPATIBLE WITH GT AND GTX GEN I TURBINE HOUSINGS

EXHAUST FLOW CHART

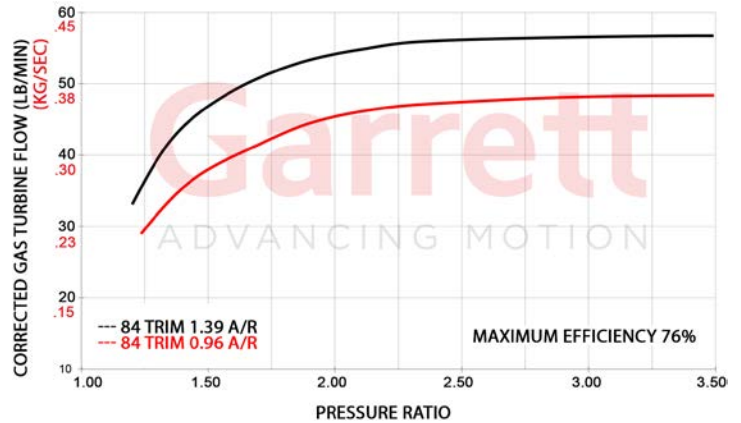

GTX5020R Gen II		Compressor				Turbine		
HP: 1075-2050	Disp: 2.8L-11.0L	Inducer	Exducer	Trim	A/R	Inducer	Turbine Exducer	Trim
Supercore	PN							
	851285-5018S	76mm	120mm	41	0.88	99mm	91mm	84
	851285-5019S	80mm	120mm	45	0.88	99mm	91mm	84
	851285-5020S	88mm	120mm	54	0.88	99mm	91mm	84
Turbine Kits: GTX50		PN		A/R	Inlet	Outlet	Wastegate	Divided
Free Float		761208-0030		0.96	T6	V-Band	External	N
		761208-0032		1.23	T6	V-Band	External	N
		761208-0033		1.39	T6	V-Band	External	N

Garrett GTX5533R GEN II

Horsepower: 1000- 2500
Displacement: 3.0L - 12.0L

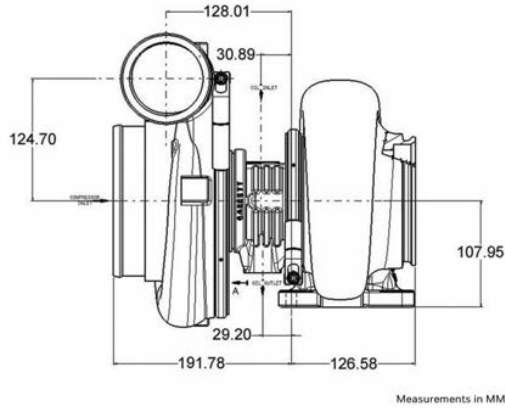

COMPRESSOR MAP

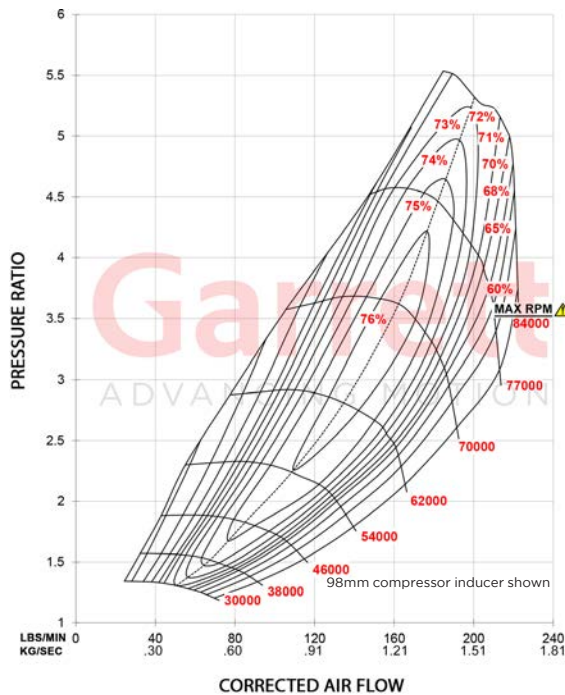

FEATURES:

- ◆ GEN 2 AERODYNAMICS FEATURE INCREASED HORSEPOWER RANGE
- ◆ NEW FULLY-MACHINED SPEED SENSOR PORT
- ◆ IMPROVED PORTED SHROUD DESIGN FOR SURGE RESISTANCE
- ◆ LIGHTWEIGHT BILLET BACKPLATE
- ◆ V-BAND COMPRESSOR OUTLET CONFIGURATION
- ◆ T6 AND V-BAND TURBINE HOUSING INLET OPTIONS

EXHAUST FLOW CHART

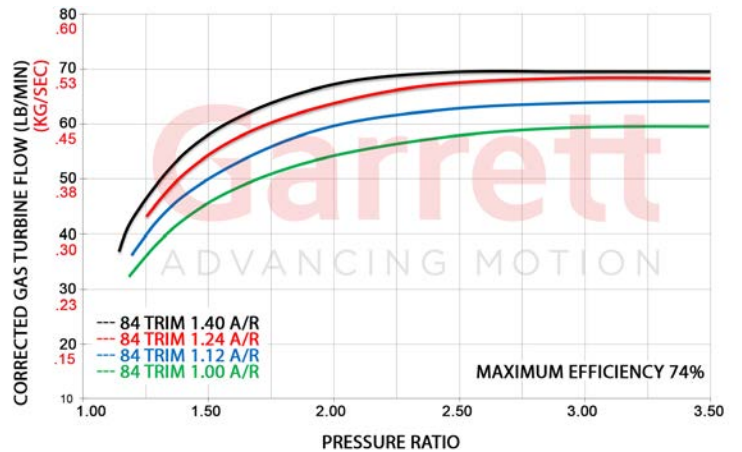

GTX5533R Gen II		Compressor				Turbine		
HP:1000-2500	Disp: 3.0L-12.0L	Inducer	Exducer	Trim	A/R	Inducer	Exducer	Trim
Supercore	PN							
	851285-5001S	85mm	133mm	41	0.88	112mm	102mm	84
	851285-5002S	88mm	133mm	44	0.88	112mm	102mm	84
	851285-5003S	91mm	133mm	47	0.96	112mm	102mm	84
	851285-5004S	94mm	133mm	50	0.96	112mm	102mm	84
	851285-5005S	98mm	133mm	54	0.96	112mm	102mm	84
Turbine Kits: GTX55								
* Long outlet with cross bolts								
	*761208-0062			1.24	V-Band	V-Band	External	N
	*761208-0063			1.40	V-Band	V-Band	External	N
	761208-0064			1.24	V-Band	V-Band	External	N
	761208-0065			1.40	V-Band	V-Band	External	N
	761208-0015			1.12	T6	V-Band	External	N
	761208-0025			1.24	T6	V-Band	External	N
	761208-0017			1.40	T6	V-Band	External	N

Garrett GTX5544R GEN II

Horsepower: 1400- 2850
Displacement: 3.0L - 12.0L

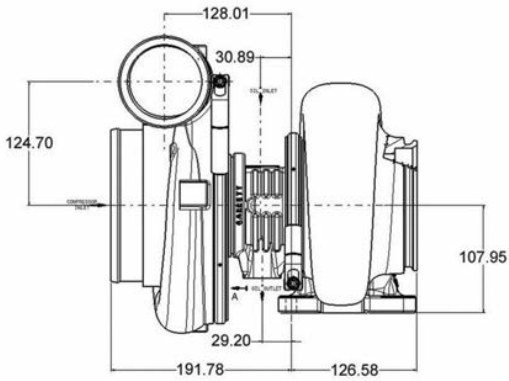

Measurements in MM



COMPRESSOR MAP

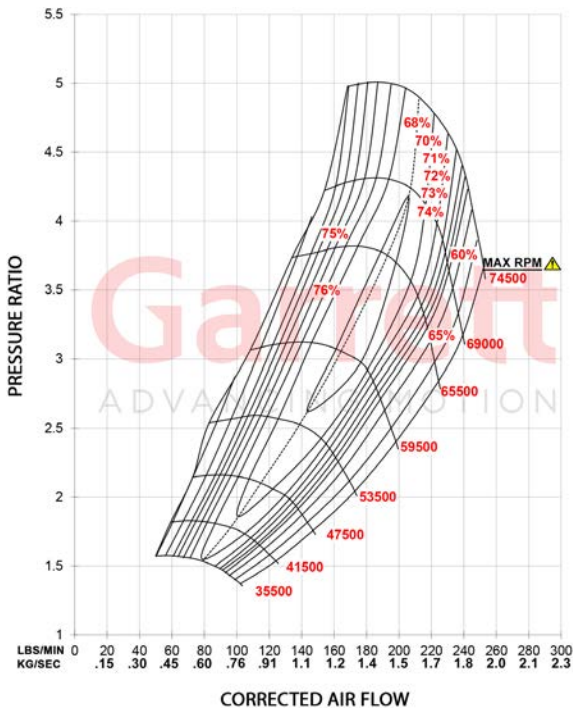

FEATURES:

- ◆ GEN 2 COMPRESSOR WHEEL AERODYNAMICS
- ◆ LIGHTWEIGHT BILLET BACKPLATE
- ◆ (NEW) BACKPLATE TO COMPRESSOR HOUSING O-RING
- ◆ 144MM COMPRESSOR EXDUCER
- ◆ FEATURES THE .96 A/R COMPRESSOR HOUSING
- ◆ SUPERCORE AND TURBINE HOUSING SOLD SEPARATELY
- ◆ COMPATIBLE WITH GT, GTX, AND GTX5533R TURBINE HOUSINGS

EXHAUST FLOW CHART

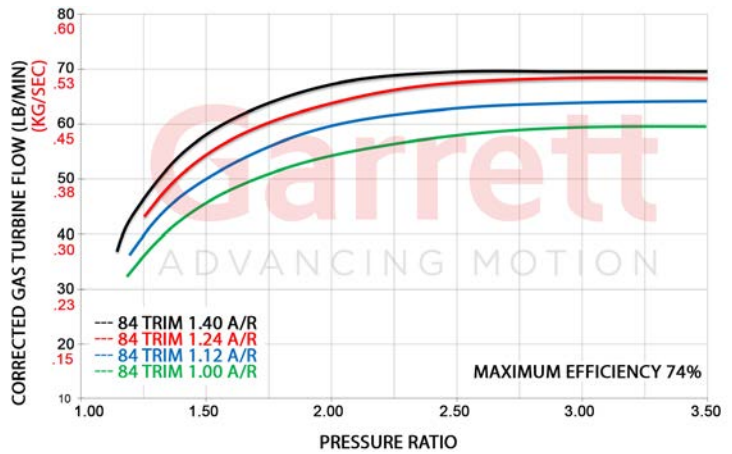

GTX5544R Gen II		Compressor				Turbine			
HP:1400-2850	Disp: 3.0L-12.0L	Inducer	Exducer	Trim	A/R	Inducer	Exducer	Trim	
Supercore		PN							
851285-5021S		102mm	144mm	50	0.96	112mm	102mm	84	
851285-5022S		106mm	144mm	54	0.96	112mm	102mm	84	
Turbine Kits: GTX55		PN			A/R	Inlet	Outlet	Wastegate	Divided
* Long outlet with cross bolts		*761208-0062		1.24	V-Band	V-Band	External	N	
		*761208-0063		1.40	V-Band	V-Band	External	N	
		761208-0064		1.24	V-Band	V-Band	External	N	
		761208-0065		1.40	V-Band	V-Band	External	N	
		761208-0015		1.12	T6	V-Band	External	N	
		761208-0025		1.24	T6	V-Band	External	N	
		761208-0017		1.40	T6	V-Band	External	N	



GTX5533R GEN II

Horsepower: 1000- 2500
Displacement: 3.0L - 12.0L

Comp: 85mm, 88mm, 91mm, 94mm, 98mm



GTX5544R GEN II

Horsepower: 1400- 2850
Displacement: 3.0L - 12.0L

Comp: 102mm, 106mm

FEATURES:

- ◆ GEN II AERODYNAMICS FEATURE INCREASED HORSEPOWER RANGE
- ◆ NEW FULLY MACHINED SPEED SENSOR PORT
- ◆ IMPROVED PORTED SHROUD DESIGN FOR SURGE RESISTANCE
- ◆ LIGHTWEIGHT BILLET BACKPLATE
- ◆ V-BAND COMPRESSOR OUTLET CONFIGURATION
- ◆ AVAILABLE IN 85MM, 88MM, 91MM, 94MM, 98MM, 102MM, 106MM

GTX55 STAINLESS STEEL TURBINE HOUSING CONFIGURATIONS



FEATURES:

- ◆ 1.24 A/R AND 1.40 A/R OPTIONS
- ◆ 3/8" GRADE 5 CROSS BOLTS ON LONG OUTLET HOUSINGS
- ◆ THREADED BOSSES FOR ATTACHMENT POINTS
- ◆ 4.25" V-BAND INLET | 5" V-BAND OUTLET
- ◆ COMPATIBLE WITH GTX5533R GEN I & GEN II | GTX5544R
- ◆ LONG AND SHORT OUTLET CONFIGURATIONS

GTX55 Turbine Kit PN	Desc	A/R	Inlet	Outlet
761208-0062	Long Outlet	1.24	V-Band	V-Band
761208-0064	Short Outlet	1.24	V-Band	V-Band
761208-0063	Long Outlet	1.40	V-Band	V-Band
761208-0065	Short Outlet	1.40	V-Band	V-Band

GARRETT BOOST | CLUB LINE

Garrett Boost | Club Line turbochargers are high performance journal bearing products at a cost effective price range. GBC combines modern, high flowing aerodynamics with a robust journal bearing rotating group to make a powerful and affordable turbocharger.



THE REPLACEMENT FOR **SMALL** DISPLACEMENT



Product Features	GBC14-200	GBC17-250	GBC20-300	GBC22-350	GBC35-700	GBC37-900
Displacement Range	0.4L-1.0L	0.6L-1.5L	0.8L-2.0L	1.0L-2.5L	2.0L-5.0L	2.0L-5.5L
Horsepower Range	140-200	150-250	170-300	200-350	400-700	450-900
Standard Rotation	•	•	•	•	•	•
Internally Wastegated	•	•	•	•		
Aluminum Backplate					•	•
Oil Cooled	•	•	•	•	•	•
Journal Bearing	•	•	•	•	•	•
Machined Pressure Port	•	•	•	•	•	•
Ported Shroud					•	•
T25 Inlet Turbine Housing		•	•	•		
T3 Inlet Turbine Housing					•	•
T4 Inlet Turbine Housing					•	•
T4 Divided Inlet Turbine Housing					•	•
3-Bolt Inlet Turbine Housing	•					
Inconel Turbine Wheel	•	•	•	•	•	•
Outline Interchangeable		•	•	•		
Outline Interchangeable					•	•

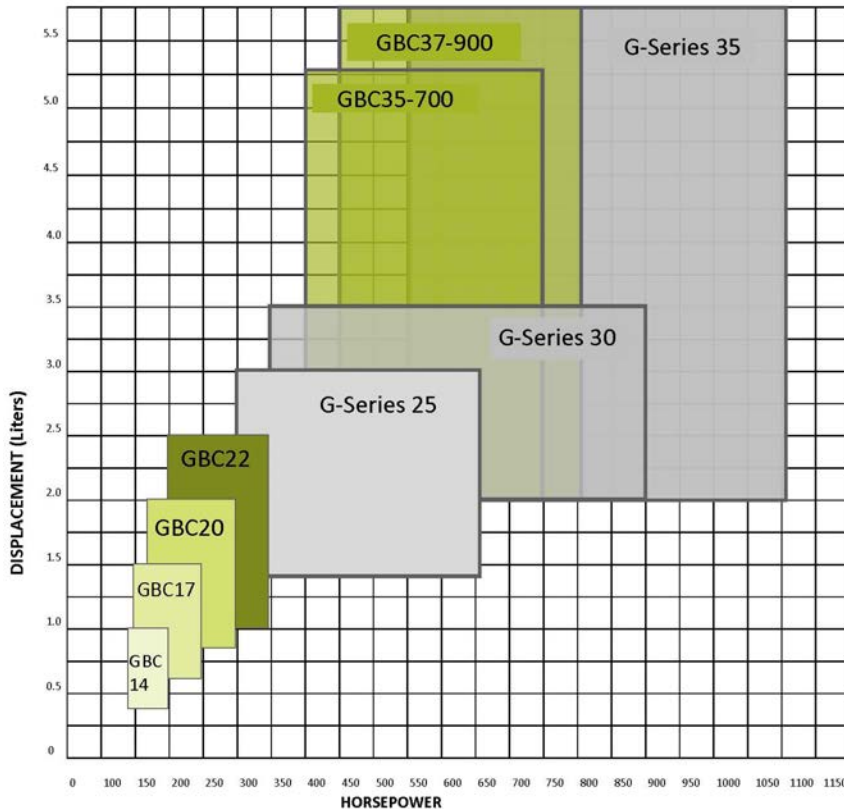

GARRETT BOOST | CLUB LINE FEATURES

- FRAME SIZES => 14, 17, 20, 22, 35, 37
- GBC (17|20|22) & (35|37) ARE OUTLINE INTERCHANGEABLE
- 150 - 900 HORSEPOWER CAPABILITY
- INTEGRATED WASTEGATE ASSEMBLY WITH CALIBRATED ACTUATOR (14|17|20|22)
- BILLET COMPRESSOR WHEEL WITH EXTENDED TIP DESIGN FOR HIGHER PRESSURE RATIO CAPABILITY
- GTX GEN II COMPRESSOR AERODYNAMICS
- MODERN TURBINE WHEEL AERODYNAMICS
- INCONEL TURBINE WHEEL MATERIAL
- DUCTILE IRON (SIMO+) TURBINE HOUSING MATERIAL
- JOURNAL BEARING ROTATING GROUP WITH 360-DEGREE THRUST BEARING
- OIL-COOLED CENTER HOUSING
- MACHINED BOOST SIGNAL PORT WITH INSTALLED PLUG

Garrett GBC14-200

Horsepower: 140 - 200
Displacement: 0.4L - 1.0L

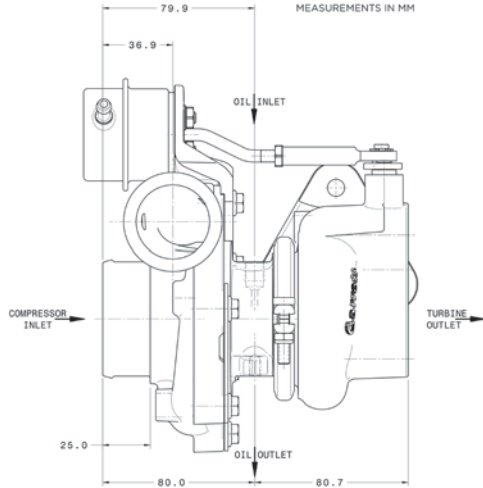

COMPRESSOR MAP

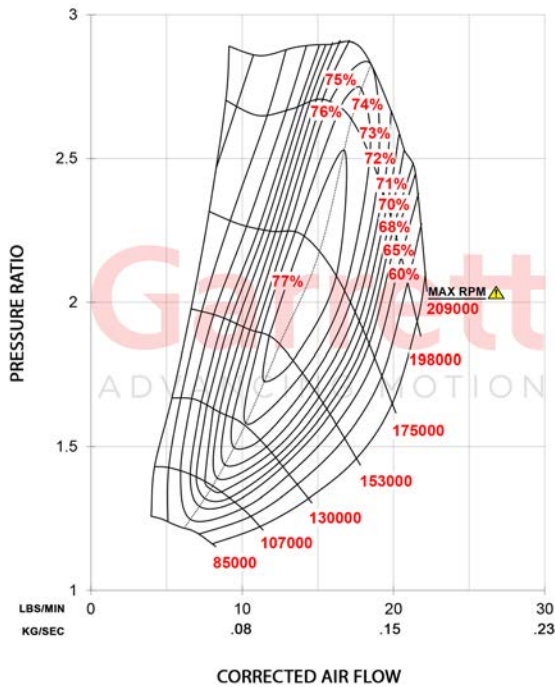

FEATURES:

- ◆ 34MM COMPRESSOR INDUCER
- ◆ SUPPORTS UP TO 200 HORSEPOWER
- ◆ FORGED FULLY-MACHINED COMPRESSOR WHEEL
- ◆ JOURNAL BEARING ROTATING GROUP
- ◆ INTERNALLY WASTEGATED TURBINE HOUSING
- ◆ ENGINEERED FOR SMALL DISPLACEMENT ENGINES INCLUDING POWERSPORTS, PERSONAL WATERCRAFT AND AUTOMOBILES

EXHAUST FLOW CHART

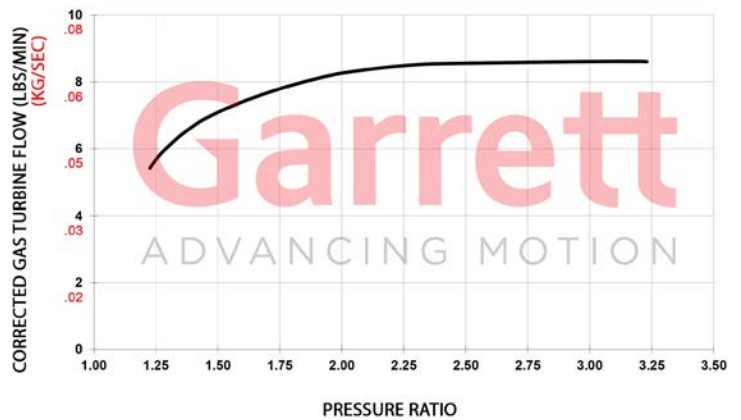

GBC14-200		Compressor			Turbine			
HP: 140-200	Disp: 0.4L-1.0L	Inducer	Exducer	A/R	Inducer	Exducer	Trim	A/R
Turbo PN: 896051-5004S		34mm	46mm	0.52	39mm	36mm	84	0.45

Garrett GBC17-250

Horsepower: 150 - 250

Displacement: 0.6L - 1.5L

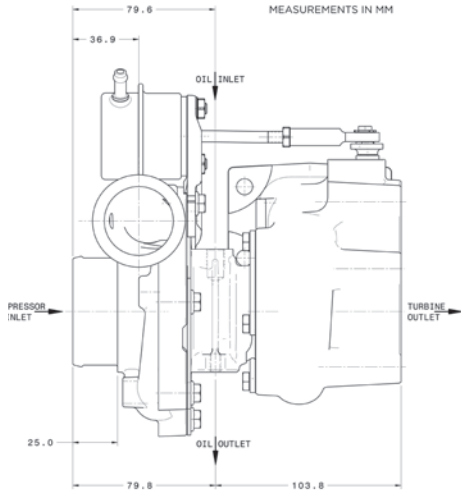

COMPRESSOR MAP

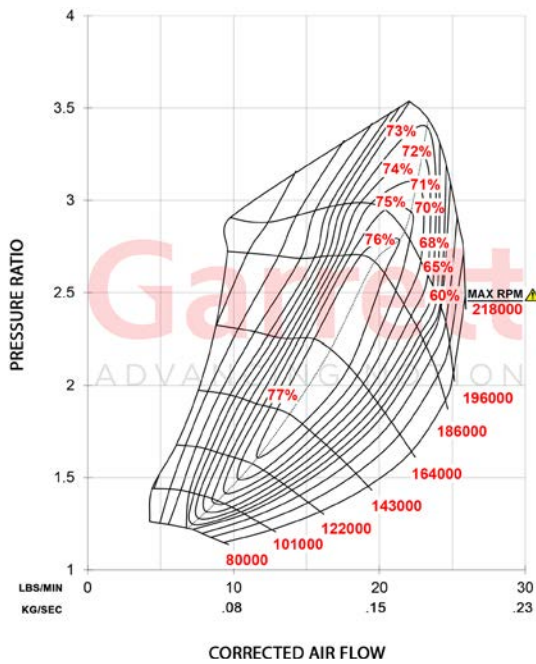

FEATURES:

- ◆ 36MM COMPRESSOR INDUCER
- ◆ SUPPORTS UP TO 250 HORSEPOWER
- ◆ FORGED FULLY-MACHINED COMPRESSOR WHEEL
- ◆ JOURNAL BEARING ROTATING GROUP
- ◆ INTERNALLY WASTEGATED TURBINE HOUSING
- ◆ ENGINEERED FOR SMALL DISPLACEMENT ENGINES INCLUDING POWERSPORTS, PERSONAL WATERCRAFT AND AUTOMOBILES

EXHAUST FLOW CHART

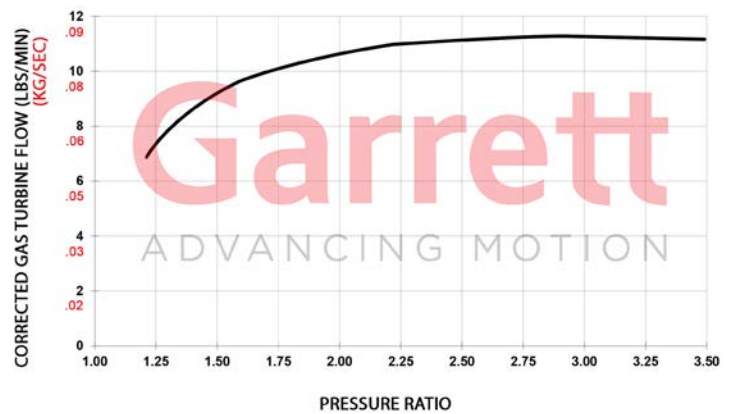

GBC17-250		Compressor			Turbine			
HP: 150-250	Disp: 0.6L-1.5L	Inducer	Exducer	A/R	Inducer	Exducer	Trim	A/R
Turbo PN: 896052-5003S		36mm	49mm	0.52	44mm	40mm	80	0.5

Garrett GBC20-300

Horsepower: 170 - 300
Displacement: 0.8L - 2.0L

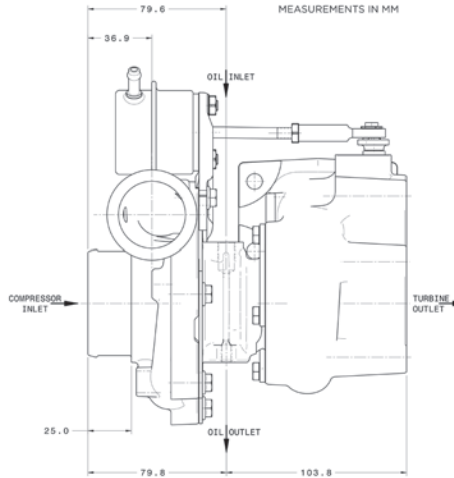

COMPRESSOR MAP

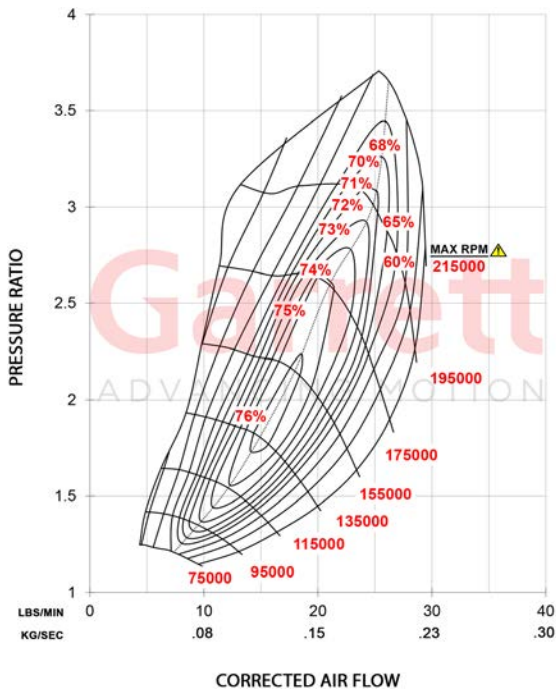

FEATURES:

- ◆ 39MM COMPRESSOR INDUCER
- ◆ SUPPORTS UP TO 300 HORSEPOWER
- ◆ FORGED FULLY-MACHINED COMPRESSOR WHEEL
- ◆ JOURNAL BEARING ROTATING GROUP
- ◆ INTERNALLY WASTEGATED TURBINE HOUSING
- ◆ ENGINEERED FOR SMALL DISPLACEMENT ENGINES INCLUDING POWERSPORTS, PERSONAL WATERCRAFT AND AUTOMOBILES

EXHAUST FLOW CHART

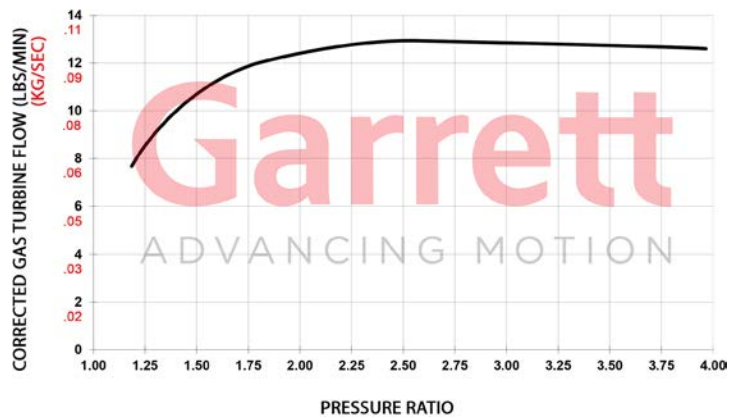

GBC20-300		Compressor			Turbine			
HP: 170-300	Disp: 0.8L-2.0L	Inducer	Exducer	A/R	Inducer	Exducer	Trim	A/R
Turbo PN: 896053-5003S		39mm	52mm	0.59	47mm	42mm	84	0.55

Garrett GBC22-350

Horsepower: 200 - 350
 Displacement: 1.0L - 2.5L

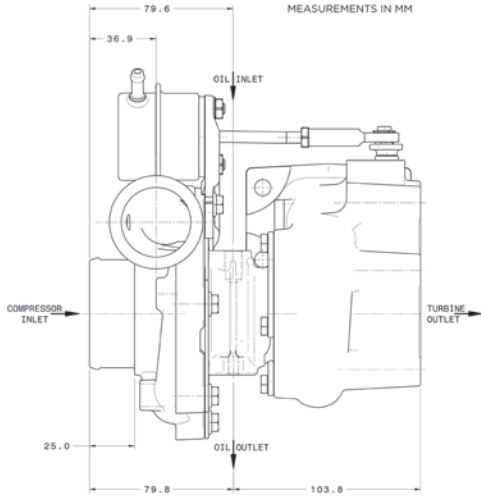

COMPRESSOR MAP

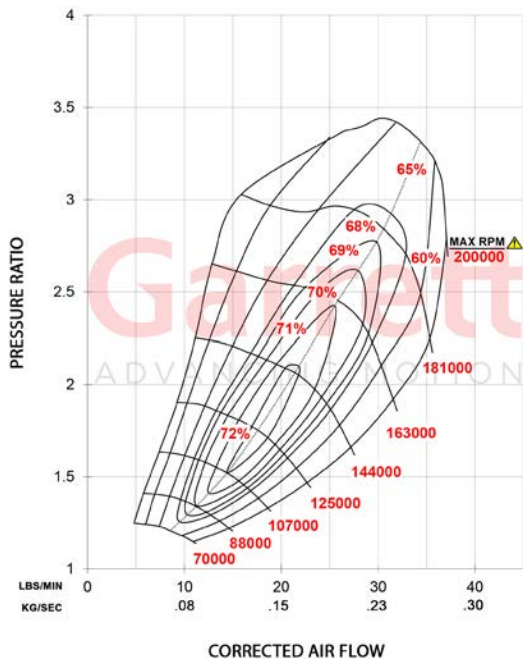

FEATURES:

- ◆ 44MM COMPRESSOR INDUCER
- ◆ SUPPORTS UP TO 350 HORSEPOWER
- ◆ FORGED FULLY-MACHINED COMPRESSOR WHEEL
- ◆ JOURNAL BEARING ROTATING GROUP
- ◆ INTERNALLY WASTEGATED TURBINE HOUSING
- ◆ ENGINEERED FOR SMALL DISPLACEMENT ENGINES INCLUDING POWERSPORTS, PERSONAL WATERCRAFT AND AUTOMOBILES

EXHAUST FLOW CHART

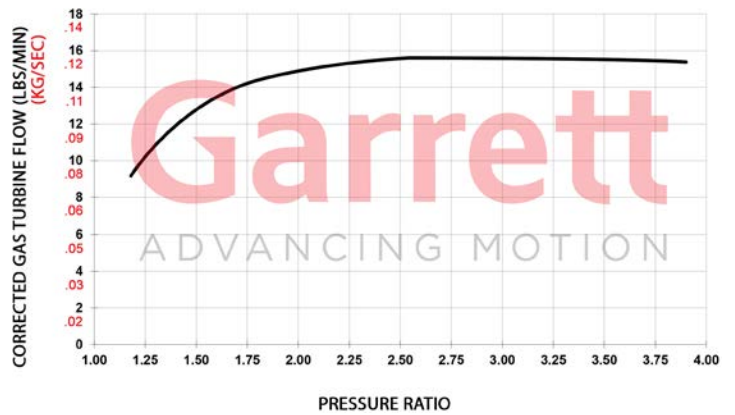

GBC22-350		Compressor			Turbine			
HP: 200-350	Disp: 1.0L-2.5L	Inducer	Exducer	A/R	Inducer	Exducer	Trim	A/R
Turbo PN: 896055-5003S		44mm	56mm	0.59	50mm	46mm	84	0.64

Garrett GBC35-700

Horsepower: 400 - 700
Displacement: 2.0L - 5.0L

Garrett

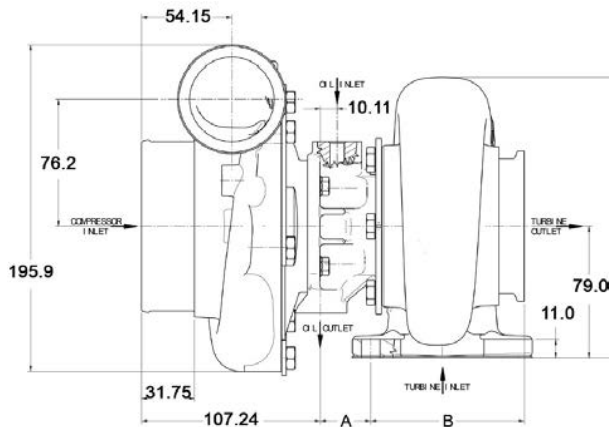

COMPRESSOR MAP

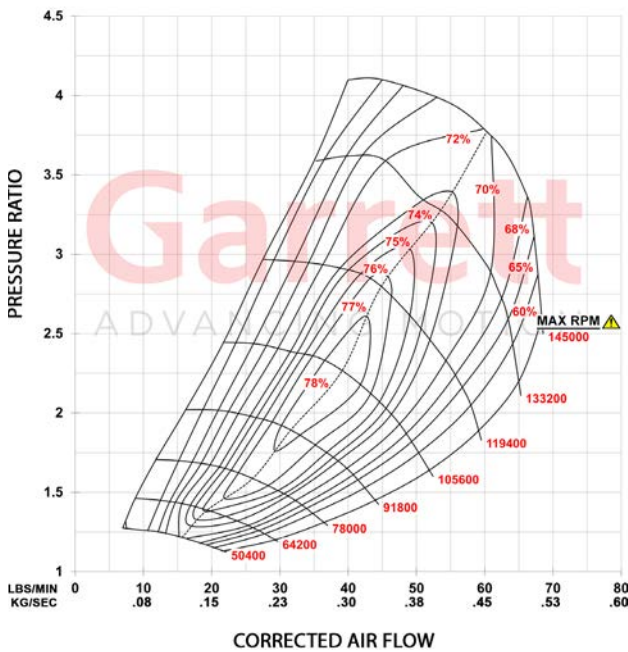

FEATURES:

- ◆ 58MM COMPRESSOR INDUCER | 76MM COMPRESSOR EXDUCER
- ◆ BILLET COMPRESSOR WHEEL WITH EXTENDED TIP DESIGN FOR HIGHER PRESSURE RATIOS
- ◆ JOURNAL BEARING WITH 360-DEGREE THRUST BEARING
- ◆ OUTLINE INTERCHANGEABLE WITH GBC37-900
- ◆ MACHINED BOOST SIGNAL PORT WITH INSTALLED PLUG
- ◆ MODERN TURBINE WHEEL AERODYNAMICS
- ◆ OIL-COOLED CENTER HOUSING

EXHAUST FLOW CHART

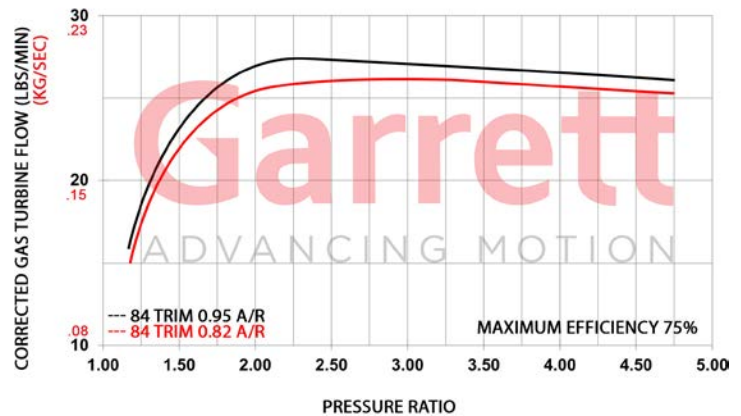

GBC35-700		Compressor				Turbine		
		Inducer	Exducer	Trim	A/R	Inducer	Exducer	Trim
HP: 400-700	Disp: 2.0L-5.0L	58mm	76mm	58	0.72	68mm	62mm	84
Supercore		PN						
		913840-5001S						
Turbine Kits: GBC35		PN	A/R	Inlet	Outlet	Wastegate	Divided	
Free Float		740902-0123	0.82	T3	V-Band	External	N	
		740902-0124	0.82	T4	V-Band	External	N	
		740902-0125	0.95	T4	V-Band	External	Y	

Garrett GBC37-900

Garrett

Horsepower: 450 - 900
Displacement: 2.0L - 5.5L

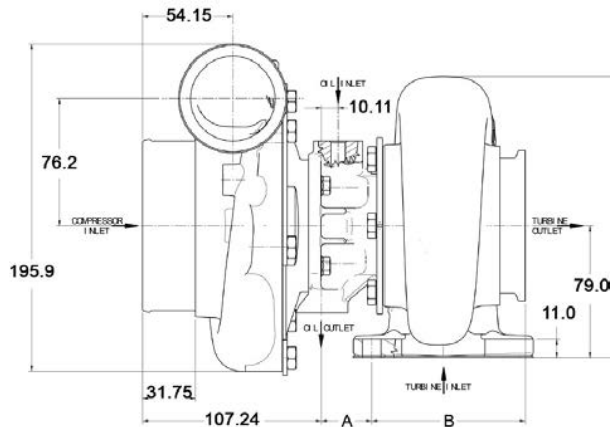

COMPRESSOR MAP

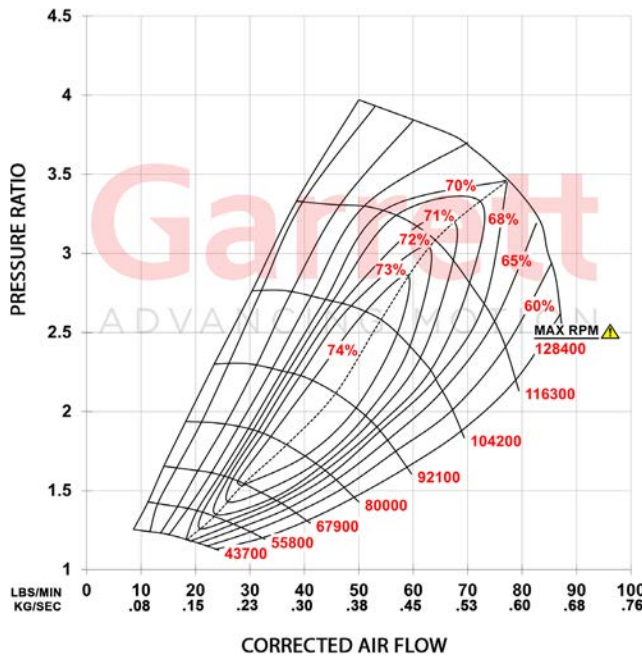

FEATURES:

- ◆ 67MM COMPRESSOR INDUCER | 84MM COMPRESSOR EXDUCER
- ◆ BILLET COMPRESSOR WHEEL WITH EXTENDED TIP DESIGN FOR HIGHER PRESSURE RATIOS
- ◆ JOURNAL BEARING WITH 360-DEGREE THRUST BEARING
- ◆ OUTLINE INTERCHANGEABLE WITH GBC37-900
- ◆ MACHINED BOOST SIGNAL PORT WITH INSTALLED PLUG
- ◆ MODERN TURBINE WHEEL AERODYNAMICS
- ◆ OIL-COOLED CENTER HOUSING

EXHAUST FLOW CHART

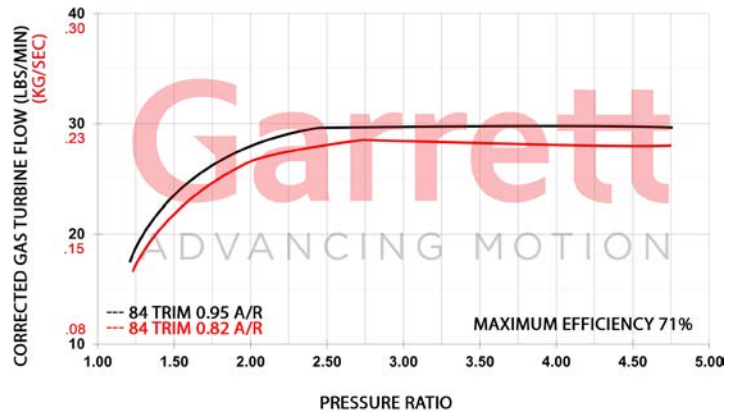

GBC37-900	Compressor				Turbine			
	HP: 450-900	Disp: 2.0L-5.5L	Inducer 67mm	Exducer 84mm	Trim 64	A/R 0.72	Inducer 73mm	Exducer 65mm
Supercore		PN 913840-5002S						
Turbine Kits: GBC37		PN		A/R	Inlet	Outlet	Wastegate	Divided
Free Float		740902-0126		0.82	T3	V-Band	External	N
		740902-0127		0.82	T4	V-Band	External	N
		740902-0128		0.95	T4	V-Band	External	Y

GTW SERIES

GTW Series turbochargers were engineered to provide budget-minded enthusiasts with a high-performing mid frame product that is offered in ball bearing and journal bearing options. GTW combines popular compressor inducer sizes like 58mm | 62mm | 64mm | 67mm with slightly larger (than GTX) turbine wheel sizes.

Fully-machined aluminum compressor wheels with GTX Gen II aero provide optimal horsepower range and boost response for 2.0L - 6.0L engine displacements. A lightweight aluminum backplate comes standard on all GTW turbochargers and reduces overall weight.

The water cooled CHRA keeps housing temperatures to a minimum. The GTW3476 and GTW3884 turbine wheels are constructed from Inconel, a Super Alloy that maintains strength during prolonged exposure to high exhaust gas temperatures. Turbine kits are offered in open volute and twin scroll, and a variety of A/R and flange configurations. The GTW is a cost effective option for enthusiasts looking to turbocharge their vehicles.



Scott Birdsall | Garrett GTW3884R | Pikes Peak International Hill Climb



Alford

Garrett

128

ALFORD INC.

Garrett

Power Stroke

Garrett GTW3476R

Horsepower: 450 - 700
Displacement: 2.0L - 4.5L

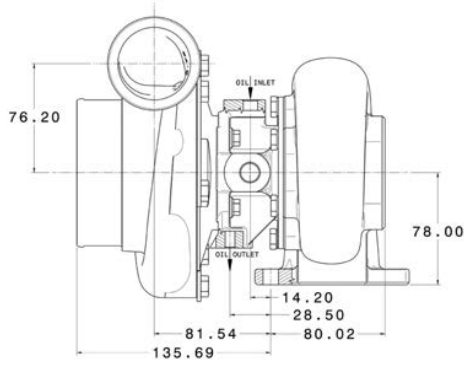

Measurements in MM



COMPRESSOR MAP

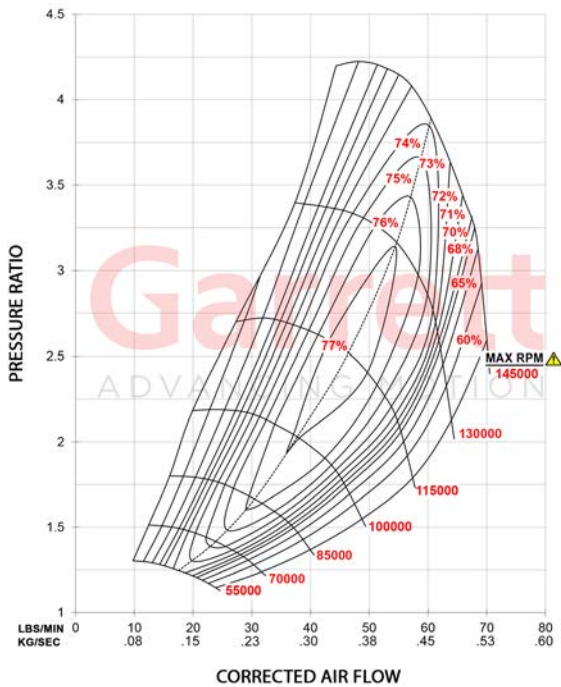

FEATURES:

- ◆ PORTED SHROUD DESIGN FOR SURGE RESISTANCE
- ◆ AVAILABLE IN BOTH JOURNAL BEARING AND BALL BEARING OPTIONS
- ◆ FORGED FULLY-MACHINED BILLET COMPRESSOR WHEEL
- ◆ LIGHTWEIGHT ALUMINUM BACKPLATE
- ◆ INCONEL SUPER-ALLOY TURBINE WHEEL

EXHAUST FLOW CHART

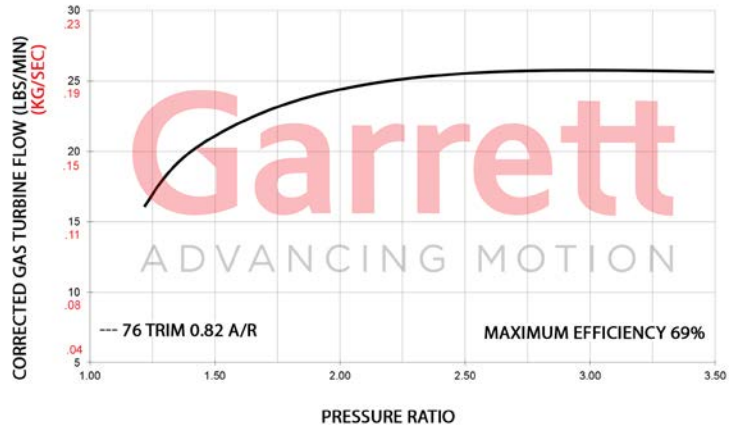

GTW3476R	Compressor				Turbine		
	Inducer	Exducer	Trim	A/R	Inducer	Exducer	Trim
HP: 450-700 Disp: 2.0L-4.5L	58mm	76mm	58	0.70	65mm	57mm	76
Supercore	PN						
Ball Bearing	841691-5001S						
Journal Bearing	841297-5001S						
Turbine Kits: GTW34	PN		A/R	Inlet	Outlet	Wastegate	Divided
Free Float	844669-0002		0.63	T3	4-Bolt	External	N
	844669-0003		0.82	T3	4-Bolt	External	N

Garrett GTW3684R

Horsepower: 425 - 750
Displacement: 2.0L - 5.3L

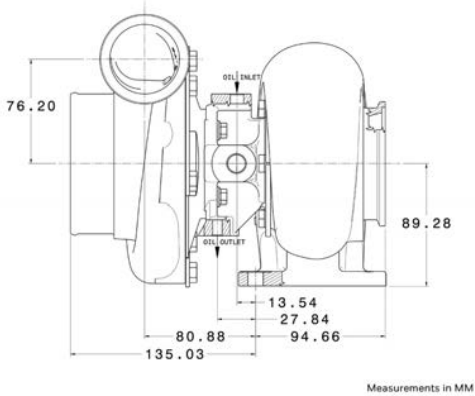

Measurements in MM



COMPRESSOR MAP

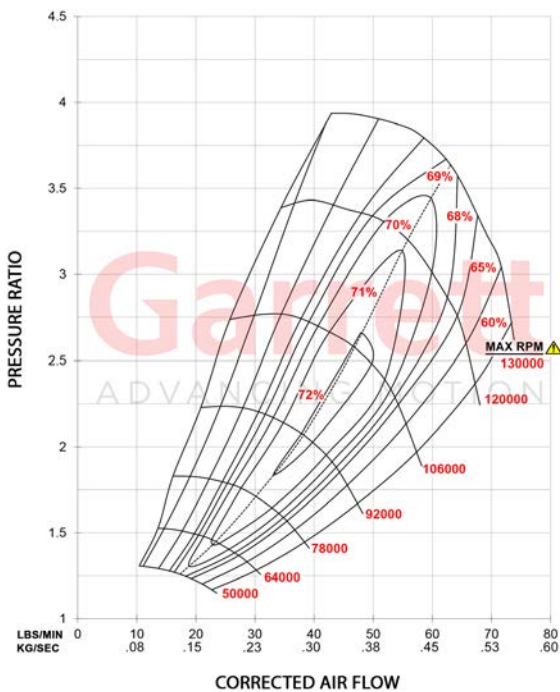

- FEATURES:**
- ◆ PORTED SHROUD DESIGN FOR SURGE RESISTANCE
 - ◆ AVAILABLE IN BOTH JOURNAL BEARING AND BALL BEARING OPTIONS
 - ◆ FORGED FULLY-MACHINED BILLET COMPRESSOR WHEEL
 - ◆ TURBINE HOUSINGS AVAILABLE IN DIVIDED CONFIGURATION
 - ◆ LIGHTWEIGHT ALUMINUM BACKPLATE

EXHAUST FLOW CHART

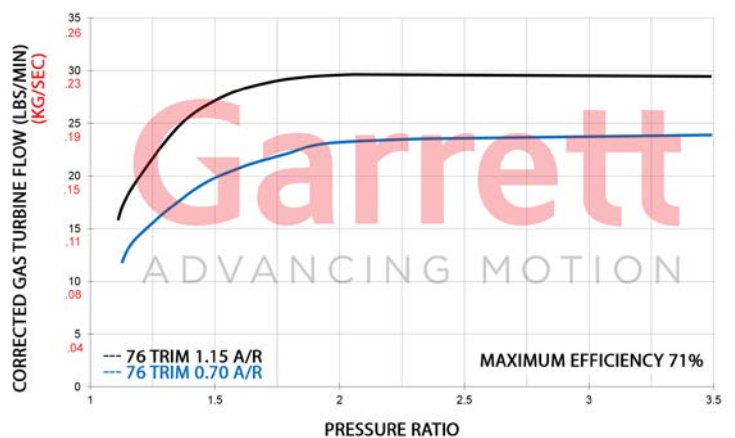

GTW3684R		Compressor				A/R	Turbine		
		Inducer	Exducer	Trim	A/R		Inducer	Exducer	Trim
HP: 425-750	Disp: 2.0L-5.3L	62mm	84mm	54	0.70	71mm	62mm	76	
Supercore		PN							
Ball Bearing		841691-5002S							
Journal Bearing		841297-5002S							
Turbine Kits: GTW36		PN		A/R	Inlet	Outlet	Wastegate	Divided	
Free Float		844669-0005		0.70	T4	V-Band	External	Y	
		844669-0007		1.15	T4	V-Band	External	Y	

Garrett GTW3884R

Horsepower: 450 - 950
Displacement: 2.0L - 6.0L

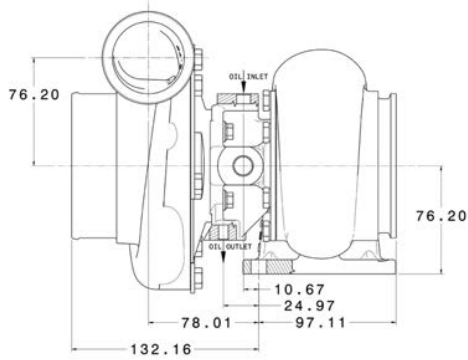

Measurements in MM



COMPRESSOR MAP

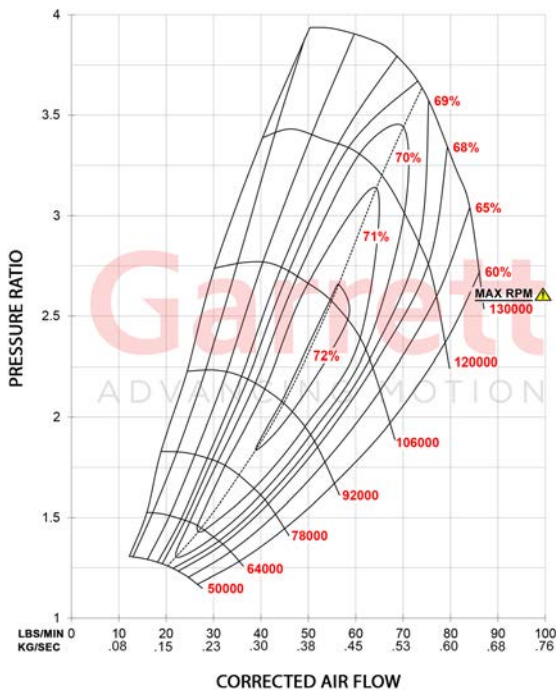

FEATURES:

- ◆ PORTED SHROUD DESIGN FOR SURGE RESISTANCE
- ◆ AVAILABLE IN JOURNAL BEARING OR BALL BEARING OPTIONS
- ◆ FORGED FULLY-MACHINED BILLET COMPRESSOR WHEEL
- ◆ INCONEL SUPER-ALLOY TURBINE WHEEL
- ◆ LIGHTWEIGHT ALUMINUM BACKPLATE

EXHAUST FLOW CHART

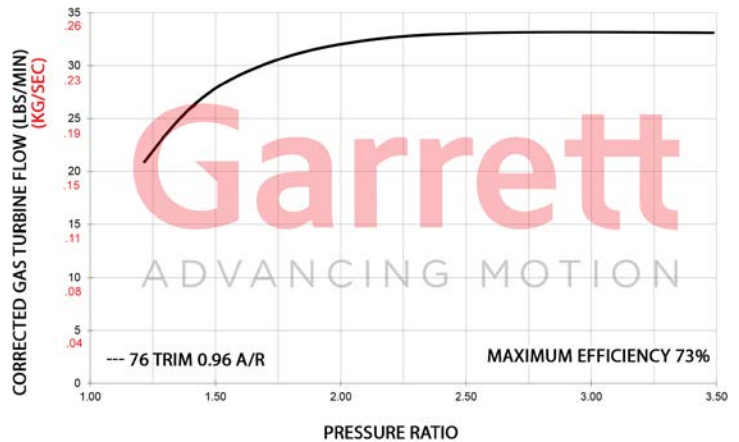

GTW3884R		Compressor				Turbine		
HP: 450-950	Disp: 2.0L-6.0L	Inducer	Exducer	Trim	A/R	Inducer	Exducer	Trim
Supercore	PN							
Ball Bearing	841691-5003S	62mm	84mm	54	0.70	74mm	65mm	76
Ball Bearing	841691-5004S	64mm	84mm	58	0.70	74mm	65mm	76
Ball Bearing	841691-5005S	67mm	84mm	64	0.70	74mm	65mm	76
Journal Bearing	841297-5003S	62mm	84mm	54	0.70	74mm	65mm	76
Journal Bearing	841297-5004S	64mm	84mm	58	0.70	74mm	65mm	76
Journal Bearing	841297-5005S	67mm	84mm	64	0.70	74mm	65mm	76
Turbine Kits: GTW38		PN	A/R	Inlet	Outlet	Wastegate	Divided	
Free Float		844669-0009	0.96	T4	V-Band	External	N	



GARRETT GEAR

BOOST APPAREL & CULTURE

GARRETTGEAR.COM

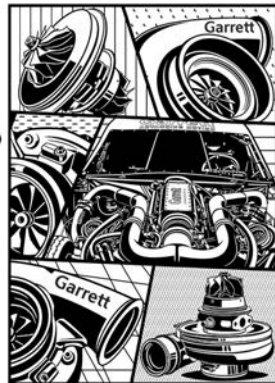

GT SERIES

Garrett GT Series is the name that pioneered turbo technology and boosted drag racing and road racing teams to break hundreds of world records. The GT Series lineup is offered in both journal and ball bearing options, with sizes ranging from GT2052 to GT3582.

The cast compressor wheels feature original GT Series aerodynamics and provide maximum durability and longevity. Internally wastegated turbine housing options are available in all GT Series sizes.

Turbine kits are offered in open volute and twin scroll, and a variety of A/R and flange configurations. For any performance need, GT Series turbochargers have you covered.





Garrett GT2052

Horsepower: 140 - 230
 Displacement: 1.4L - 2.0L

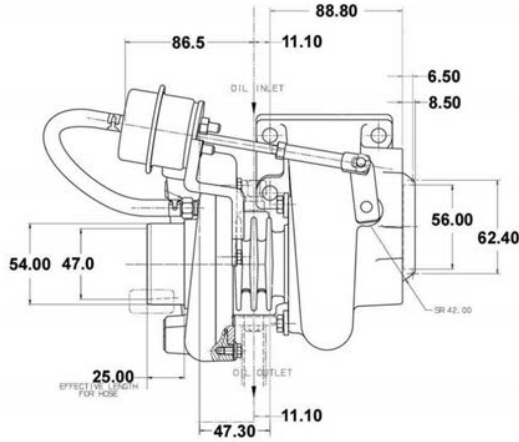

Measurements in MM



COMPRESSOR MAP

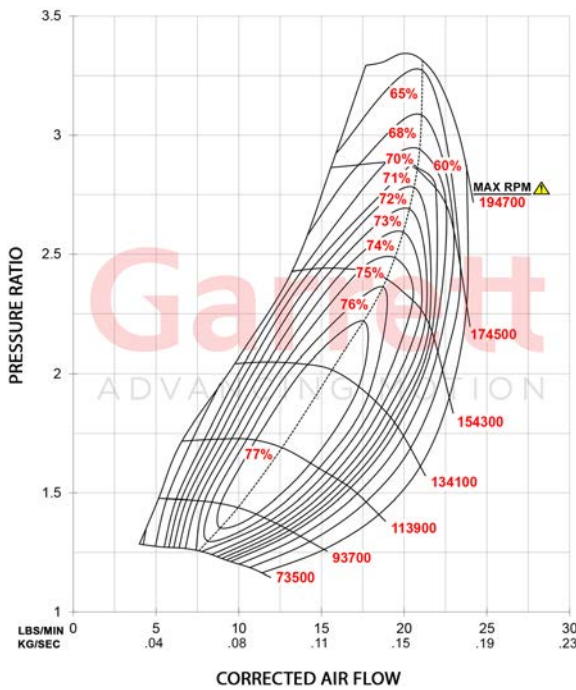

FEATURES:

- ◆ ORIGINAL GT SERIES AERODYNAMICS
- ◆ INTERNALLY WASTEGATED TURBINE HOUSING
- ◆ SOLD AS A COMPLETE TURBO (INCLUDES TURBINE KIT)
- ◆ JOURNAL BEARING CONFIGURATION
- ◆ OIL COOLED CHRA

EXHAUST FLOW CHART

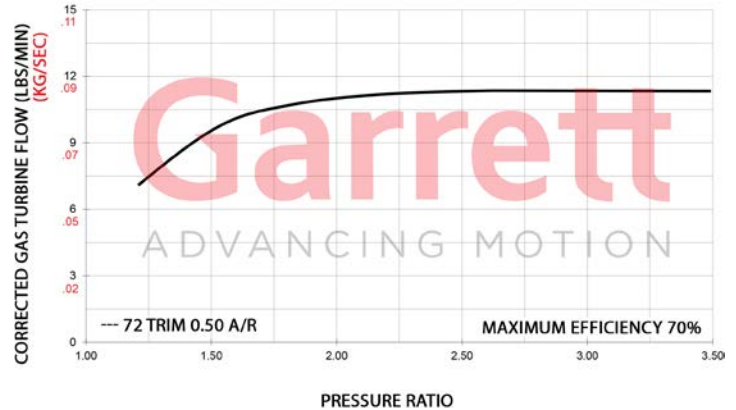

GT2052		Compressor			Turbine			
HP: 140-230	Disp: 1.4L-2.0L	Inducer	Exducer	A/R	Inducer	Exducer	Trim	A/R
Turbo PN: 727264-5001W		38mm	52mm	0.51	47mm	40mm	72	0.50

Garrett GT2252

Horsepower: 150 - 260
 Displacement: 1.7L - 2.5L

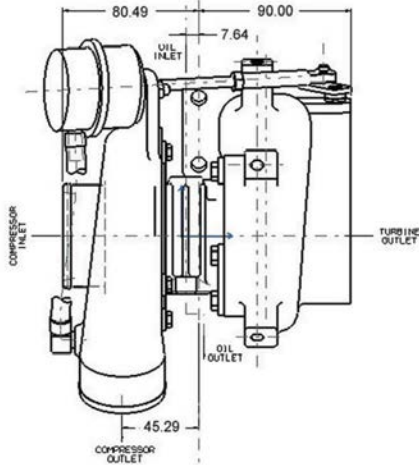

Measurements in MM



COMPRESSOR MAP

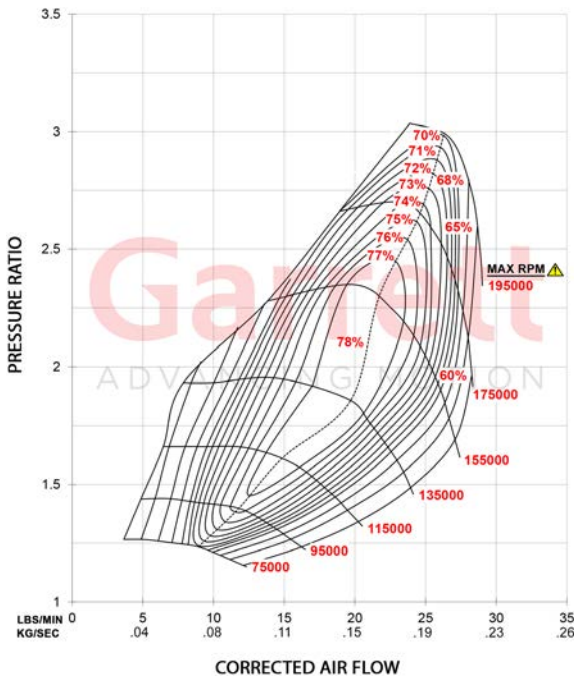

FEATURES:

- ◆ ORIGINAL GT SERIES AERODYNAMICS
- ◆ INTERNALLY WASTEGATED TURBINE HOUSING
- ◆ SOLD AS A COMPLETE TURBO (INCLUDES TURBINE KIT & ACTUATOR)
- ◆ JOURNAL BEARING CONFIGURATION
- ◆ OIL COOLED CHRA

EXHAUST FLOW CHART

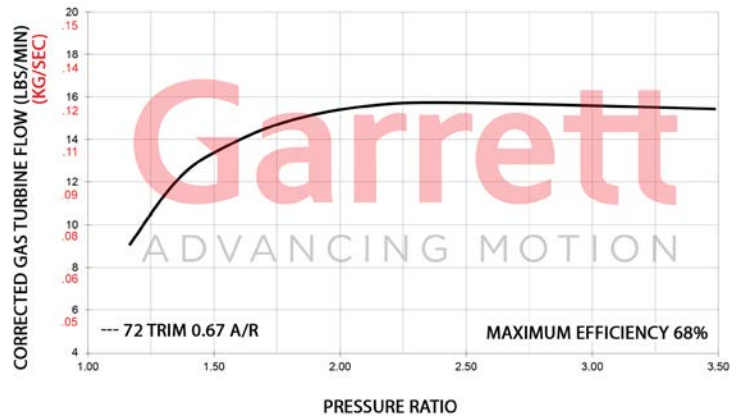

GT2252			Compressor			Turbine			
HP: 150-260	Disp: 1.7L-2.5L		Inducer	Exducer	A/R	Inducer	Exducer	Trim	A/R
Turbo PN: 452187-5006S			40mm	52mm	0.51	50mm	43mm	72	0.67

Garrett GT2554R

Horsepower: 170 - 270
 Displacement: 1.4L - 2.2L

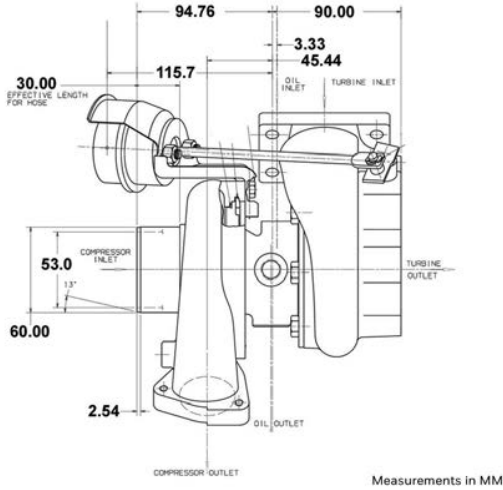

COMPRESSOR MAP

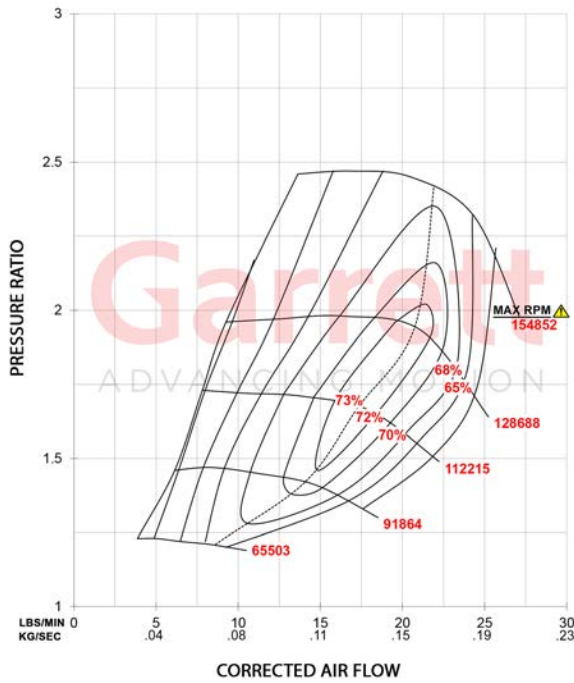

FEATURES:

- ◆ ORIGINAL GT SERIES AERODYNAMICS
- ◆ INTERNALLY WASTEGATED TURBINE HOUSING
- ◆ SOLD AS A COMPLETE TURBO (INCLUDES TURBINE KIT & ACTUATOR)
- ◆ SMALLEST BALL BEARING CONFIGURATION AVAILABLE
- ◆ WATER COOLED CHRA

EXHAUST FLOW CHART

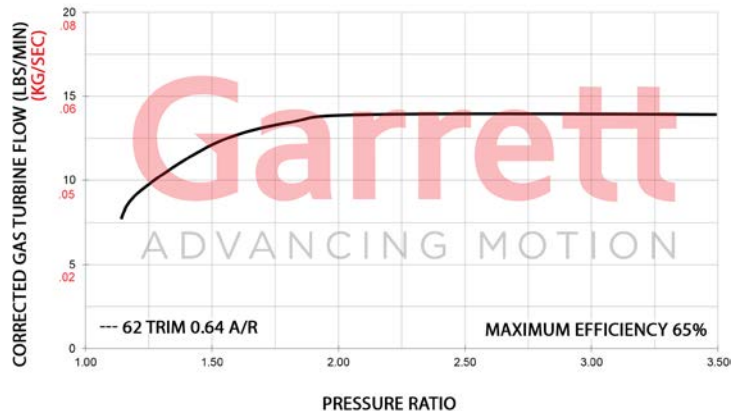

GT2554R		Compressor			Turbine			
HP: 170-270	Disp: 1.4L-2.2L	Inducer	Exducer	A/R	Inducer	Exducer	Trim	A/R
Turbo PN: 836023-5001S		42mm	54mm	0.80	53mm	42mm	62	0.64

Garrett GT2560R

Horsepower: 200 - 330

Displacement: 1.6L - 2.5L

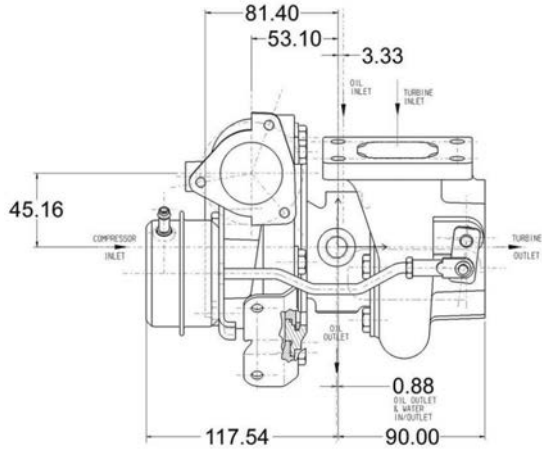

Measurements in MM



COMPRESSOR MAP

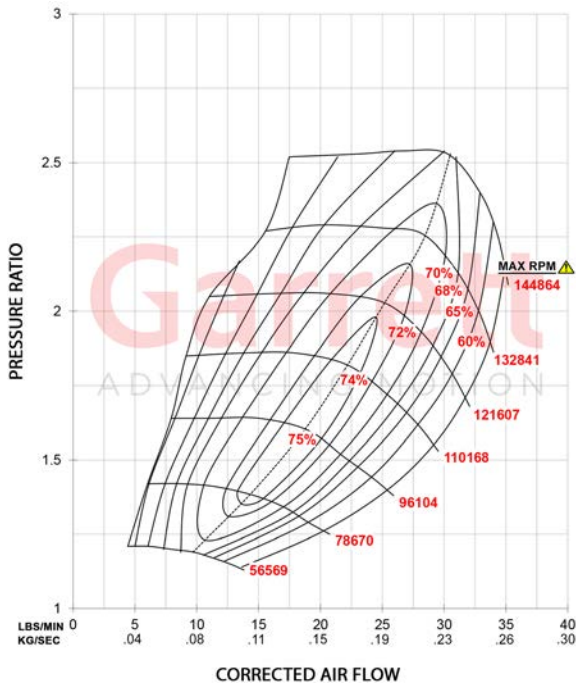

FEATURES:

- ◆ ORIGINAL GT SERIES AERODYNAMICS
- ◆ INTERNALLY WASTEGATED TURBINE HOUSING
- ◆ SOLD AS A COMPLETE TURBO (INCLUDES TURBINE KIT & ACTUATOR)
- ◆ BALL BEARING CONFIGURATION WITH WATER COOLED CHRA

EXHAUST FLOW CHART

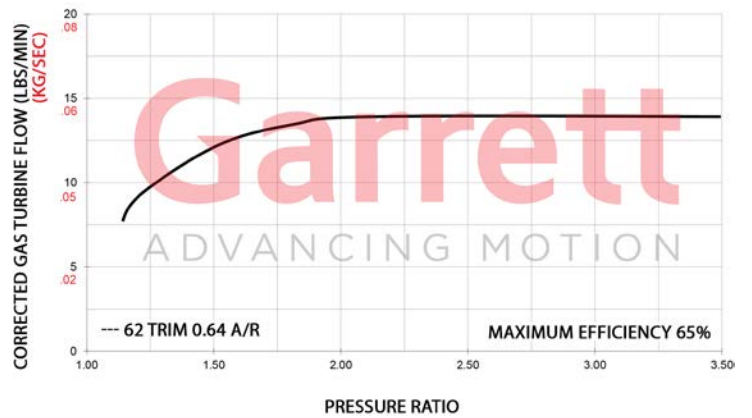

GT2560R		Compressor			Turbine			
HP: 200-330	Disp: 1.6L-2.5L	Inducer	Exducer	A/R	Inducer	Exducer	Trim	A/R
Turbo PN: 836023-5004S		46mm	60mm	0.80	53mm	42mm	62	0.64

Garrett GT2860R

Horsepower: 250 - 360
Displacement: 1.8L - 3.0L

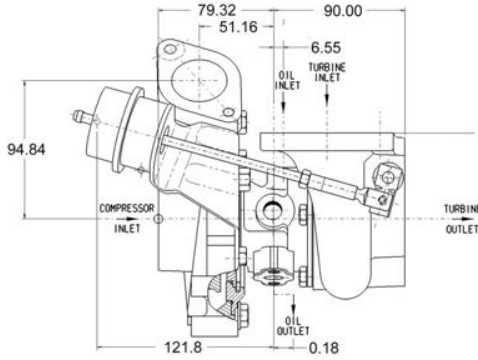

Measurements in MM

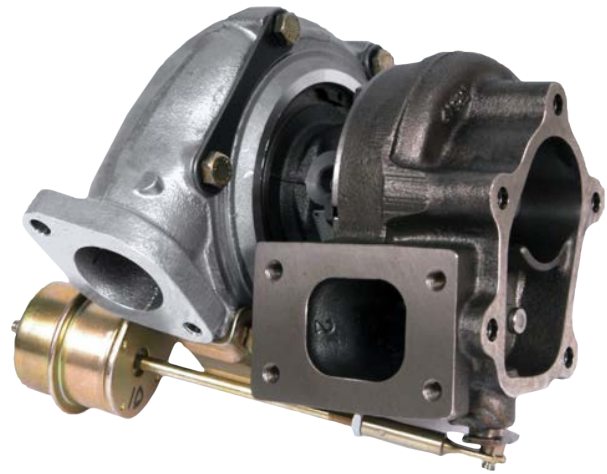

COMPRESSOR MAP

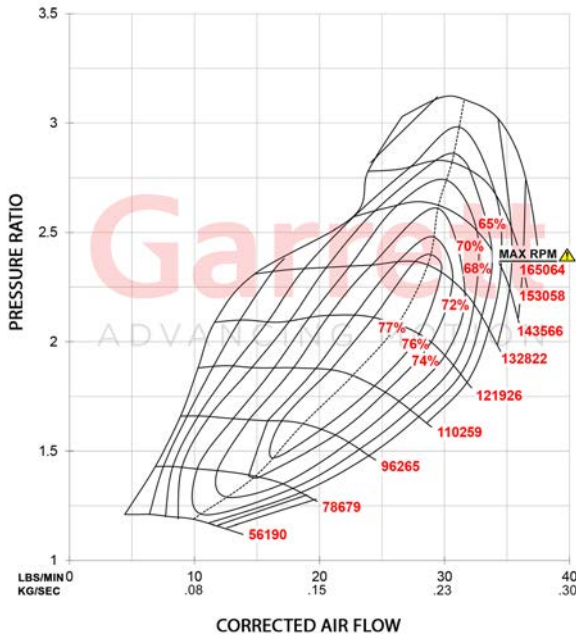

FEATURES:

- ◆ ORIGINAL GT SERIES AERODYNAMICS
- ◆ INTERNALLY WASTEGATED TURBINE HOUSING
- ◆ SOLD AS A COMPLETE TURBO (INCLUDES TURBINE KIT & ACTUATOR)
- ◆ BALL BEARING CONFIGURATION WITH WATER COOLED CHRA
- ◆ V-BAND TURBINE HOUSING OPTIONS
- ◆ BOLT-ON UPGRADE FOR NISSAN RB26DETT

EXHAUST FLOW CHART

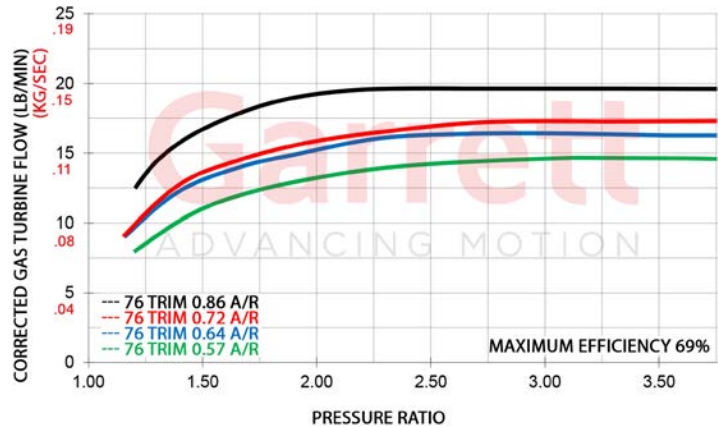

GT2860R HP: 250-360 Disp: 1.8L-3.0L Turbo PN: 836026-5005S	Compressor			Turbine			
	Inducer	Exducer	A/R	Inducer	Exducer	Trim	A/R
Kits not directly interchangeable.	47mm	60mm	0.60	54mm	47mm	76	0.64
Modifications required to the exhaust system to fit.	PN		A/R	Inlet	Outlet	Wastegate	Divided
	827690-0005		0.64	T25	5-Bolt	Internal	N
	827690-0004		0.86	T25	5-Bolt	Internal	N
	827690-0001		0.57	V-Band	V-Band	External	N
	827690-0002		0.72	V-Band	V-Band	External	N

Garrett GT2860RS

Horsepower: 250 - 360
 Displacement: 1.8L - 3.0L

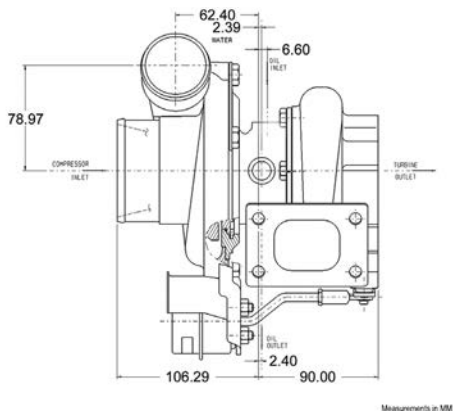

COMPRESSOR MAP

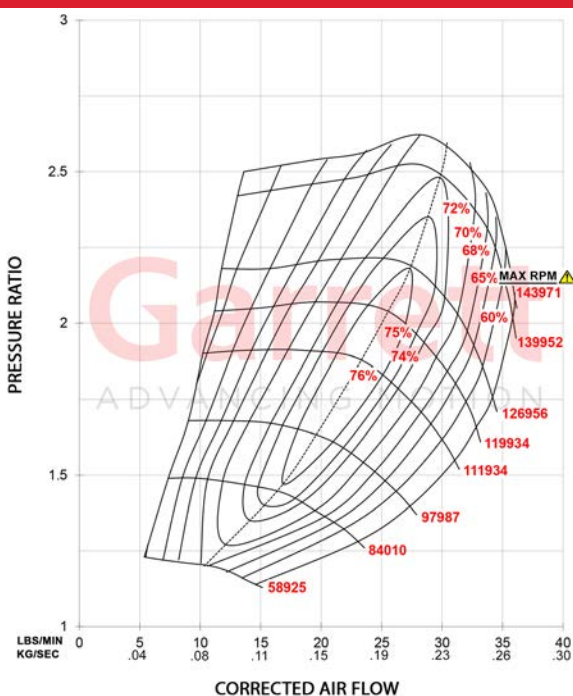

FEATURES:

- ◆ ORIGINAL GT SERIES AERODYNAMICS
- ◆ INTERNALLY WASTEGATED TURBINE HOUSING
- ◆ SOLD AS A COMPLETE TURBO (INCLUDES TURBINE KIT & ACTUATOR)
- ◆ BALL BEARING CONFIGURATION WITH WATER COOLED CHRA
- ◆ V-BAND TURBINE HOUSING OPTIONS

EXHAUST FLOW CHART

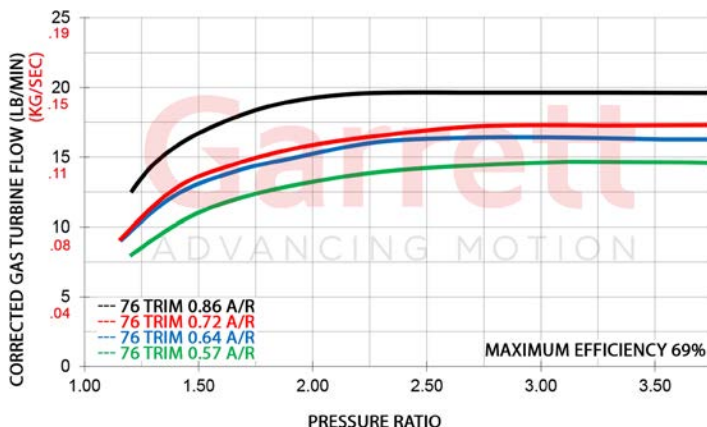

GT2860RS HP: 250-360 Disp: 1.8L-3.0L	Compressor			Turbine			
	Inducer	Exducer	A/R	Inducer	Exducer	Trim	A/R
Turbo PN: 836026-5013S	47mm	60mm	0.60	54mm	47mm	76	0.86
Turbo PN: 836026-5014S	47mm	60mm	0.60	54mm	47mm	76	0.64
Turbine Kits: GT28	PN		A/R	Inlet	Outlet	Wastegate	Divided
Kits not directly interchangeable.	827690-0005		0.64	T25	5-Bolt	Internal	N
Modifications required to the exhaust system to fit.	827690-0004		0.86	T25	5-Bolt	Internal	N
	827690-0001		0.57	V-Band	V-Band	External	N
	827690-0002		0.72	V-Band	V-Band	External	N

Garrett GT2871R

Horsepower: 280 - 475
Displacement: 1.8L - 3.0L

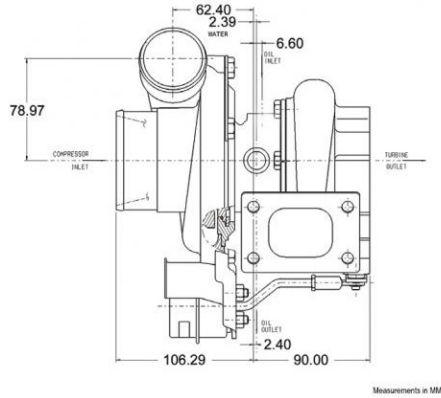

COMPRESSOR MAP

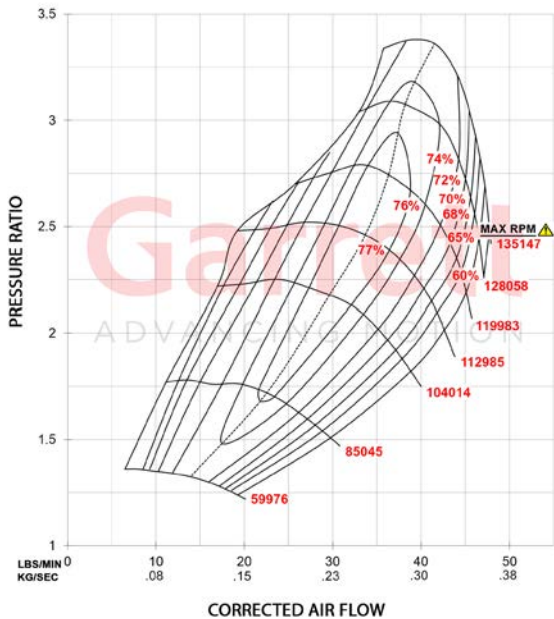

FEATURES:

- ◆ ORIGINAL GT SERIES AERODYNAMICS
- ◆ INTERNALLY WASTEGATED TURBINE HOUSING OPTIONS
- ◆ NON WASTEGATED TURBINE HOUSINGS AVAILABLE
- ◆ SOLD AS A COMPLETE TURBO (INCLUDES TURBINE KIT & ACTUATOR)
- ◆ BALL BEARING CONFIGURATION WITH WATER COOLED CHRA
- ◆ V-BAND TURBINE HOUSING OPTIONS

EXHAUST FLOW CHART

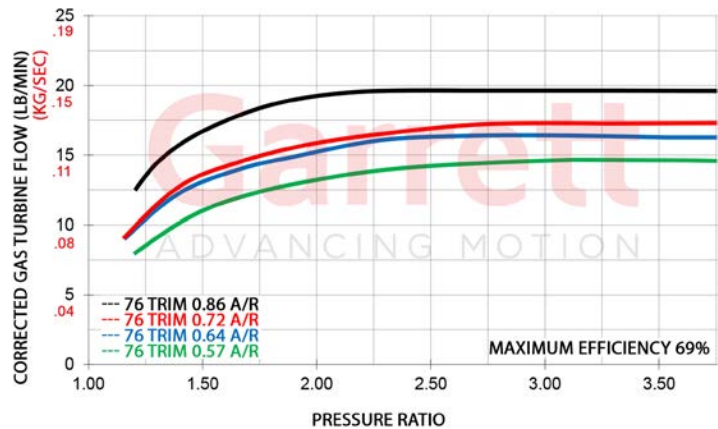

GT2871R HP: 280-475 Disp: 1.8L-3.0L	Compressor			Turbine			
	Inducer	Exducer	A/R	Inducer	Exducer	Trim	A/R
Turbo PN: 836026-5020S	53mm	71mm	0.60	54mm	47mm	76	0.86
Turbo PN: 836026-5021S	53mm	71mm	0.60	54mm	47mm	76	0.64
Turbine Kits: GT28	PN		A/R	Inlet	Outlet	Wastegate	Divided
Kits not directly interchangeable.	827690-0005		0.64	T25	5-Bolt	Internal	N
Modifications required to the	827690-0004		0.86	T25	5-Bolt	Internal	N
exhaust system to fit.	827690-0001		0.57	V-Band	V-Band	External	N
	827690-0002		0.72	V-Band	V-Band	External	N

Garrett GT3071R

Horsepower: 280 - 480
Displacement: 2.5L - 3.5L

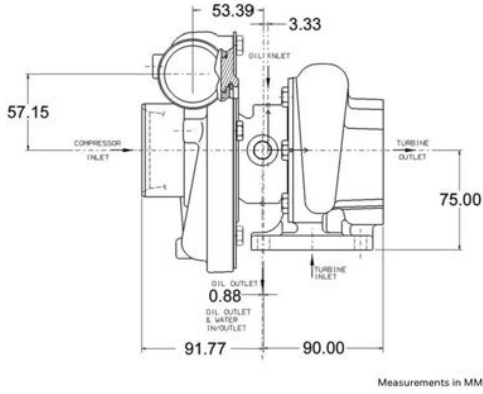

COMPRESSOR MAP

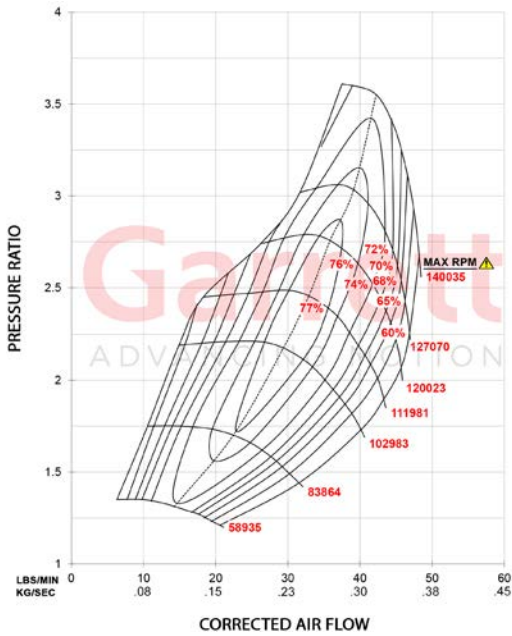

FEATURES:

- ◆ ORIGINAL GT SERIES AERODYNAMICS
- ◆ NON WASTEGATED TURBINE HOUSINGS AVAILABLE
- ◆ BALL BEARING CONFIGURATION WITH WATER COOLED CHRA
- ◆ V-BAND AND T3 TURBINE HOUSING INLET OPTIONS

EXHAUST FLOW CHART

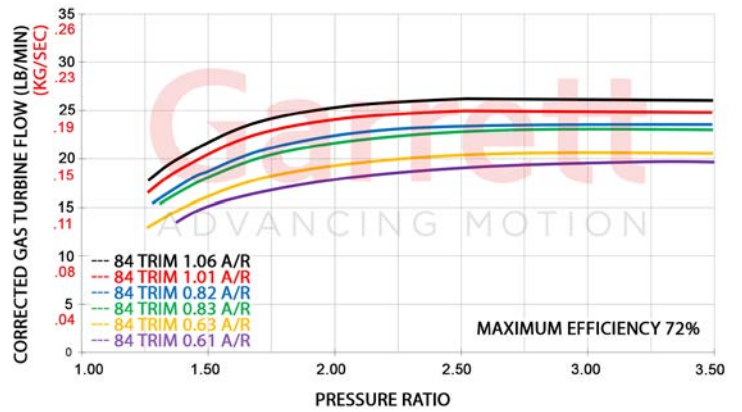

GT3071R		Compressor			Turbine		
HP: 280-480	Disp: 2.5L-3.5L	Inducer	Exducer	A/R	Inducer	Exducer	Trim
Supercore PN							
836028-5001S	69.85mm hose / square heat shroud	53mm	71mm	0.50	60mm	55mm	84
836028-5002S	102.00mm hose / square heat shroud	53mm	71mm	0.50	60mm	55mm	84
836028-5005S	102.00mm hose / stepped heat shroud	53mm	71mm	0.50	60mm	55mm	84
Turbine Kits: GT30		PN	A/R	Inlet	Outlet	Wastegate	Divided
Free Float		740902-0009	0.63	T3	V-Band	External	N
		740902-0008	0.82	T3	V-Band	External	N
		740902-0007	1.06	T3	V-Band	External	N
		740902-0036	0.61	V-Band	V-Band	External	N
		740902-0035	0.83	V-Band	V-Band	External	N
		740902-0034	1.01	V-Band	V-Band	External	N
		PN	A/R	Inlet	Outlet	Wastegate	Divided
771300 turbine assembly does not include bolts, clamps, or actuator		771300-0006	0.63	T3	5 bolt	Internal	N
		771300-0005	0.82	T3	5 bolt	Internal	N
		771300-0004	1.06	T3	5 bolt	Internal	N

Garrett GT3076R

Horsepower: 310 - 525
Displacement: 2.0L - 3.5L

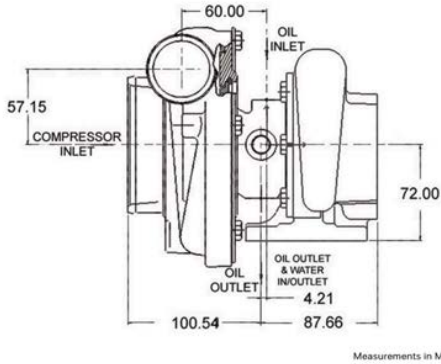

COMPRESSOR MAP

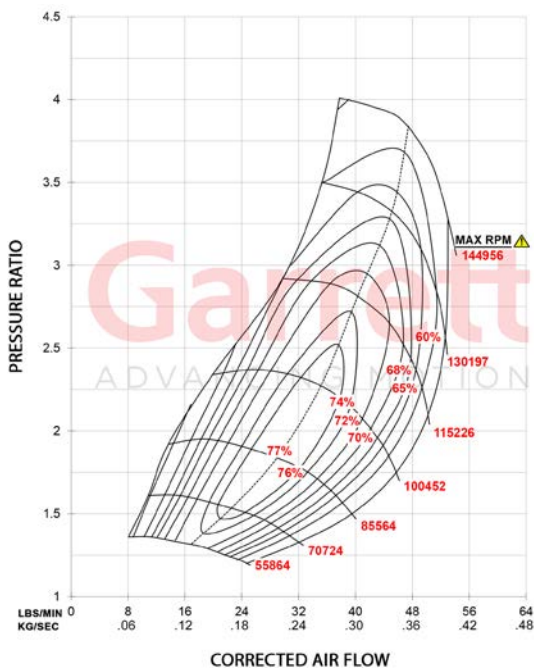

FEATURES:

- ◆ ORIGINAL GT SERIES AERODYNAMICS
- ◆ INTERNALLY WASTEGATED TURBINE HOUSING
- ◆ NON WASTEGATED TURBINE HOUSINGS AVAILABLE
- ◆ BALL BEARING CONFIGURATION WITH WATER COOLED CHRA
- ◆ V-BAND TURBINE HOUSING OPTIONS

EXHAUST FLOW CHART

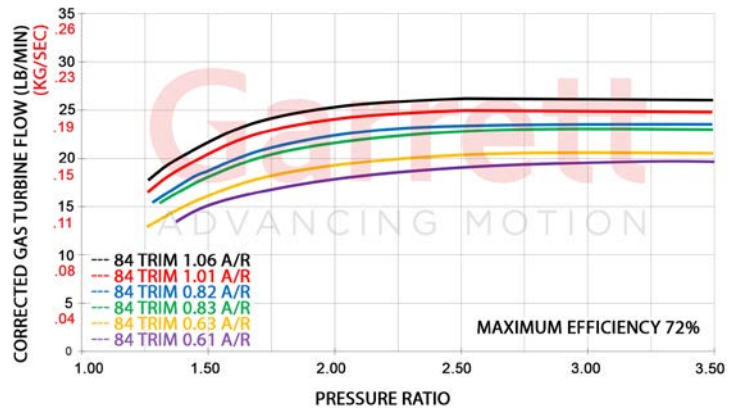

GT3076R		Compressor				Turbine		
		Inducer	Exducer	Trim	A/R	Inducer	Exducer	Trim
HP: 310-525	Disp: 2.0L-3.5L	57mm	76mm	56	0.60	60mm	55mm	84
Supercore		PN 836028-5003S						
Turbine Kits: GT30		PN	A/R	Inlet	Outlet	Wastegate	Divided	
Free Float		740902-0009	0.63	T3	V-Band	External	N	
		740902-0008	0.82	T3	V-Band	External	N	
		740902-0007	1.06	T3	V-Band	External	N	
		740902-0036	0.61	V-Band	V-Band	External	N	
		740902-0035	0.83	V-Band	V-Band	External	N	
		740902-0034	1.01	V-Band	V-Band	External	N	
		PN	A/R	Inlet	Outlet	Wastegate	Divided	
771300 turbine assembly does not include bolts, clamps, or actuator		771300-0006	0.63	T3	5 bolt	Internal	N	
		771300-0005	0.82	T3	5 bolt	Internal	N	
		771300-0004	1.06	T3	5 bolt	Internal	N	

Garrett GT3582R

Horsepower: 400 - 675
 Displacement: 2.0L - 4.5L

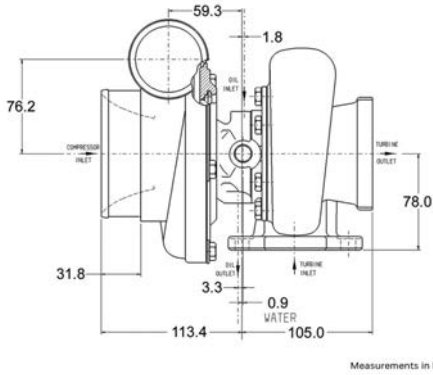

COMPRESSOR MAP

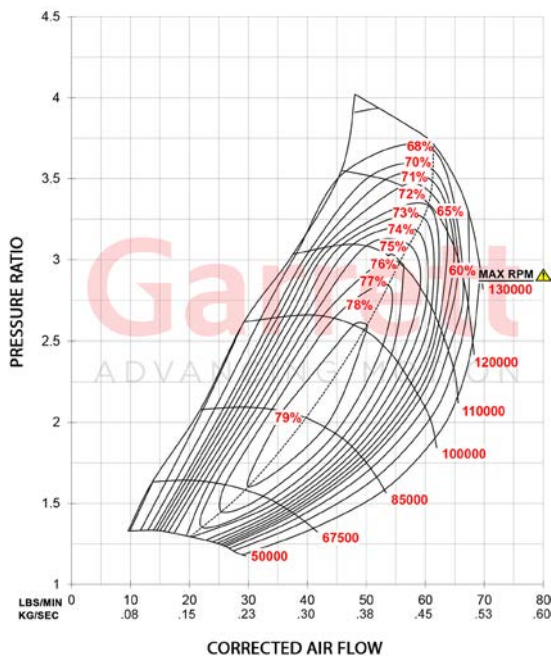

FEATURES:

- ◆ ORIGINAL GT SERIES AERODYNAMICS
- ◆ INTERNALLY WASTEGATED TURBINE HOUSING
- ◆ NON WASTEGATED TURBINE HOUSINGS AVAILABLE
- ◆ BALL BEARING CONFIGURATION WITH WATER COOLED CHRA
- ◆ V-BAND TURBINE HOUSING OPTIONS

EXHAUST FLOW CHART

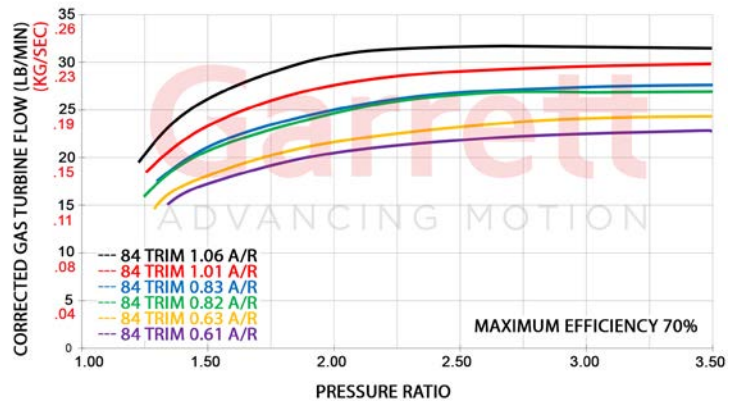

GT3582R	Compressor				Turbine				
	HP: 400-675	Disp: 2.0L-4.5L	Inducer 61mm	Exducer 82mm	Trim 56	A/R 0.70	Inducer 68mm	Exducer 62mm	Trim 84
Supercore	PN 836033-5002S								
Turbine Kits: GT35	PN A/R Inlet Outlet Wastegate Divided								
Free Float	740902-0012 0.63 T3 V-Band External N								
	740902-0011 0.82 T3 V-Band External N								
	740902-0010 1.06 T3 V-Band External N								
	740902-0018 0.63 T4 V-Band External N								
	740902-0017 0.82 T4 V-Band External N								
	740902-0016 1.06 T4 V-Band External N								
	740902-0033 0.61 V-Band V-Band External N								
	740902-0032 0.83 V-Band V-Band External N								
	740902-0031 1.01 V-Band V-Band External N								
	PN A/R Inlet Outlet Wastegate Divided								
771300 turbine assembly does not include bolts, clamps, or actuator	771300-0003 0.63 T3 5 Bolt Internal N								
	771300-0002 0.82 T3 5 Bolt Internal N								

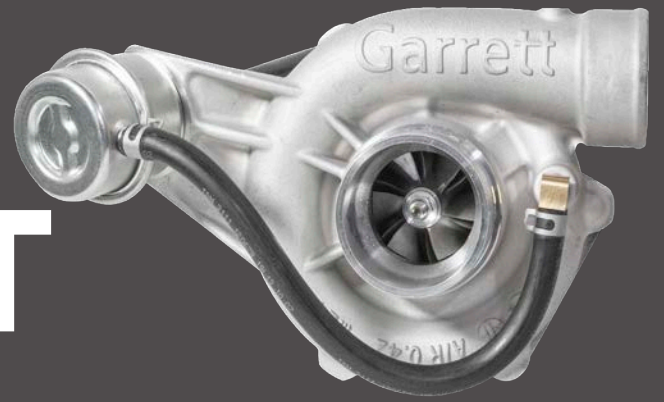

GARRETT CLASSIC

Garrett Classic Turbochargers seamlessly blend modern engineering with direct-fit installation, designed specifically for iconic European cars that ignited the auto industry's turbo revolution. Experience unparalleled performance and reliability, ensuring your vehicle maintains its legendary status while embracing cutting-edge technology.



Garrett Classic Turbo

Lancia Delta HF Integrale

Part Number: 917375-5004W



Garrett | Classic Turbo incorporates modern engineering with direct-fit installation for the iconic Lancia Delta HF Integrale 8V, 16V | Lancia Dedra | Alfa 155 2.0 Q4 | Fiat Coupe 16V. The modern journal bearing rotating group utilizes a 360-degree thrust bearing for improved reliability. Garrett integrated the actuator bracket into the compressor housing to strengthen the turbocharger. This turbocharger includes a gasket kit for a direct-fit installation.

FEATURES



- 360-degree thrust bearing to improve reliability and durability of the rotor system during extreme operating conditions
- Wastegate actuator bracket is cast into the compressor housing to improve stiffness against engine vibration
- Robust turbine housing, engineered using of thermal simulation to avoid cracks and other failures
- Includes gasket kit 917890-0001 (Turbine inlet, oil inlet, oil outlet)
- Direct-fit installation

Application List

Model	Year	Garrett DSR PN	Garrett PN	OE PN
Lancia Delta HF Integrale (8V, catalytic converter) Lancia Delta HF Integrale 16V	1989-1991	917375-5004W	465103-5002S	76317230
			465103-5004S	77202760
465103-5006S	76863370			
465103-5009S	77294710			
Lancia Dedra 2.0 Turbo Integrale	1991-1994		465103-5009S	77294710
Alfa 155 2.0 Q4 16V Turbo	1992-1994		465103-5004S	77202760
Fiat Coupé 2.0 16V Turbo	1993-1996	465103-5004S	77202760	

Garrett Classic Turbo

Renault 5 Turbo 1 & 2

Part Number: 920072-5001W



Introducing the Garrett Classic Turbo - the perfect blend of modern engineering and iconic design for your Renault 5 Turbo. Our state-of-the-art engineering technology ensures the ultimate driving experience by combining performance and reliability with direct-fit installation. It's journal bearing rotating group incorporates a 360-degree thrust bearing for enhanced reliability. We've integrated the actuator bracket into the compressor housing to ensure a stronger, more durable turbocharger that will keep your Renault 5 Turbo running smoothly for years to come.

Don't settle for anything less than world-class engineering and reliability for your automotive investment. By choosing Garrett Classic, the only original turbo, for the ultimate upgrade on your Renault 5 Turbo, you will increase the value of your car and you elevate your driving experience.

Model	Year	Garrett DSR PN	Garrett PN
Renault 5 Turbo 1	1980-1982	920072-5001W	465646-5003S
Renault 5 Turbo 2	1983-1985		465646-5004S



FEATURES

- 360-degree thrust bearing to improve reliability and durability of the rotor system during extreme operating conditions
- Wastegate actuator bracket is cast into the compressor housing to improve stiffness against engine vibration
- Robust turbine housing, engineered using of thermal simulation to avoid cracks and other failures
- Includes gasket kit 917890-0002 (oil inlet, oil outlet)
- Direct-fit installation

Garrett Classic Turbo

Lancia Delta HF Integrale 16V and 16V Evo1

Part Number: 917375-5005W



Garrett | Classic Turbo incorporates modern engineering with direct-fit installation for the iconic Lancia Delta 2.0 16V HF Integrale and EVO 1. The modern journal bearing rotating group utilizes a 360-degree thrust bearing for improved reliability. This turbocharger includes a gasket kit for a direct-fit installation.

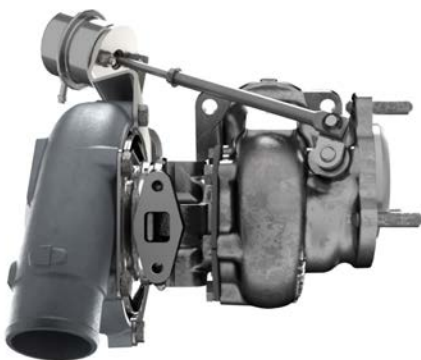

FEATURES

- 360-degree thrust bearing to improve reliability and durability of the rotor system during extreme operating conditions
- Separate Wastegate actuator bracket mounted to the compressor housing
- Robust turbine housing, engineered using of thermal simulation to avoid cracks and other failures
- Includes gasket kit 917890-0001 (Turbine inlet, oil inlet, oil outlet)
- Direct-fit installation

Application List

Model	Year	Garrett DSR PN	Garrett PN	OE PN
Lancia Delta HF Integrale 16V Evo 1	1991-1992	917375-5005W	465553-5001S	7662974
Lancia Delta HF Integrale 16V	1989-1991			46234219
				7662974

GARRETT VENT | WASTEGATES



Garrett Vent | External Wastegates regulate turbocharger shaft speed by venting exhaust gas around the turbine stage of the turbocharger. CFD optimized design maximizes flow and delivers optimum boost control. Advanced thermal optimization increases durability of the diaphragm. The cap design makes spring changes and serviceability of the entire GVW lineup easier and more reliable to perform.



Garrett Vent | External wastegates are created by the engineers that designed G-Series and GTX Gen II turbochargers. Available in three sizes: 40mm | 45mm | 50mm and four color combinations: Red | Blue | Black | Silver. The valve housing is cast from high temp stainless steel and rated for exhaust temperatures up to 1050° C. CFD optimized for maximum flow and thermal efficiency. Our Nomex reinforced elastomer diaphragm provides exceptional durability and fatigue resistance.

GVW wastegates are set to 1 Bar | 14.5 PSI of base pressure and can be configured from 0.2 Bar | 2.9 PSI - 1.7 Bar | 24.7 PSI (considering 1:1 back pressure). The actuator design allows for multiple air/liquid fitting orientations. All fasteners, springs, fittings, V-bands, clamps, and flanges included. For pricing and availability please contact an authorized distributor.

Model	Base Pressure	Red	Blue	Black	Silver
GVW-40	1 Bar 14.5 PSI	908827-0001	908827-0002	908827-0003	908827-0004
GVW-45	1 Bar 14.5 PSI	908828-0001	908828-0002	908828-0003	908828-0004
GVW-50	1 Bar 14.5 PSI	908829-0001	908829-0002	908829-0003	908829-0004
GVW-60	1 Bar 14.5 PSI	908830-0001	908830-0002	908830-0003	908830-0004

Features:

- CFD tested for maximum flow and thermal efficiency
- Optimized actuation stability and temperature resistance for superior durability
- Replaceable valve and bushing components to increase service life
- Robust design for easy diaphragm replacement
- Liquid-cooled actuator ports for use on severe applications (up to 52% reduction in body temp)
- Anodized aluminum actuator cover



Mechanical Data	GVW-40	GVW-45	GVW-50	GVW-60
Valve Diameter	40mm	45mm	50mm	60mm
Valve Mass	1.27kg 45oz	1.47kg 52oz	1.56kg 55oz	1.74kg 61oz
Max Spring Base Pressure	1.7 bar 25 psi (1:1 backpressure ratio)			
Minimum Spring Base Pressure	0.2 bar 3 psi (1:1 backpressure ratio)			
Port Fitting: Air	M10x1.0 to hose barb (Hose ID 6mm .25in)			
Port Fitting: Liquid	M8x1.0 to AN-3			

Material Data	GVW-40 GVW-45 GVW-50 GVW-60
Valve Housing	High temp stainless steel rated up to 1050°C
Diaphragm	High temp Nomex reinforced elastomer
Actuator Cover	Fully-machined anodized 6061 aluminum
Valve Guide/Bushing	Nitronic 60
Valve	High temp stainless steel with plated stem
V-Band	CNC machined 304 stainless steel
Flanges	Fully-machined 304 stainless steel
Springs	17/7 PH stainless steel

Thermal Data	GVW-40 GVW-45 GVW-50 GVW-60
Max Thermal Stress (Non-Cooled)	270°C actuator body temp during thermal cycle test
Max Thermal Stress (Liquid-Cooled)	130°C actuator body temp during thermal cycle test
Max Exhaust Temp: Peak	Up to 1050°C



Flow Data

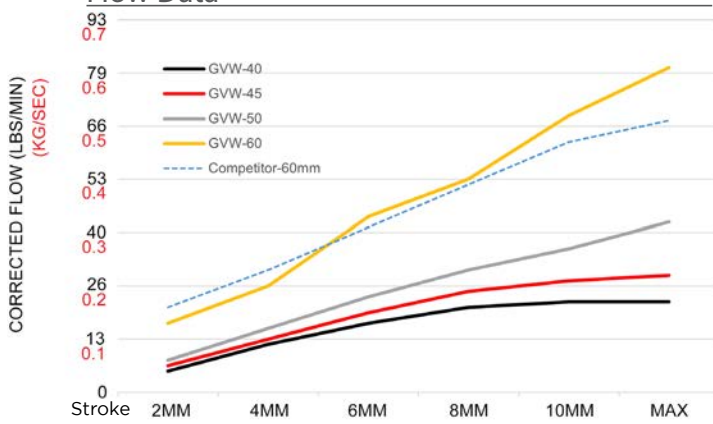

Actuation Durability Test Data

When researching and testing common shortfalls of wastegates, we observed how heat cycling and normal wear can rapidly change their actuation characteristics. Garrett engineers created GVW as a high flowing product with low degradation in performance over its lifespan.

Actuation data (opening and closing) in the chart was measured before and after extreme testing conditions. Results show the heat cycled GVW product maintains linear control of the wastegate as compared to the new product.

Precise actuation of the GVW provides accurate calibration settings and performance throughout the lifespan of the product. Accurate wastegates, allow for optimum performance of the turbocharger.

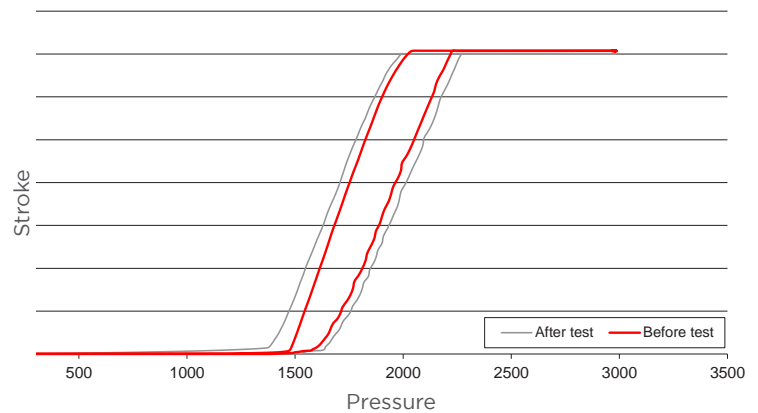

Spring Pressure Chart

	PSI	3	4	6	7	9	10	12	13	Base Pressure	16	17	19	20	22	23	25
GVW-40	Bar	0.2	0.3	0.4	0.5	0.6	0.7	0.8	0.9	1	1.1	1.2	1.3	1.4	1.5	1.6	1.7
Red		x					x	x			x						
Blue			x						x	x		x			x	x	x
Green				x				x	x				x			x	
White					x				x					x	x		x
Brown						x				x						x	
Purple											x	x	x	x		x	x
GVW-45	PSI	3	4	6	7	9	10	12	13	14.5	16	17	19	20	22	23	
GVW-50	Bar	0.2	0.3	0.4	0.5	0.6	0.7	0.8	0.9	1	1.1	1.2	1.3	1.4	1.5	1.6	
Blue		x				x	x		x	x	x				x	x	
Green			x									x	x		x		
White				x		x		x		x				x			x
Brown					x		x	x	x	x	x	x					
Purple													x	x	x	x	
Black											x	x	x	x	x	x	
GVW-60	PSI	3	4	6	7	9	10	12	13	14.5	16	17	19	20	22	23	
	Bar	0.2	0.3	0.4	0.5	0.6	0.7	0.8	0.9	1	1.1	1.2	1.3	1.4	1.5	1.6	
Blue							x	x					x			x	
Green		x							x					x			
White			x							x					x	x	
Yellow					x		x					x	x	x	x	x	
Purple				x							x						
Aqua Blue						x		x	x	x	x	x	x	x	x	x	

Spring pressures are calculated based on a 1:1 boost/backpressure ratio. Actual intake manifold (boost) pressure can vary

GARRETT VENT | EXTERNAL WASTEGATES

Ancillary Part Chart | Tightening Torque Specs



Description	Tightening Torque Nm ft-lb	GVW-40	GVW-45	GVW-50	GVW-60
Kit: Air Fitting (Banjo Fitting, Bolt, 2 Crush Washers)	15 11		910477-0001		
Kit: Diaphragm (Diaphragm Assy, Valve Stem Nut)	10 7	910476-0001	910476-0002		910476-0003
Kit: Valve/Bushing (Valve,Bushing,Seal Washer,O-Ring,Valve Stem Nut,Seat)	10 7	910478-0001	910478-0002	910478-0003	910478-0004
Kit: V-Band Inlet (V-Band, Bolt, Locknut)	15 11	910475-0001	910475-0003	910475-0004	910475-0005
Kit: V-Band Outlet (V-Band, Bolt, Locknut)	15 11	910475-0002	910475-0001	910475-0003	910475-0006
Bolt, Actuator Body	5 4		Bolt Not Available		
Bolt, Actuator Cap	2.5 2.0		894537-0001		
Bolt, V-band	N/A		894540-0006		
Bolt, Banjo Fitting	15 11		Included In Air Fitting Kit		
Bushing	30 22		Included In Valve/Bushing Kit		
Fitting, Water 8mm	10 7		895520-0001		
Fitting, Plug Air 10mm	15 11		895519-0001		
Flange, Inlet Weld	N/A	894649-0003	894649-0001	894649-0007	894649-0005
Flange, Outlet Weld	N/A	894649-0004	894649-0002	894649-0008	894649-0006
Locknut, V-band	15 11		905694-0001		
Nut, Valve	10 7		Included In Valve/Bushing Kit		
Seat, Valve	N/A	894648-0002	894648-0001	894648-0004	894648-0003
Spring, Red (See Spring Chart For Spring Pressure)	N/A	898344-0001			
Spring, Blue (See Spring Chart For Spring Pressure)	N/A		898344-0002		
Spring, Green (See Spring Chart For Spring Pressure)	N/A		898344-0003		
Spring, White (See Spring Chart For Spring Pressure)	N/A		898344-0004		
Spring, Brown (See Spring Chart For Spring Pressure)	N/A		898344-0005		
Spring, Purple (See Spring Chart For Spring Pressure)	N/A		898344-0006		
Spring, Black (See Spring Chart For Spring Pressure)	N/A		898344-0008		
Washer, Crush 8mm	N/A		895518-0002		
Washer, Crush 10mm	N/A		895518-0001		

GVW Replacement Part Kits

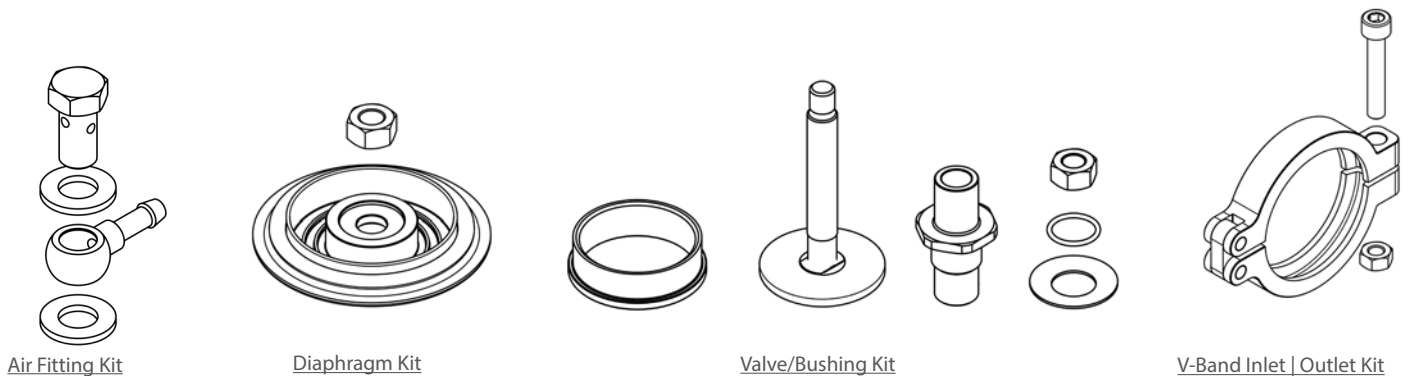

Air Fitting Kit

Diaphragm Kit

Valve/Bushing Kit

V-Band Inlet | Outlet Kit

GARRETT VENT | BLOW-OFF VALVES

Garrett Vent | Blow-Off Valves release excess boost pressure from the charge pipe when the throttle is closed, preventing damage to the turbocharger and other engine components, ensuring smooth operation and prolonging the turbo's lifespan.



GARRETT VENT | BLOW-OFF VALVES

High-Flowing Blow-Off Valves for Performance Engines

Garrett Vent | Blow-Off Valves are created by the engineers that designed G-Series turbochargers and GVW Wastegates. GVB-50 is a high-flowing BOV with a 50mm valve, available in four striking color combinations. Select between vent to atmosphere (VTA) and recirculating (RCV) housing options. Delivering a maximum flow up to 350 CFM | .21kg/s (RCV) as a result of advanced CFD design software used to simulate, visualize, and quantify airflow before manufacturing started (GVB-50R RCV). The proprietary designed, high-temperature Nomex reinforced elastomer diaphragm ensures unmatched durability and fatigue resistance. A plated stem and bushing lower friction and improve wear resistance.

GVB Blow-Off Valves are set to 10 PSI of base pressure and offer configurable rates from 0.2 Bar | 3 PSI - 0.9 Bar | 13 PSI. Unlike the other products on the market, Garrett includes five springs enabling fine tuning of the pressure setting to optimize BOV performance, and therefore overall turbo system performance. The single vacuum port streamlines functionality. Every kit contains- all fasteners, springs, fittings, V-bands, clamps, and flanges. For pricing and availability please contact an authorized distributor.

Spring Settings: _____



GVB-50	PSI	Base Pressure							
		3	4	6	7	9	10	12	13
	Bar	0.2	0.3	0.4	0.5	0.6	0.7	0.8	0.9
Red		x			x	x			x
Blue			x				x		
Green					x				x
White						x	x	x	
Brown				x				x	x

Model	Part Number	Base Pressure	Color	Description
GVB-50A	914956-0001	10PSI	Red	Vent to atmosphere
GVB-50A	914956-0002		Blue	Vent to atmosphere
GVB-50A	914956-0003		Black	Vent to atmosphere
GVB-50A	914956-0004		Silver	Vent to atmosphere
GVB-50R	914959-0001		Red	Recirculating housing
GVB-50R	914959-0002		Blue	Recirculating housing
GVB-50R	914959-0003		Black	Recirculating housing
GVB-50R	914959-0004		Silver	Recirculating housing
GVB-50R	913283-0001	Outlet Hose Adapter 1.00" (25.4mm)		
GVB-50R	913283-0002	Outlet Hose Adapter 1.14" (29.0mm)		
GVB-50R	913283-0003	Outlet Hose Adapter 1.34" (34.0mm)		
GVB-50R	913283-0004	Outlet Hose Adapter 1.50" (38.1mm)		

Features:

- CFD tested for maximum flow and thermal efficiency
- Replaceable components to increase service life
- Robust design for easy diaphragm replacement
- 6061 Anodized aluminum actuator cover and fully-machined billet housing
- Maximum flow 350 CFM | .21kg/s for GVB-50R
- Four outlet adapters for the recirculating valve. Adapters sold separately
- Base pressure 0.7 Bar | 10 PSI (blue and white spring installed)
- Configurable springs settings include: 3 | 4 | 6 | 7 | 9 | 10 | 12 | 13 PSI
- Wrought Aluminum Alloy Weld Flange
- 17/7 PH Stainless Steel Springs
- Plated stem and bushing for lowered friction and wear resistance
- High temp nomex reinforced diaphragm
- Stainless steel fittings and fasteners



Flange Diagrams

- BOV flange dimensions interchangeable with Tial Q and QR

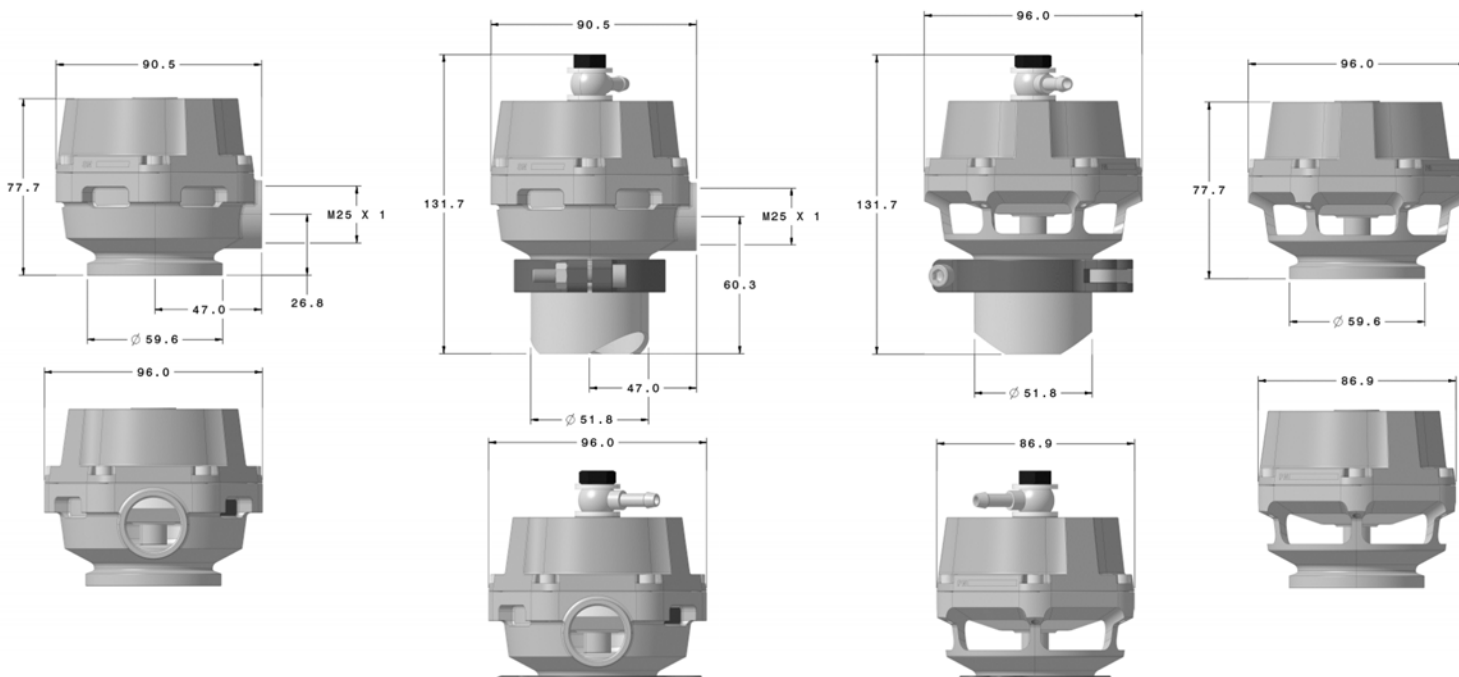



Garrett
ADVANCING MOTION

ACCESSORIES

PN	Kit Type	Description	Speed Sensor	Harness	Gauge	Bolt
781328-0001	Street	GTX Gen II GTX GT GTW	Y	Y	Y	
781328-0002	Pro	GTX Gen II GTX GT GTW	Y	Y		
781328-0003	Street	G Series GTX55 Gen II GTX50 Gen II GTX47 Gen II	Y	Y	Y	Y
781328-0004	Pro	G Series GTX55 Gen II GTX50 Gen II GTX47 Gen II	Y	Y		Y

Speed Sensors: Select Garrett turbochargers come standard with a fully machined speed sensor port. Just remove the bolt and screw in the appropriate kit for your application. GT and GTX Gen I turbos can be machined by a shop of your choice to retrofit the speed sensor port. G-Series turbochargers utilize a new and easy to install sensor that does not need to be calibrated. GT/GTX speed sensor kits not applicable with G-Series turbochargers.

Maximum Performance

Comparing boost levels and shaft speed on a compressor map, you can determine the ideal operating conditions to ensure peak power over a wider operating range. All Garrett Turbocharger Speed Sensor Kits are compatible with data loggers to enhance engine tuning capability. In addition, the Garrett-branded gauge's maximum speed recall function will retain the highest wheel speed for five minutes for easy mapping. The data gained from the Garrett Turbocharger Speed Sensor Kit can be used to closely estimate the engine's flow behavior without a flow bench. Flow information is invaluable for determining if the turbocharger is reaching its maximum performance, for validating the turbo match, and for ensuring that it is not over speeding, allowing you to avoid potentially damaging operating conditions. This kit could even be used in conjunction with an aftermarket ECU to limit compressor speed. The Garrett Turbocharger Speed Sensor Kit will help you be sure you've got the correct turbo for your needs!

Easy To Use

The Garrett Turbocharger Speed Sensor works with any turbocharger to accurately determine compressor wheel speed. The instructions include detailed drawings of the exact machining specifications for all Garrett GT and GTX Gen I catalog turbochargers as well as general guidelines for other compressor housing types. G-Series / GTX55 Gen II / and GTX50 Gen II turbochargers use a new sensor that eliminates the calibration process. The Garrett Turbocharger Speed Sensor Kit includes all necessary wiring for easy installation and simple data logging.



Boost Gauge: The Garrett Mechanical Boost Gauge is the perfect addition to your interior for the important job of accurately monitoring your boost levels. The gauge has a sleek design and features a black face, white back lit numbers and a brushed aluminum ring. The gauge monitors boost from 30 Hg of vacuum to 30 psi of boost and is available in PSI and BAR configurations.

Boost Gauge Components: gauge, mounting bracket, hose, fitting, mounting hardware.

Boost Gauge PSI Part Number: 773326-0001

Boost Gauge BAR Part Number: 773326-0002



Divided V-Band Inlet Adapter: The Garrett divided V-Band adapter is for enthusiasts that are fabricating divided exhaust manifolds. This adapter mates perfectly with GT/GTX 30 and 35 divided V-Band turbine housings and has two 2" recessed orifices that feed into the flange.

Turbine Inlet Divided V-Band Adapter: Compatible with GT/GTX 30 & 35 divided turbine housings.

V-Band Adapter Part Number: 813444-0001



V-Band Turbine Outlet Adapter: The Garrett V-Band outlet adapter is for fabricating the turbo down pipe. This adapter mates perfectly with the G25 | G30 | G35 | GT30 | GT35 | GTX30 | GTX35 turbine housing outlet. It has a 3" recessed opening feeding the flange.

V-Band Adapter Part Number: 774175-0001



Adjustable Wastegate Bracket: The Garrett Adjustable Wastegate Bracket allows for a greater range of motion to set up the compressor outlet and wastegate can. The bracket also allows for redirection of the actuator to keep vacuum lines away from heat or sharp edges. The adjustable actuator bracket is available for use on GT25R, GT28R and GT30R turbochargers.

V-Band Adapter Part Number: 773151-0002



Actuator Kits: Garrett actuator kits are for use on internally wastegated turbine housings. These kits are designed to regulate shaft speed by venting exhaust gas out of the turbine housing.

PN	Model	Bar	Actuator Assembly
480009-0009	G GT GTX28	0.5	Actuator
480009-0006	G GT GTX28	1.0	*Rod end, jam nut, bracket, heat shield, retaining clip not included
480009-0010	G GT GTX28	1.5	



Kit PN	Model	Bar	Actuator Assembly Kit
700187-0001	T25		Actuator (fixed rod), bracket, heat shield.
759498-0001	GT GTX28	0.5	Actuator, rod end, jam nut, retaining clip. *Bracket and heat shield not included
759498-0007	GT GTX28	1.0	
759498-0005	GT GTX28	1.5	
759498-0004	GT GTX35R	0.8	
759498-0008	G25	0.5	G-Series V-band standard rotation, actuator, bracket and bolts, rod end, jam nut, retaining clip. *Heat shield not included
759498-0009	G25	1.0	
759498-0010	G25	1.5	
759498-0011	G25	0.5	G-Series V-band reverse rotation, actuator, bracket and bolts, rod end, jam nut, retaining clip. *Heat shield not included
759498-0012	G25	1.0	
759498-0013	G25	1.5	
759498-0014	G25	0.5	G-Series T4 standard rotation, actuator, bracket and bolts, rod end, jam nut, retaining clip. *Heat shield not included
759498-0015	G25	1.0	
759498-0016	G25	1.5	

•759498-0004 for use with turbine housing wastegate family 771300

G-SMART

BLUETOOTH MODULE

Track your turbo's performance in real-time with the Garrett G-Smart Module. Transmit turbo speed and boost via Bluetooth with the free G-Smart application. This important data will allow users to see if they are operating the turbocharger within its recommended RPM limits to optimize durability and performance. The Garrett G-Smart Module is your turbocharger's ultimate companion, guiding you towards unparalleled performance.



PRISHOW
[FEATURED PRODUCTS]
SHOWCASE TOP 3
BEST ENGINE PRODUCT



Easy to Install and Setup

Say goodbye to tangled wires and tedious setups. Bluetooth functionality means no wires through the firewall for a quick, and easy installation. The plug-and-play harness accepts Garrett flange and threaded style speed sensors. Kits are available without a speed sensor for users who already have a speed sensor and with for those who don't have one. A 12V switched power and sufficient ground connection are all you need to get started. The Sensor Setup menu is loaded with existing Garrett Turbocharger part numbers, models, compressor wheel blade counts and max-rated turbo speed. Custom configurations can also be created for Garrett models without speed sensor ports or for non-Garrett manufactured turbochargers that utilize the same style speed sensors. For use with iOS and Android mobile devices. (Mobile device and mount not included.)

PN	Kit Description	Speed Sensor	Harness	Module
923586-0002	Module Harness Threaded Speed Sensor (GTX Gen II 28,30,35 and Custom Installation)	Threaded	Y	Y
923586-0003	Module Harness Flange Speed Sensor (G-Series GTX Gen II 47 50 55 PowerMax)	Flange	Y	Y
923586-0004	Module Harness	No	Y	Y



Flange Sensor Threaded Sensor

Analyze Turbo Speed and Boost Pressure

With the device paired and the car running, the mobile device screen will light up with live turbo speed and boost pressure (if connected) in a dynamic gauge and graphical format. The gauge display features a constant live data feed and has a marker that freezes on peak turbo speed.

The graph plot length can display up to 120 seconds of live data. The live data feed can be paused allowing users to review data points within the plot length with a touch of the screen. Users can connect the analog output to an external data logger/ECU for complete data logging.

WARNING

The use of any turbocharger product above maximum turbocharger speed is at the owner's risk and can result in damage and premature failure. To protect the turbocharger from overspeed when operating, a speed sensor can be installed into the compressor housing to monitor shaft speed.



FEATURES

- Bluetooth operation transmits data from the module to the G-Smart application
- Modern display with live turbo speed and boost pressure (if connected) readings
- Gauge sweep will transition color (G,Y,R) signaling the approach to max-rated turbo speed
- Marker on gauge sweep indicates peak turbo speed
- Display up to 120 seconds of turbo speed and boost data in easy-to-view graphical format
- Compatibility with both Android and iOS devices
- Easy installation and configuration with preset Garrett models and part numbers
- Create custom configurations for Garrett turbochargers without pre-machined speed sensor port or non-Garrett manufactured turbochargers
- Min/Max Turbo speed and boost pressure stored in app for future analysis



POWERMAX

PowerMax™ direct fit performance performance kits are engineered for increased engine performance while maintaining OEM direct fitment. With professional engine calibration and tuning, Garrett PowerMax will outperform the OEM product. These products are not approved for street use. Installation may affect the vehicle's safety, warranty, and operating license. For details, contact your vehicle's manufacturer or turbo kit distributor.



Important product information:

Garrett Performance Kits are professional aftermarket products only designed for certain racing vehicles driven on particular racing tracks and shall only be used on racing vehicles that will never be driven on public roads or highways. Garrett Performance Kits are not legal for use in vehicles on public roads or other roads to which public road law applies. Any vehicle modifications using Garrett Performance Kits are AT YOUR OWN RESPONSIBILITY and AT YOUR OWN RISK. Only use Garrett Performance Kits in compliance with all applicable laws, regulations and ordinances (including but not limited to emission, noise, operating license, performance, safety and type-approval aspects). A vehicle modification using Garrett Performance Kits may particularly affect or void a vehicle's warranty, operating license or type-approval. Moreover, only use Garrett Performance Kits in compliance with all applicable racing and racing track provisions. It is YOUR OWN RESPONSIBILITY AND RISK to ensure that your Garrett Performance Kit fits your vehicle and area of application. YOU MUST ENSURE LAWFUL AND SAFE OPERATIONS AT ANY TIME. You should particularly consult the owner's manual and service manual of your vehicle. You should also contact your vehicle's manufacturer to determine what effects modifications may have on important aspects such as safety, warranty, performance, etc. Only install and use Garrett Performance Kits if you have fully read and understood this important safety information and if you fully agree with the terms and conditions set forth therein.



2014 - 2018
VOLKSWAGEN | AUDI 2.0L
TSI MK7 STAGE 1 | STAGE 2



2020+
VOLKSWAGEN | AUDI | SKODA 2.0L
MK8 EA888 STAGE 1



2020+
VOLKSWAGEN GOLF R | AUDI 2.0L
TSI EA888 EVO4



2017 +
FORD ECOBOOST 3.5L
F-150 | RAPTOR | STAGE 2



2011 - 2021
FORD EVEREST | RANGER PX1 PX2 PX3
2011 - 2020
MAZDA BT-50



2007 - 2018
TOYOTA 4.5L
LAND CRUISER 1VD-FTV



2011 - 2017
FORD ECOBOOST 3.5L
F-150 | EXPEDITION | STAGE 1



2003 - 2011
VOLKSWAGEN | AUDI | 1.9L 2.0L
BEETLE | GOLF | JETTA | PASSAT | A3



2011 - 2016
CHEVROLET | GMC 6.6L
2500HD | 3500HD



1999.5 - 2007
FORD POWERSTROKE 7.3L
F-250 | F-350



1995.5 - 2007
FORD POWERSTROKE 6.0L
F-250 | F-350



2004.5 - 2010
CHEVROLET | GMC 6.6L
2500HD | 3500HD STAGE 1 STAGE 2



2013 - 2018
FORD ECOBOOST 2.0L
FOCUS ST | ESCAPE | FUSION | TAURUS



2014 - 2019
HOLDEN | CHEVROLET 2.8L
COLORADO XLDE DIESEL



2015+
FORD ECOBOOST 3.5L | 2.7L
F-150 | RAPTOR



2013 - 2018
FORD ECOBOOST 2.0L
FOCUS ST



2015+
SUBARU 2.0L
WRX



2011 - 2021
FORD EVEREST | RANGER PX1 PX2 PX3
2011 - 2020
MAZDA BT-50



2015 +
BMW 3.0L
F80 M3 | F82 / F83 M4



2016 +
HONDA 1.5L
CIVIC TSI



2015 +
FORD ECOBOOST 2.3L
MUSTANG



Use Your Smart Phone
Camera To Scan



POWERMAX™ DIRECT FIT PERFORMANCE TURBOCHARGERS

Applications: Stage 1 Turbo Upgrade for F-150 3.5L | Expedition | Navigator 3.5L (2011 - 2017)
Part Numbers 881027-5001S | 881028-5001S | 881027-5002S | 881027-5002S

This Garrett PowerMax™ turbocharger upgrade for the Ford 3.5L EcoBoost engine platform is engineered to increase engine performance capability while maintaining OEM installation specifications. This direct drop-in stage 1 upgrade provides 22% more flow than OEM and will support up to 300HP* from each turbo. Improvements in efficiency and flow can be attributed to the light weight forged fully-machined compressor wheel. Boost response of this PowerMax turbocharger compared to OEM has not been tested. This turbocharger kit comes fully assembled and calibrated and is outline interchangeable with the OE hardware to ensure a perfect fit every time. Contact your local authorized Garrett distributor for additional information and pricing.

**Please refer to the legal notice on page 114 before purchasing this product.*

Part Number	Year	Model	Make	Engine	OEM PN	Notes:
881027-5001S	2011-2012	F-150	Ford	3.5L EcoBoost	CL3Z-6K682-C	Left Turbocharger
881028-5001S	2011-2012	F-150	Ford	3.5L EcoBoost	CL3Z-6K682-D	Right Turbocharger
881027-5002S	2013-2017	F-150	Ford	3.5L EcoBoost	DL3Z-6K682-E	Left Turbocharger
881028-5002S	2013-2017	F-150	Ford	3.5L EcoBoost	DL3Z-6K682-F	Right Turbocharger
881027-5002S	2015-2017	Expedition	Ford	3.5L EcoBoost	DL3Z-6K682-E	Left Turbocharger
881028-5002S	2015-2017	Expedition	Ford	3.5L EcoBoost	DL3Z-6K682-F	Right Turbocharger
881027-5002S	2015-2017	Navigator	Lincoln	3.5L EcoBoost	DL3Z-6K682-E	Left Turbocharger
881028-5002S	2015-2017	Navigator	Lincoln	3.5L EcoBoost	DL3Z-6K682-F	Right Turbocharger

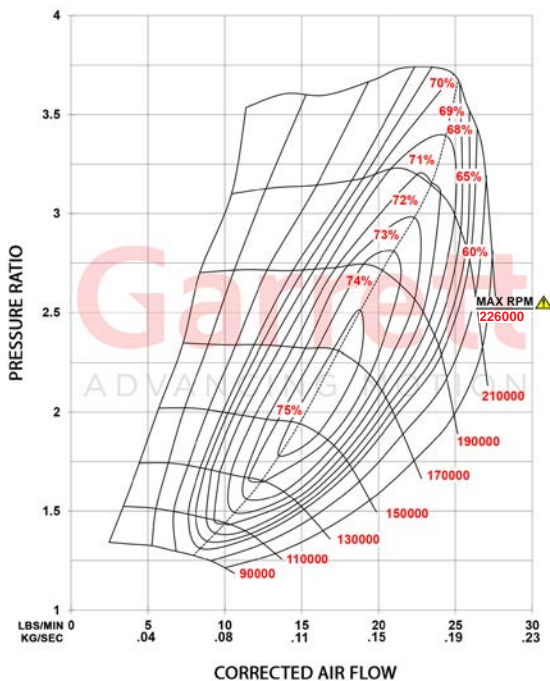

WARNING: Maximum allowable turbocharger speed is 226krpm. The use of this product above max turbocharger speed is at the owner's risk, and can result in damage and premature failure. To protect the turbocharger from overspeed when operating, a speed sensor port is machined into the compressor housing for the fitment of speed sensor part numbers 781328-0001 (includes sensor and gauge), and 781328-0002 (includes speed sensor). Speed sensors sold separately.

* Estimated Horsepower. Performance results of this product are highly dependent upon your vehicle's modifications and tuning/calibration. The horsepower numbers represented above are calculated based strictly on choke flow of the compressor map (total turbo capability), which represents the potential flywheel horsepower.



POWERMAX™ DIRECT FIT PERFORMANCE TURBOCHARGERS

Application: Stage 2 Turbo Upgrade For Ford Raptor | F-150 3.5L (2017 - 2021) Supports up to 700+HP**
Part Number 911984-5003S (Includes stock inlet adapter and o-ring. Does not include gaskets)

The Garrett PowerMax™ Stage 2 turbocharger upgrade for the 2017 - 2021 F-150 and F-150 Raptor platform is engineered to increase engine performance capability while maintaining OEM installation specifications. This direct drop-in Stage 2 upgrade provides 54% more flow than OEM and will support up to 700+ BHP*. Improvements in compressor efficiency and flow can be attributed to the 60mm fully-machined compressor wheel. Turbine flow is increased by 52% compared to OEM with a 50mm Inconel turbine wheel and larger 0.45 A/R turbine housing. This turbocharger kit comes fully assembled, calibrated, and is outline interchangeable with the OE hardware to ensure a perfect fit every time.

**Please refer to the legal notice on page 114 before purchasing this product.*

PowerMax Stage 2: 2017+ Ford F-150 F-150 Raptor				Compressor				Turbine		
Turbo PN	Bearing	Rotation	Actuation	Inducer	Exducer	Trim	A/R	Inducer	Exducer	Trim
911984-5003S	Journal	Standard	Electric	45mm	60mm	57	0.60	50mm	46mm	84
	Journal	Reverse	Electric	45mm	60mm	57	0.60	50mm	46mm	84

These turbochargers have received California Air Resources Board (CARB) certification. This certification (EO D-871) means our product has been tested in accordance with manufacturer/OEM specifications and meets the emissions standards set by the state of California and is approved for use in all 50 states when used as a drop-in replacement for factory equipment.

Features:

- Direct-fit Stage 2 upgrade (LH & RH Turbos)
- Compressor housing inlet (2.75") is larger than stock to allow for increased flow and optimized surge port
- Adapter for stock inlet tube included with turbo kit
- CARB Certified D-871
- 700+ BHP capability **
- Complete assembly with calibrated electric actuator
- Billet compressor wheel with 54% increased flow
- Inconel turbine wheel with 52% increased flow
- Modern compressor and turbine wheel aero
- Tuned ported shroud for optimal compressor surge and choke performance
- Speed sensor port: use PN 781328-0003 (street kit) or 781328-0004 (pro kit)
- Journal-bearing rotating group

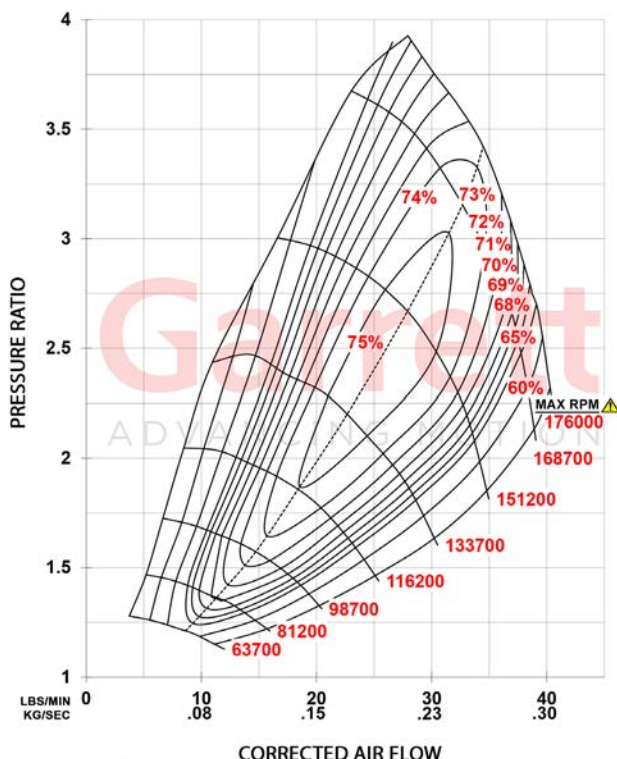

Stock inlet adapter (for use with the stock intake system) and the 2.75 inch adapter (for use with larger than stock intake systems) have different performance potentials.



WARNING: Maximum allowable turbocharger speed is 176krpm. The use of this product above max turbocharger speed is at the owner's risk, and can result in damage and premature failure. To protect the turbocharger from overspeed when operating, a speed sensor port is machined into the compressor housing for the fitment of speed sensor part numbers 781328-0003 (includes sensor and gauge), and 781328-0004 (includes speed sensor). Speed sensors sold separately.

** Estimated Horsepower. Performance results of this product are highly dependent upon your vehicle's modifications and tuning/calibration. The horsepower numbers represented above are calculated based strictly on choke flow of the compressor map (total turbo capability), which represents the potential flywheel horsepower.



POWERMAX™ DIRECT FIT PERFORMANCE TURBOCHARGERS

Application: Stage 1 & 2 TURBO UPGRADE FOR VW / Audi 2.0L TSI 2014 - 2021

Part Number: Stage 1 898199-5001W | Stage 2 898200-5001W

Garrett PowerMax™ turbocharger upgrades for the Volkswagen and Audi 2.0L TSI engine platform is engineered to increase engine performance while maintaining OEM installation specifications. Stage 1 (485 BHP*) and Stage 2 (600 BHP*) upgrades maximize efficiency and air flow compared to the OEM turbocharger. High temperature, Mar-M alloy turbine wheel and twin scroll stainless steel turbine housings are rated for up to 1050° C. These turbochargers are fully assembled with a calibrated electronic actuator and ancillary components for direct OEM fitment.

**Please refer to the legal notice on page 114 before purchasing this product.*

Part Number	Stage	Power	Model	Comp Ind	Comp Exd	Turb Ind	Turb Exd
898199-5001W	Stage 1	485HP 362kW	GT2260S	47mm	60mm	50mm	45mm
898200-5001W	Stage 2	600HP 447kW	G25-660	54mm	67mm	54mm	49mm

Stage 1 Features:

- Direct-fit stage 1 with 485HP | 362kW (flywheel) power capability (on-vehicle results)*
- Complete assembly with electronic actuator
- +17% compressor flow compared to IS38 turbo (stock Golf 4)
- GTX Gen II compressor aerodynamics
- Mar-M alloy turbine wheel and twin scroll stainless steel turbine housing rated up to 1050° C
- Latest generation of journal bearing rotating group with 360° reinforced thrust bearing

Stage 2 Features:

- Direct-fit stage 2 with 600HP | 447kW (flywheel) power capability (on-vehicle results)*
- Complete assembly with electronic actuator
- +59% compressor flow compared to IS38 turbo (stock Golf 4)
- G-Series compressor and turbine wheel aerodynamics
- Mar-M alloy turbine wheel and twin scroll stainless steel turbine housing rated up to 1050° C
- Latest generation of ball bearing rotating group

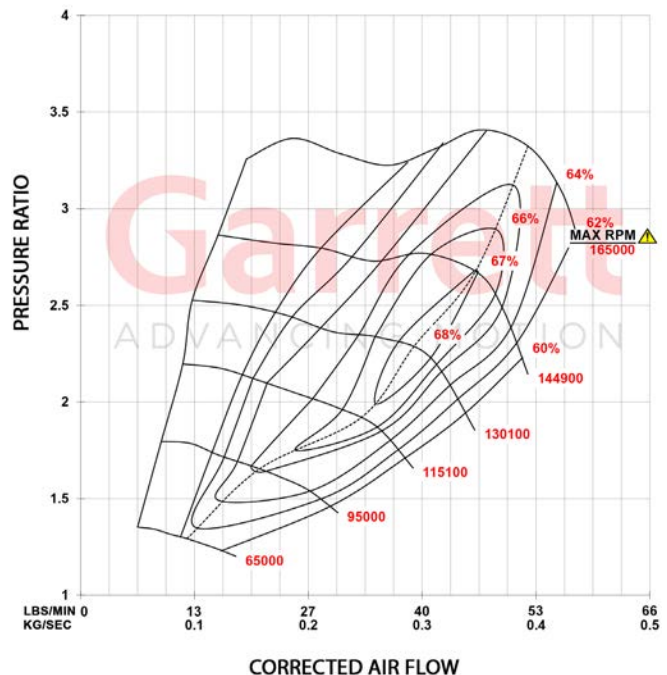
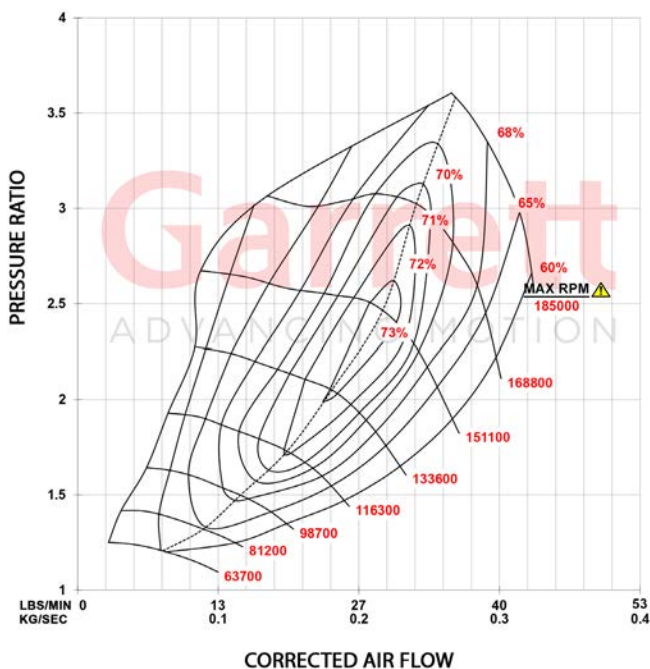

** Estimated Horsepower. Performance results of this product are highly dependent upon your vehicle's modifications and tuning/calibration. The horsepower numbers represented above are calculated based strictly on choke flow of the compressor map (total turbo capability), which represents the potential flywheel horsepower.

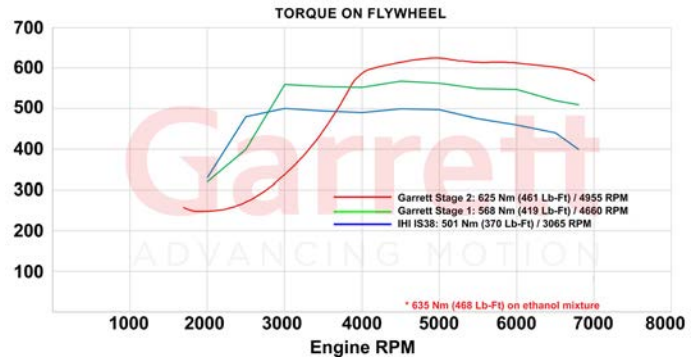
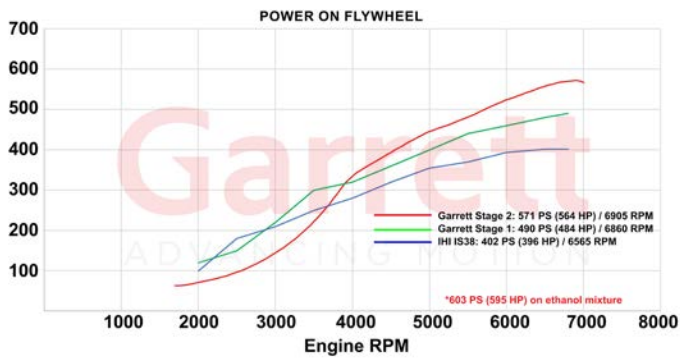

Make	Model	Year	Body & Trim	Engine	OEM Turbo
Audi	TT	2014 +	Base	2.0L L4 - Gas	IS20
Audi	TTS	2014 +	Base	2.0L L4 - Gas	IS38
Audi	A3	2015 - 18	Premium, Premium Plus, Prestige	2.0L L4 - Gas	IS20
Audi	A3 Quattro	2015 - 18	Premium, Premium Plus, Prestige	2.0L L4 - Gas	IS20
Audi	S3	2015 - 18	Premium Plus, Prestige	2.0L L4 - Gas	IS38
VW	Golf	2015	S, SE, SEL, Launch Edition	2.0L L4 - Gas	IS12
VW	Golf GTI	2015	Autobahn, S, SE	2.0L L4 - Gas	IS20
VW	Golf R	2015	Base	2.0L L4 - Gas	IS38
VW	Golf	2016	Base, S, SE, SEL	2.0L L4 - Gas	IS12
VW	Golf GTI	2016	Autobahn, S, SE	2.0L L4 - Gas	IS20
VW	Golf R	2016	Base	2.0L L4 - Gas	IS38
VW	Golf	2017	S, Wolfsburg Edition	2.0L L4 - Gas	IS12
VW	Golf Alltrack	2017	S, SE, SEL	2.0L L4 - Gas	IS12
VW	Golf GTI	2017	Autobahn, S, SE	2.0L L4 - Gas	IS20
VW	Golf R	2017	Base	2.0L L4 - Gas	IS38
VW	Golf	2018	S, SE, SEL	2.0L L4 - Gas	IS12
VW	Golf Alltrack	2018	S, SE, SEL	2.0L L4 - Gas	IS12
VW	Golf GTI	2018	Autobahn, S, SE	2.0L L4 - Gas	IS20
VW	Golf R	2018	Base	2.0L L4 - Gas	IS38
Audi	TT	2014-2018	Base	2.0L L4 - Gas	IS20
Audi	TT Quattro	2014-2018	Base	2.0L L4 - Gas	IS20
Audi	TTS Quattro	2014-2018	Base	2.0L L4 - Gas	IS38
Audi	S3	2013 - 16	Base	2.0L L4 - Gas	IS38
Audi	S3 (facelift)	2016 - 17	Base	2.0L L4 - Gas	IS38
Audi	SQ2 Quattro	2018-2020	Base	2.0L L4 - Gas	IS38
Seat	Leon Cupra	2014-2016	Base	2.0L L4 - Gas	IS20
Seat	Leon Cupra	2014-2018	280, 290	2.0L L4 - Gas	IS38
Seat	Leon Cupra (facelift)	2018-2020	290, 300, R	2.0L L4 - Gas	IS38
Cupra	Ateca	2018-2020	Base	2.0L L4 - Gas	IS38
Skoda	Octavia RS	2013-2016	Base	2.0L L4 - Gas	IS20
Skoda	Octavia RS (facelift)	2017-2020	Base	2.0L L4 - Gas	IS20
Skoda	Superb 4x4	2015-2019	Style, Ambition, SportLine	2.0L L4 - Gas	IS38
VW	Golf GTI	2013-2016	Base, Performance	2.0L L4 - Gas	IS20
VW	Golf R	2013-2016	Base	2.0L L4 - Gas	IS38
VW	Golf GTI	2016	Clubsport	2.0L L4 - Gas	IS38
VW	Golf GTI (facelift)	2017-2019	Base, Performance	2.0L L4 - Gas	IS20
VW	Golf GTI (facelift)	2019	TCR	2.0L L4 - Gas	IS38
VW	Golf R (facelift)	2017-2019	Base	2.0L L4 - Gas	IS38
VW	Passat 4MOTION	2018-2019	Base, Highline	2.0L L4 - Gas	IS38
VW	Arteon 4MOTION	2018-2020	Elegance, R-Line	2.0L L4 - Gas	IS38

O/E Turbocharger Part Numbers

European Applications

IS12 06K124713L
 IS20 06K145874M
 IS38 06K145722H



WARNING: Maximum allowable turbocharger speed is 185krpm (Stage 1) and 165krpm (stage 2). The use of this product above max turbocharger speed is at the owner's risk, and can result in damage and premature failure. To protect the turbocharger from overspeed when operating, a speed sensor port is machined into the compressor housing for the fitment of speed sensor part numbers 781328-0003 (includes sensor and gauge), and 781328-0004 (includes speed sensor). Speed sensors sold separately.



POWERMAX™ DIRECT FIT PERFORMANCE TURBOCHARGER

Application: 2020+ Volkswagen Golf R | Audi | Cupra | 2.0L TSI EA888 EVO4 Engine

Part Number: 921474-5001S Supports up to 550BHP (410kW)

[Introducing the 2020+ Garrett PowerMax direct-fit turbocharger](#), the ultimate performance boost for your 2.0L TSI EA888 EVO4 engine. Whether you drive an Audi A3, a Golf R, or a Cupra Formentor, this upgrade will boost your driving experience to the next level.

This direct-fit turbocharger upgrade produced a stunning 520BHP (383kW) and 425ft-lb of torque (576Nm) on a conservative tune on the dyno. During flow testing, this performance turbocharger supplied +20% compressor flow, and +37% turbine flow compared to the OE turbo. Garrett's latest generation of compressor and turbine wheel technology provide maximum flow and efficiency to this turbocharger, all within the OEM footprint.

But that's not all. The turbine wheel is constructed of Mar-M alloy rated for temperatures up to 1050°C. The stainless steel, internally wastegated turbine housing is also rated for temperatures up to 1050°C, ensuring durability and reliability under extreme conditions. Additionally, the turbine housing wastegate channel has been optimized for higher flow and performance control. The PowerMax turbocharger also comes with a fully machined speed sensor port so you can track turbo speed in your data logger or in Garrett's new [G-Smart Bluetooth Module \(sold separately PN 923586-0003\)](#).

**Please refer to the legal notice on page 114 before purchasing this product.*

Turbocharger Reference Data:

Part Number	Power	Model	Comp Ind	Comp Exd	Turb Ind	Turb Exd
921474-5001S	550BHP 410kW	GT2563	51mm	63mm	58mm	50mm

Vehicle Applications:

Make	Model	Region	Year	Engine	OEM Turbo
VW	Golf R	North America	2022+	EA888 EVO4 - Gas	06Q145703C (EU) 06Q145703F 06Q145703G 06Q145703H
VW	Golf VIII GTI Clubsport		2020+		
	T-ROC R 4Motion		2022+		
	Golf VIII R 4Motion		2020+		
	Golf VIII Variant TSI R 4Motion		2021+		
	Tiguan TSI R 4Motion		2020+		
Audi	A3 Limousine S3 Quattro		2020+		
	A3 Sportback S3 Quattro		2020+		
	SQ2		2021+		
	TTS Quattro		2021+		
	Roadster TTS Quattro	2020+			
Cupra	Formentor 2.0 TSI 4Drive	2020+			
	Leon Sportstourer 2.0 TSI 4Drive	2021+			
	Leon Sportstourer 2.0 TSI	2021+			
	Leon 2.0 TSI	2021+			
	Ateca 2.0 TSI 4Drive	2020+			

* Performance results of this product are highly dependent upon your vehicle's modifications and tuning/calibration. The horsepower numbers represented above are based on actual on-vehicle testing.

Compressor Map

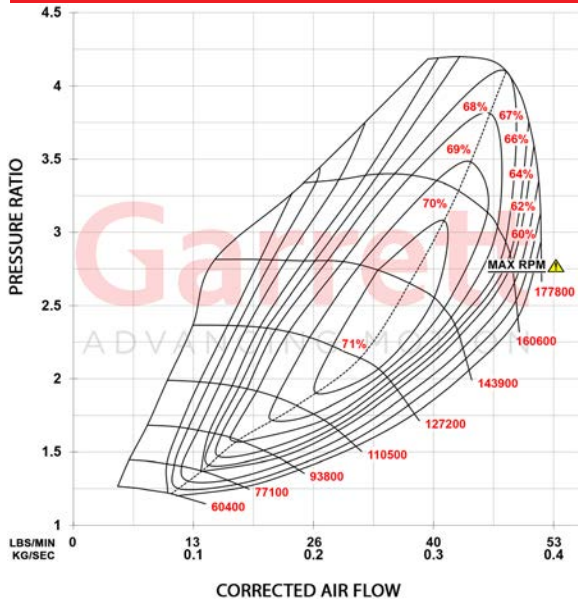

Exhaust Flow Chart

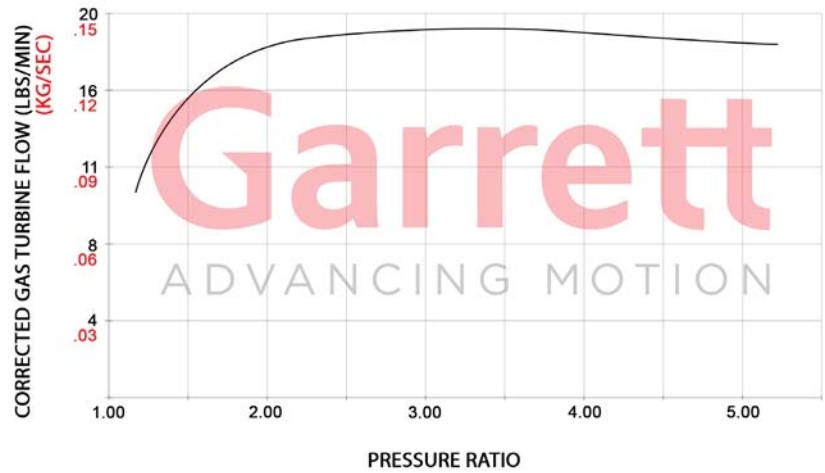

Features

- Complete assembly with calibrated electric actuator for OE fitment
- 550BHP | 410kW turbo capability (on-vehicle results 520BHP | 383kW - with conservative tune)
- +20% compressor flow compared to OE turbo
- +37% turbine flow compared to OE turbo
- Customized modern compressor wheel aero for application
- Modern gasoline turbine wheel aerodynamics constructed of Mar-M alloy rated for up to 1050°C
- Stainless steel turbine housing rated for up to 1050°C
- Fully machined speed sensor port
- Integrated thrust bearing - reinforced for application

On-Vehicle Test Data:

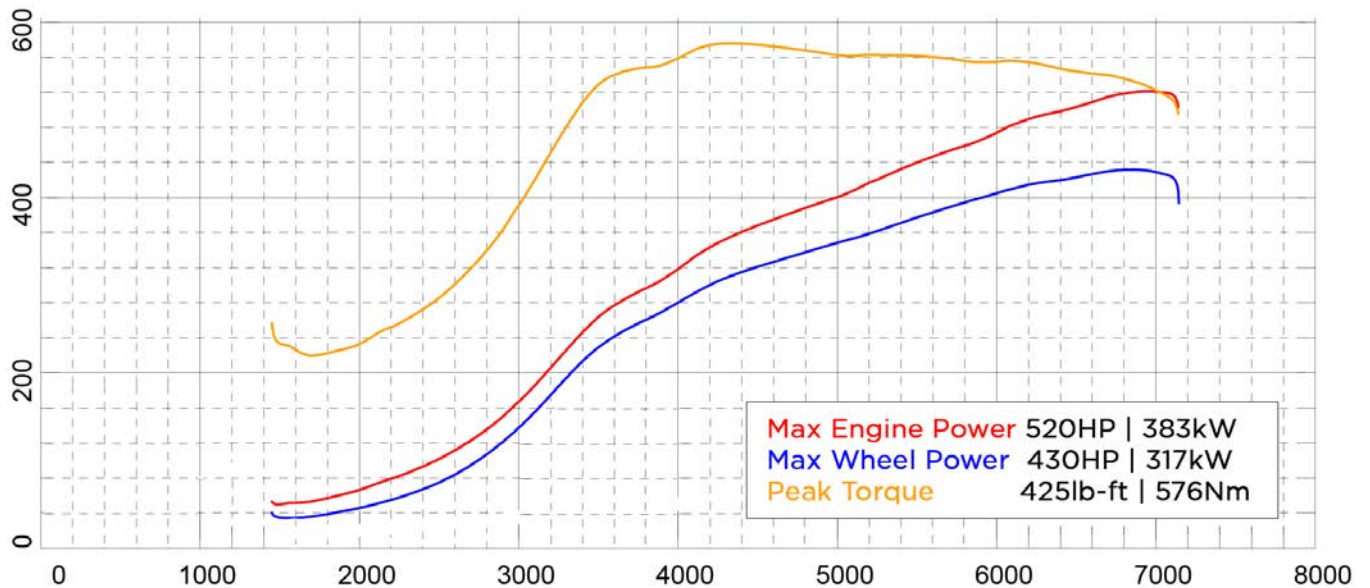

Vehicle Information:

- Location: Germany
- Golf R 2.0L TFSI (EA888 Evo4)
- Stock intercooler
- Custom downpipe
- Stock fuel system
- Fuel - 98 octane unleaded



WARNING: Maximum allowable turbocharger speed is 177.8krpm. The use of this product above max turbocharger speed is at the owner's risk, and can result in damage and premature failure. To protect the turbocharger from overspeed when operating, a speed sensor port is machined into the compressor housing for the fitment of speed sensor part numbers 781328-0003 (includes sensor and gauge), 781328-0004 (includes speed sensor), or [G-Smart Bluetooth Module with sensor \(PN 923586-0003\)](#). Sensor Kits sold separately.

* Performance results of this product are highly dependent upon your vehicle's modifications and tuning/calibration. Horsepower numbers represented above are based on actual on-vehicle testing.



POWERMAX™ DIRECT FIT PERFORMANCE TURBOCHARGER

Application: 2020+ Volkswagen | Audi | Skoda | Cupra | Seat 2.0L EA888 Engine
Part Number: 917056-5002S Supports up to 447BHP (333kW)

Introducing the Garrett PowerMax™ turbocharger upgrade for the 2.0L EA888 Evo4 engine platform. Engineered by enthusiasts, for enthusiasts, this turbocharger upgrade isn't just about boosting your engine's capabilities, it's also about packaging it into your vehicle's existing OEM setup. This complete turbocharger with electronic actuator can help the engine produce up to an impressive 447BHP (333 kW), as proven by on-vehicle results.

GTX Gen II compressor aerodynamics increase turbocharger flow by a staggering 32% compared to the OEM turbo. Embrace the future of power with the high-temperature Mar-M alloy turbine wheel, paired with state-of-the-art turbine aerodynamics and a robust twin scroll stainless steel turbine housing capable of withstanding up to 1050°C of heat. Elevate your driving game, and experience performance like never before with PowerMax™.

**Please refer to the legal notice on page 114 before purchasing this product.*



Part Number	Power	Model	Comp Ind	Comp Exd	Turb Ind	Turb Exd
917056-5002S	447BHP (333kW)	GT2260S	47mm	60mm	50mm	45mm

Vehicle Applications:

Make	Model	Region	Year	Engine	OEM Turbo
VW	Golf GTI	Europe	2022+	2.0L EA888 Evo4 L4 - Gas	06Q145702B
VW	Golf GTI		2020+		
VW	Tiguan 2.0 TSI		2020+		
Audi	Q3 45 TFSI 2.0		2021+		
Audi	TT 45 TFSI 2.0		2020+		
Skoda	Kodiaq RS TSI 4x4		2021+		
Skoda	Octavia RS		2020+		
Cupra	Leon 2.0 TSI		2021+		
Cupra	Formentor 2.0 TSI		2021+		
Seat	Tarraco 2.0 TSI		2021		

• Garrett is the OEM turbocharger for this application. For regions and applications not listed above please reference the OEM turbo part number for fitment.

* Performance results of this product are highly dependent upon your vehicle's modifications and tuning/calibration. The horsepower numbers represented above are based on actual on-vehicle testing.

Compressor Map

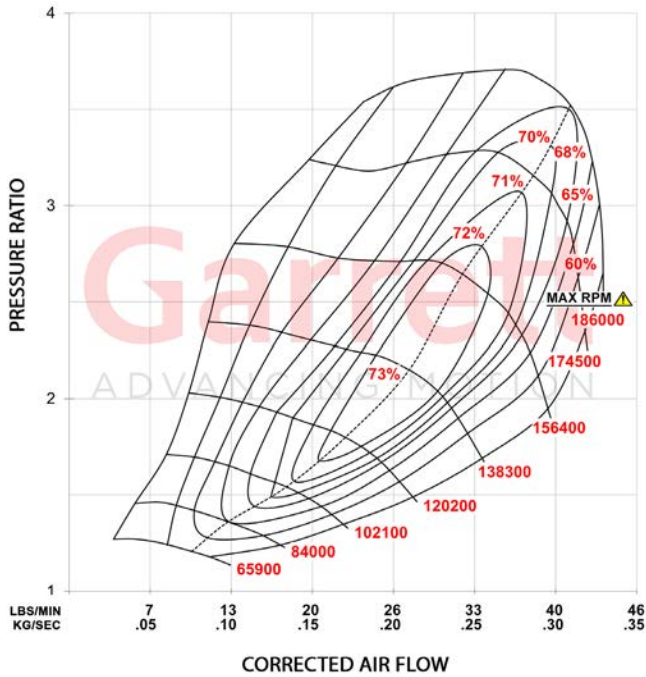

Exhaust Flow Chart

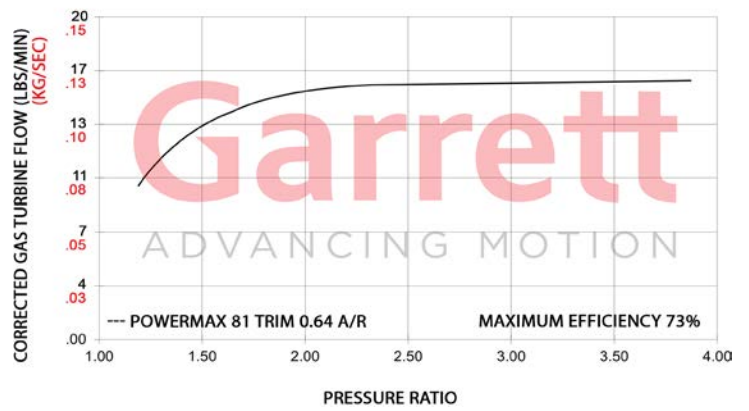

Features:

- Complete assembly with electronic actuator
- +32% compressor flow compared to the OEM turbo
- GTX Gen II compressor aerodynamics
- Mar-M alloy turbine wheel and twin scroll stainless steel turbine housing rated up to 1050° C
- Latest generation of journal bearing rotating group with 360° reinforced thrust bearing
- Direct-fit turbo with 447BHP (333kW) capability (on-vehicle results)*
- +50% turbine flow compared to OEM turbo

On-Vehicle Test Data: VW Golf GTI 2.0L TFSI (EA888 Evo4)

Vehicle Modifications:

- Location: Germany
- GTI 2.0L TFSI (EA888 Evo4)
- 917056-5002S Turbocharger
- Stock intercooler
- Custom downpipe
- Stock fuel system
- Fuel - 98 octane unleaded

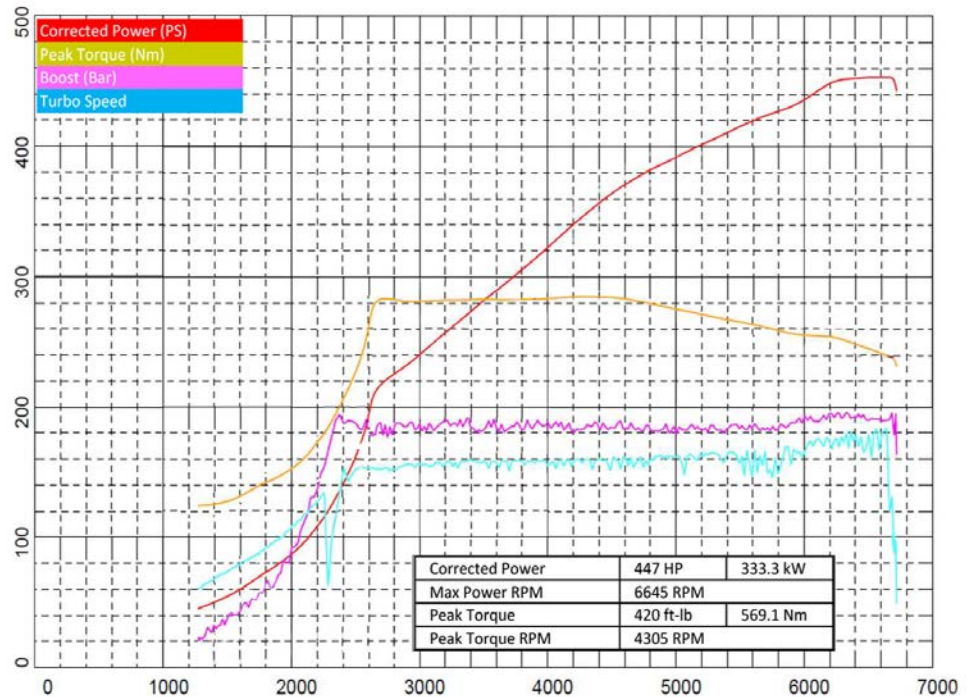

WARNING: Maximum allowable turbocharger speed is 186krpm. The use of this product above max turbocharger speed is at the owner's risk, and can result in damage and premature failure. To protect the turbocharger from overspeed when operating, a speed sensor port is machined into the compressor housing for the fitment of speed sensor part numbers 781328-0003 (includes sensor and gauge), and 781328-0004 (includes speed sensor). Speed sensors sold separately.



POWERMAX™ DIRECT FIT PERFORMANCE TURBOCHARGER

Applications: Stage 1 Turbo Upgrade For Ford 2.0L EcoBoost (2013 - 2018) Focus ST | Escape | Kuga | Fusion | Taurus | Lincoln
Part Number: 886195-5001S

The Garrett PowerMax™ Stage 1 turbocharger upgrade for the 2013 - 2018 2.0L Ford EcoBoost engine platform is engineered to increase engine performance capability while maintaining OEM installation specifications. This direct drop-in turbocharger provides up to 16% more flow than OEM and will support up to 350 BHP* (260kW). Improvements in compressor efficiency and flow can be attributed to the 52mm fully-machined compressor wheel with advanced aero design. Inconel alloy turbine wheel and stainless steel turbine housings are rated for up to 950° C. This turbocharger kit comes fully assembled, calibrated, and is outline interchangeable with the OE hardware to ensure a perfect fit every time. Contact your local authorized Garrett® distributor for additional information and pricing.

**Please refer to the legal notice on page 114 before purchasing this product.*

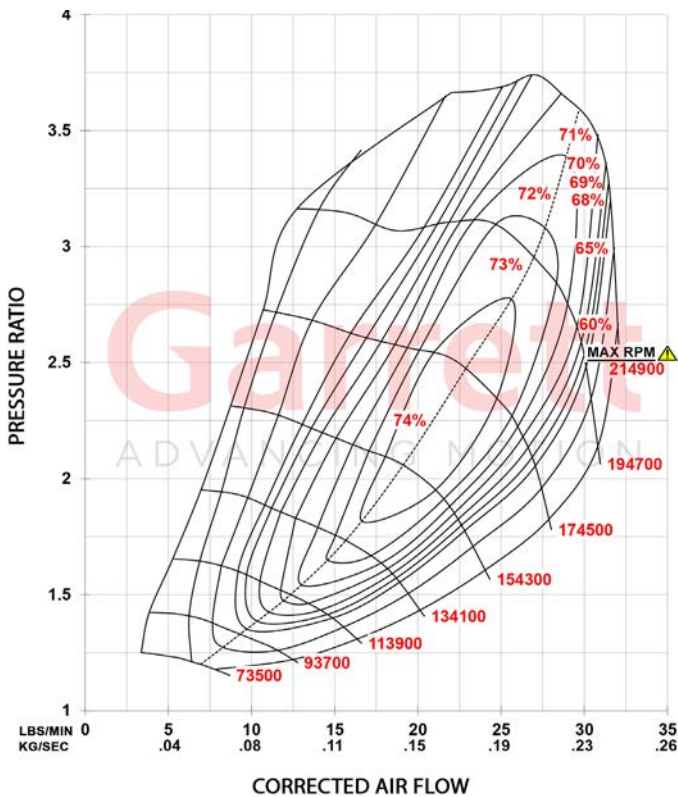

Part Number		886195-5001S
Model	Year	Body & Trim
Escape / Kuga	2014 - 2016	SE, Titanium
Focus	2013 - 2018	ST
Fusion	2013 - 2016	SE, Titanium
Police Sedan	2014 - 2018	Base
Taurus	2013 - 2017	Limited, SE, SEL
MKC	2015 - 2017	Base, Black Label, Premiere, Reserve, Select
MKT	2016	Base
MKZ	2013 - 2016	Base, Black Label
Engine	Type	2.0L EcoBoost
	Fuel	Gas
	Cylinders	4



WARNING: Maximum allowable turbocharger speed is 214.9krpm. The use of this product above max turbocharger speed is at the owner's risk, and can result in damage and premature failure. To protect the turbocharger from overspeed when operating, a speed sensor port is machined into the compressor housing for the fitment of speed sensor part numbers 781328-0001 (includes sensor and gauge), and 781328-0002 (includes speed sensor). Speed sensors sold separately.

* Estimated Horsepower. Performance results of this product are highly dependent upon your vehicle's modifications and tuning/calibration. The horsepower numbers represented above are calculated based strictly on choke flow of the compressor map (total turbo capability), which represents the potential flywheel horsepower.



POWERMAX™ DIRECT FIT PERFORMANCE INTERCOOLER

Application: 2013 - 2018 2.0L Ford Focus ST

Part Number: 880736-6001

The Garrett direct fit Ford Focus ST performance charge air cooler boasts a 115% larger core that helps reduce intake manifold temperatures by an average of 11 °F (6.1 °C) based on OBD II data. Optimized end tanks improve air flow through the core. This performance intercooler showed an increase of up to 25 HP (19 kW) and 9 lb-ft (12 N-m) of torque compared to OE during back to back dyno comparisons in a wind tunnel which generates air velocity that matches vehicle speed. During testing the heat saturation point increased from 4 dyno pulls to 8 dyno pulls.

This direct fit performance intercooler installs in 1.5 hour and reuses the stock bolts, hoses, and clamps. Removal of the OE grill shutters required. For more information including Installation instructions please visit our website: www.garrettmotion.com/racing-and-performance/performance-catalog/intercoolers/

Features:

- Supports up to 670 HP (499 kW)
- 115% larger core than stock
- Installs in stock location
- Up to 25 HP (19 kW) and 9 lb-ft (12 N-m) of torque
- Average 11 °F (6.1 °C) reduction in intake temperature based on OBD II data
- Integrated drain plug to evacuate condensation
- Cast aluminum end tanks
- Advanced offset fin design
- Bar-and-plate construction

Part Number		880736-6001
Vehicle	Make	Ford
	Model	Focus ST
	Year	2013-2018
Engine	Type	2.0L
	Fuel	Gas
Weight	23 lbs / 10.4 kg	
Size Specs	26.3" x 4.3" x 7.8"	
	668mm x 109mm x 198mm	

*** Important:** For customers outside of North America, MAP sensor BV61-9F479-AA must be purchased separately and used for installation to ensure a proper fit





POWERMAX™ DIRECT FIT PERFORMANCE INTERCOOLER

Application: 2011-2021 Ford Ranger PX1 PX2 PX3 | Everest | 2011-2020 Mazda BT-50

Part Number: 881649-6001

The Garrett direct fit performance charge air cooler for the Ford Ranger and Mazda BT50 boasts a 218% larger core that helps reduce intake manifold temperatures by an average of 32 °C based on test data. Optimized end tanks improve air flow through the core. This direct fit performance intercooler installs in 2.0 hours and reuses the stock bolts, hoses, and clamps.

This direct fit performance intercooler installs in 1.5 hour and reuses the stock bolts, hoses, and clamps. Removal of the OE grill shutters required. For more information including Installation instructions please visit our website: www.garrettmotion.com/racing-and-performance/performance-catalog/intercoolers/

Features:

- Supports up to 499 kW
- 218% larger core than stock
- Installs in stock location
- Cast aluminum end tanks
- Advanced offset fin design
- Bar-and-plate construction

Part Number		881649-6001	
Vehicle	Make	Ford	Mazda
	Model	Ranger PX1 PX2 PX3 Everest	BT-50
	Year	2011-2021	2011-2020
Engine	Type	3.2L 2.2L 2.0L	
	Fuel	Diesel	
Weight	12.56 kg		
Size Specs	680mm x 101mm x 260mm		



*** Important:** For applications outside of Australia, please contact your local distributor to ensure drop-in fitment as products may need modification or additional hoses/clamps.



POWERMAX™ DIRECT FIT PERFORMANCE TURBOCHARGER

Applications: Stage 1 Turbo Upgrade for 2011-2021 Ford Ranger PX1 PX2 PX3 | Everest | 2011-2020 Mazda BT-50
Supports up to 172kW*

Part Number: 880862-5001W

This Garrett PowerMax™ direct fit turbocharger is designed for the 3.2L Duratorq 5 cylinder diesel engine platform found in the 2011-2021 Ford Ranger PX1 PX2 PX3 | Everest and the 2011-2020 Mazda BT-50. The forged, fully machined compressor wheel designed for the GTX Gen II product line increases flow by 20% over the OE wheel. With the correct engine calibration, this enables the engine to be tuned up to 172kW from OE standard 147kW. All Garrett PowerMax™ direct fit turbochargers are outline interchangeable with the OE turbocharger ensuring a perfect fit every time.

**Please refer to the legal notice on page 114 before purchasing this product.*

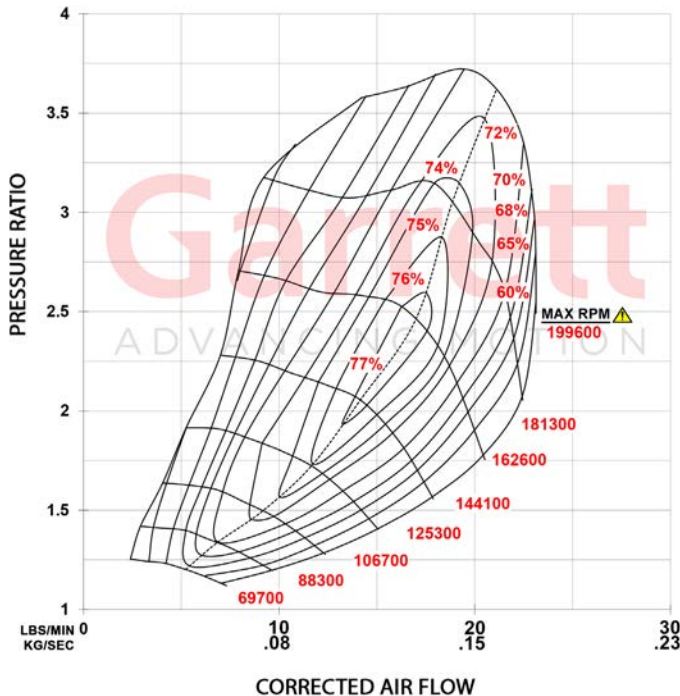

Part Number		880862-5001W **	
Turbo	Replaces OEM part numbers	798166-0006 (5006S) 812971-0006 (5006S) 853333-5001S	
	Vehicle	Make	Ford Mazda
		Model	Ranger PX1 PX2 PX3 Everest BT-50
Engine	Year	2011 - 2021	2011 - 2020
	Type	Duratorq 3.2 / Powerstroke 3.2	
	Fuel	Diesel	
	Emissions	Euro V	
	Cylinders	5	

** Includes gasket kit

Features:

- GTX Gen II compressor wheel aerodynamics
- Wider compressor map for improved performance
- 20% more flow than the OE turbocharger



WARNING: Maximum allowable turbocharger speed is 199.6krpm. The use of this product above max turbocharger speed is at the owner's risk, and can result in damage and premature failure. To protect the turbocharger from overspeed when operating, a speed sensor port is machined into the compressor housing for the fitment of speed sensor part numbers 781328-0001 (includes sensor and gauge), and 781328-0002 (includes speed sensor). Speed sensors sold separately.

* Estimated Horsepower. Performance results of this product are highly dependent upon your vehicle's modifications and tuning/calibration. The horsepower numbers represented above are calculated based strictly on choke flow of the compressor map (total turbo capability), which represents the potential flywheel horsepower.



POWERMAX™ DIRECT FIT PERFORMANCE INTERCOOLER

Application: 2015+ Ford F-150 and Raptor 3.5L EcoBoost
Supports Up To 750 Horsepower | C.A.R.B Certified ✓
Part Number: 870702-6001

The Garrett direct fit F-150 charge air cooler boasts an 83% larger core than stock to provide up to 40 °F reduction in air temperature and up to 30% reduction in pressure drop. Optimized end tanks improve air flow through the core. This direct fit performance intercooler is easily installed and can support up to 750 horsepower all while reusing the stock bolts, hoses, and clamps.

This direct fit performance intercooler installs in 2.5 hours and reuses the stock bolts, hoses, and clamps. Removal of the OE grill shutters required. For more information including Installation instructions please visit our website: www.garrettmotion.com/racing-and-performance/performance-catalog/intercoolers/

Features:

- Supports up to 750 horsepower
- C.A.R.B Certified (EO# D-794)
- 83% larger core than stock
- Installs in stock location
- +16 horsepower at temperature saturation
- Up to 40 °F reduction in temperature
- Integrated drain plug to evacuate condensation

Part Number		870702-6001
Vehicle	Make	Ford
	Model	F-150
	Year	2015+
Engine	Type	3.5L / 2.7L
	Fuel	Gas
Size Specs	21" x 5.32" x 9.43"	





POWERMAX™ DIRECT FIT PERFORMANCE TURBOCHARGER

Application: Stage 1 Turbo Upgrade For 1.9L | 2.0L VW TDI Engines

VW 1.9L TURBO UPGRADE

Part Number: 778445-5002S 1.9L (175hp*)

The Garrett GT1749V is the first performance upgrade / replacement turbocharger available to the aftermarket for Volkswagen 1.9L TDI BEW Engines. The GT1749V comes equipped with a smart actuator, an industry exclusive, and a position sensor, which enables the turbocharger to communicate automatically with the Engine Control Unit (ECU). The kit is easy to install and suitable as a performance upgrade or replacement turbocharger. The Garrett VW TDI Kit also promotes a longer turbo and engine life span and increased reliability by lowering exhaust gas temperatures.

VW 2.0L TURBO UPGRADE

Part Number: 838946-5001S 2.0L (190hp*)

The Garrett GTA1749V is a performance upgrade / replacement turbocharger available to the Aftermarket for Volkswagen 2.0L TDI BKD/BKP/AZV engines. The GTA1749V comes equipped with a larger compressor wheel for increased flow and bolts directly to the stock engine manifold flange. The turbo is easy to install and suitable as a performance upgrade or replacement turbocharger. The Garrett VW TDI turbo also promotes a longer turbo and engine life span and increased reliability by lowering exhaust gas temperatures.

**Please refer to the legal notice on page 114 before purchasing this product.*

Volkswagen TDI 1.9L 2.0L Upgrade	Turbo PN	HP*	Compressor				Turbine			
			Inducer	Exducer	Trim	A/R	Inducer	Exducer	Trim	A/R
VW 1.9L TDI (BEW Engine) VNT	778445-5002S	175	36mm	49mm	55	0.46	43mm	38mm	76	0.61
VW 2.0L TDI (BKD Engine) VNT	838946-5001S	190	36mm	49mm	55	0.46	43mm	36mm	70	0.61

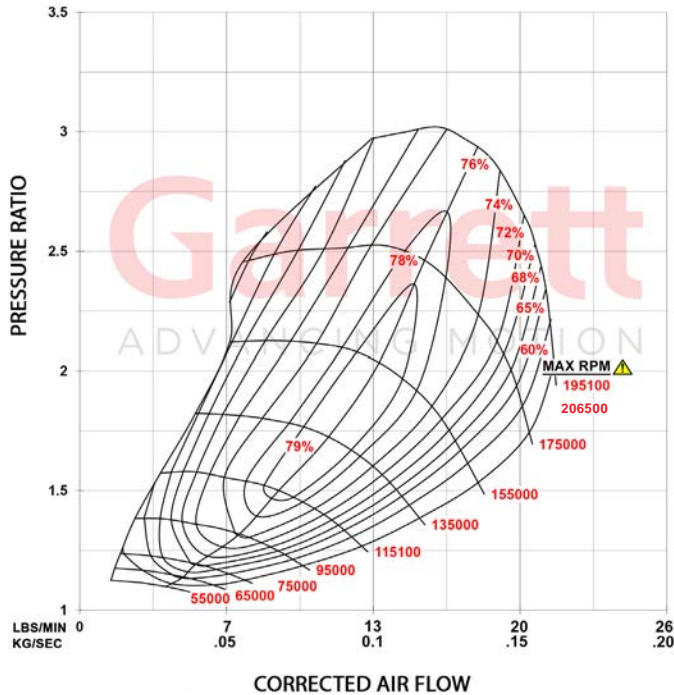

Replaces VW OE Part Numbers: 03G 253 010 J & 03G 253 010 J V100

- Vehicles: 2.0L TDI BKD/BKP/AZV engines
 2003.10-2009.07 – Golf V Mk5 A5 (PQ35) (typ 1K)
 2005.08-2011.05 – Jetta A5 (PQ35) (typ 1K)
 2003.08-2010.05 – Touran (typ 1T) – [AZV for 136 HP]
 2005.09-2010.05 – Passat B6 (typ 1T) – BKP
 2004.02-2010.05 – Skoda Octavia Mk2 (typ 1Z)
 2nd gen. [AZV fo 136HP]
 2009.01-2010.03 – Skoda Superb B6 (typ 3T)
 [BKD EA188]
 2005.07-2011.09 – Leon Mk2 (typ 1P)
 2004.03-2011.09 – Seat Altea
 2004.04-2009.05 – Seat Toledo 3
 2003.08-2007.05 – Audi A3 (Typ 8P)

Replaces VW OE Part Numbers: 038 253 019 S & 038 253 014 E Model: KP39 (3K)

- Vehicles: 2003.05 - 2006 Volkswagen Beetle TDI
 2003.05 - 2006 Volkswagen Golf TDI
 2003.05 - 2005 Volkswagen Jetta TDI



WARNING: Maximum allowable turbocharger speed is 206.5krpm. The use of this product above max turbocharger speed is at the owner's risk, and can result in damage and premature failure. To protect the turbocharger from overspeed when operating, a speed sensor port can be machined into the compressor housing for the fitment of speed sensor part numbers 781328-0001 (includes sensor and gauge), and 781328-0002 (includes speed sensor). Speed sensors sold separately.

* Estimated. Performance results of this product are highly dependent upon your vehicle's modifications and tuning/calibration. The horsepower numbers represented above are calculated based strictly on choke flow of the compressor map (total turbo capability), which represents the potential flywheel horsepower.

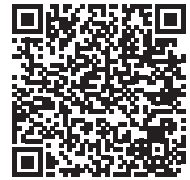

POWERMAX™ DIRECT FIT PERFORMANCE TURBOCHARGER

Application: Stage 1 | 2 Turbo Upgrade For 2004.5 - 2009 6.6L Duramax Engines

Stage 1 | 2004.5-2009 Chevy / GMC 2500, 3500
Part Number 773540-5001s (590HP*)

The Duramax Stage 1 turbocharger kit features Garrett patented Advanced Variable Nozzle Turbine AVNT™ design for increased compressor and turbine flow. The GT Series wheel design ensures top performance, lower back pressure and reduces intake and exhaust gas temperatures. The unique design features nine movable vanes which significantly increase turbine efficiency and improve engine performance from idle launch through peak torque. Patented integral electro-hydraulic actuation and proportional solenoid allow for infinitely variable control. Suitable as a performance upgrade or replacement for original equipment. Outline interchangeable with the OE turbo for a perfect fit each and every time.

Stage 2 | 2004.5-2009 Chevy / GMC 2500, 3500
Part Number 773542-5001s (630HP*)

The Duramax Stage 2 turbocharger kit features Garrett patented Advanced Variable Nozzle Turbine AVNT™ design for increased compressor flow and turbine flow. Utilizes nine movable vanes which significantly increase turbine efficiency and improve engine performance from idle launch through peak torque. Patented integral electro-hydraulic actuation and proportional solenoid for infinitely variable control. Larger compressor trim (52), plus larger GT40 turbine wheel and vanes. Outline interchangeable with the OE turbo for a perfect fit each and every time.

**Please refer to the legal notice on page 114 before purchasing this product.*

Chevy GMC Duramax Upgrade	Turbo PN	HP*	Compressor				Turbine			
			Inducer	Exducer	Trim	A/R	Inducer	Exducer	Trim	A/R
Duramax 6.6L 2004.5-2009 Stage 1	773540-5001S	590	65mm	94mm	48	0.58	73mm	67mm	78	0.90
Duramax 6.6L 2004.5-2009 Stage 2	773542-5001S	630	68mm	94mm	52	0.58	77mm	68mm	79	0.90

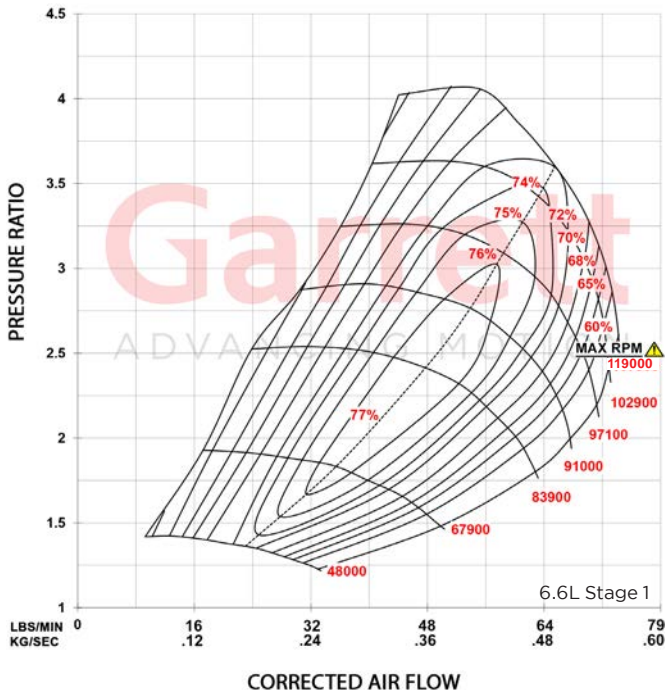

WARNING: Maximum allowable turbocharger speed is 119krpm. The use of this product above max turbocharger speed is at the owner's risk, and can result in damage and premature failure. To protect the turbocharger from overspeed when operating, a speed sensor port can be machined into the compressor housing for the fitment of speed sensor part numbers 781328-0001 (includes sensor and gauge), and 781328-0002 (includes speed sensor). Speed sensors sold separately.

* Estimated. Performance results of this product are highly dependent upon your vehicle's modifications and tuning/calibration. The horsepower numbers represented above are calculated based strictly on choke flow of the compressor map (total turbo capability), which represents the potential flywheel horsepower.



POWERMAX™ DIRECT FIT PERFORMANCE TURBOCHARGER

Application: Stage 1 Turbo Upgrade For (2014 - 2019) General Motors (Holden, Chevrolet) Colorado 2.8L XLDE
Part Number: 892179-5001S

Garrett PowerMax™ turbocharger upgrade for the Chevrolet Duramax 2.8L engine platform is engineered to increase engine performance while maintaining OEM installation specifications. This direct drop-in stage 1 upgrade provides up to 20% more flow than OEM and will support up to 160kW/ 215 BHP*. Variable turbine geometry is engineered to factory OEM specs and is controlled by the included module. Improvements in efficiency and flow can be attributed to the lightweight forged fully-machined compressor wheel with advanced aero design. This turbocharger is outline interchangeable with the OE hardware to ensure a perfect fit every time.

Contact your local authorized Garrett distributor for additional information and pricing.

**Please refer to the legal notice on page 114 before purchasing this product.*

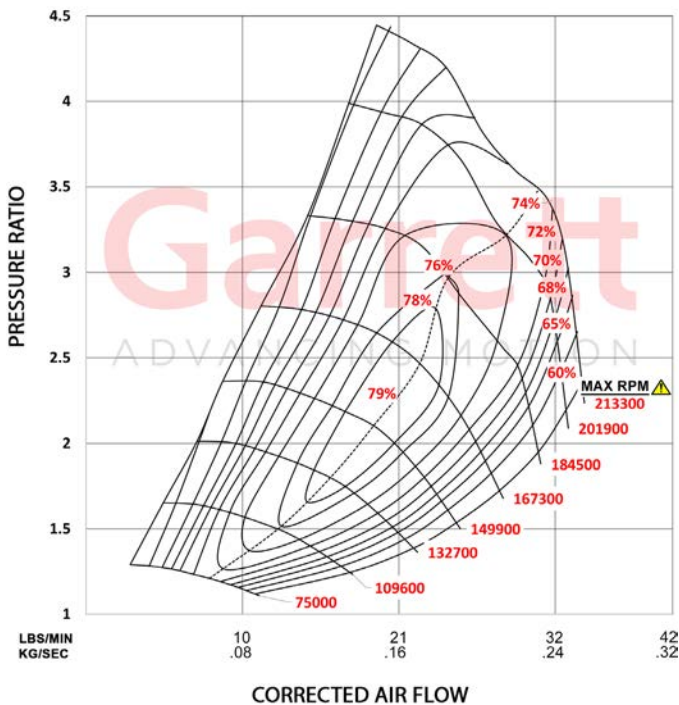

Part Number		892179-5001S
Turbo	Model	GTB1752V
	Comp Inducer	42mm
	Replaces OEM part numbers	814067-0005
		814067-0004
814067-0003		
Vehicle	Model	Colorado Colorado 7
	Year	2014 - 2019
Engine	Type	2.8L XLDE
	Fuel	Diesel
	Emission Regulation	Euro 3,4,5
	Cylinders	I4
	Horsepower	160kW / 215BHP*



WARNING: Maximum allowable turbocharger speed is 213.3krpm. The use of this product above max turbocharger speed is at the owner's risk, and can result in damage and premature failure. To protect the turbocharger from overspeed when operating, a speed sensor port is machined into the compressor housing for the fitment of speed sensor part numbers 781328-0001 (includes sensor and gauge), and 781328-0002 (includes speed sensor). Speed sensors sold separately.

* Estimated Horsepower. Performance results of this product are highly dependent upon your vehicle's modifications and tuning/calibration. The horsepower numbers represented above are calculated based strictly on choke flow of the compressor map (total turbo capability), which represents the potential flywheel horsepower.



POWERMAX™ DIRECT FIT PERFORMANCE TURBOCHARGER

Application: Stage 1 Turbo Upgrade For 2007 - 2018 Toyota Land Cruiser 4.5L 1VD-FTV

Part Number 881604-5001S

Supports up to 164kW*

This Garrett PowerMax™ direct fit turbocharger is designed for the 4.5L 1VD-FTV VS diesel engine platform found in the 2007-2018 Toyota Land Cruiser. The forged, fully machined compressor wheel designed for the G-Series product line increases flow by 20% over the OE wheel. Performance results of this product are highly dependent upon your vehicle's modifications and tuning. The power represented above was recorded on a chassis dyno with a modified ECU and OEM fuel delivery system enabling the engine to produce 164kW from the OE standard 151kW. All Garrett PowerMax™ direct fit turbochargers are outline interchangeable with the OE turbocharger ensuring a perfect fit every time.

**Please refer to the legal notice on page 114 before purchasing this product.*

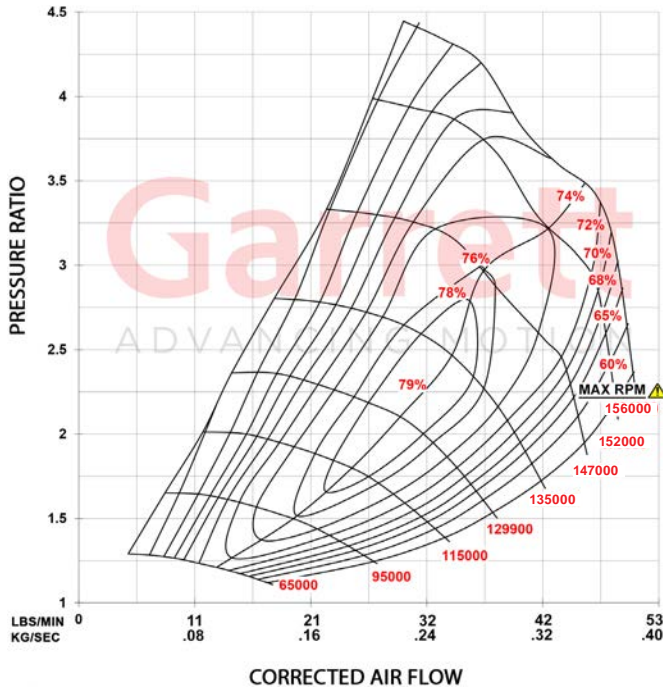

Part Number		881604-5001S
Turbo	Model	GTA2359V
	Interchangeable with OE PN	775095-0001 (5001S) 842127-0001 (5001S)
	Make	Toyota
Vehicle	Model	Land Cruiser
	Year	2007-2018
	Type	4.5 L 1VD-FTV V8
Engine	Fuel	Diesel
	Emissions	Euro IV
	Cylinders	8

Features:

- G-Series compressor wheel aerodynamics
- Wider compressor map for improved performance
- 20% more flow than the OE turbocharger
- VNT variable geometry technology



WARNING: Maximum allowable turbocharger speed is 156krpm. The use of this product above max turbocharger speed is at the owner's risk, and can result in damage and premature failure. To protect the turbocharger from overspeed when operating, a speed sensor port is machined into the compressor housing for the fitment of speed sensor part numbers 781328-0001 (includes sensor and gauge), and 781328-0002 (includes speed sensor). Speed sensors sold separately.

* Estimated Horsepower. Performance results of this product are highly dependent upon your vehicle's modifications and tuning/calibration. The horsepower numbers represented above are calculated based strictly on choke flow of the compressor map (total turbo capability), which represents the potential flywheel horsepower.



POWERMAX™ DIRECT FIT PERFORMANCE TURBOCHARGER

Application: Stage 1 Turbo Upgrade For 2011 - 2016 6.6L Chevrolet / GMC 2500HD, 3500HD
Part Number 886976-5004S

Supports up to 600WHP*

This Garrett PowerMax™ turbocharger upgrade for the Chevrolet and GMC 6.6L LML engine platform is engineered to increase engine performance while maintaining OEM installation specifications. This direct drop-in stage 1 upgrade provides 19% more flow than OEM and will support up to 600WHP*. Improvements in efficiency and flow can be attributed to the lightweight forged fully-machined compressor wheel. Boost response of this PowerMax turbocharger compared to OEM has not been tested. This turbocharger is outline interchangeable with the OE hardware to ensure a perfect fit every time.

**Please refer to the legal notice on page 114 before purchasing this product.*

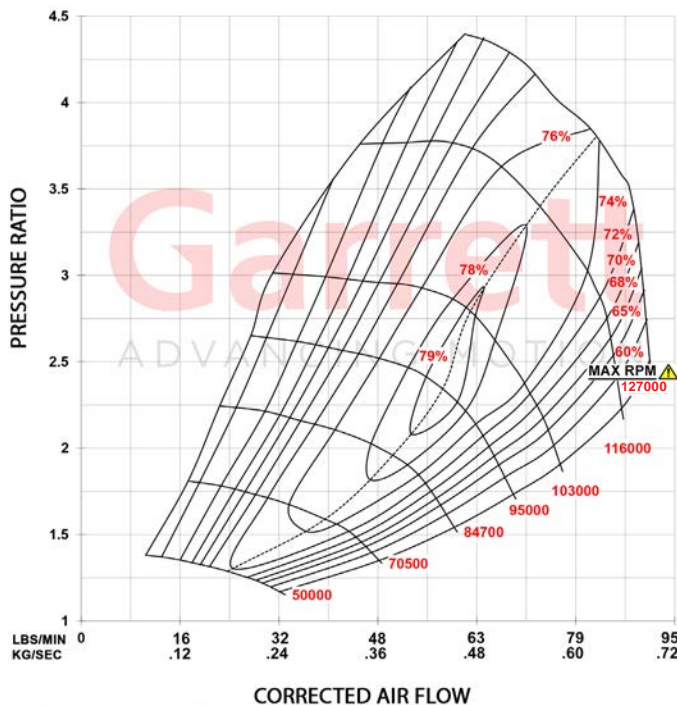

Part Number		886976-5004S
Turbo	Model	GT3788V
	Comp Ind	65mm
Vehicle	Make	Chevrolet GMC
	Model	2500HD 3500HD
	Year	2011 - 2016
Engine	Type	6.6L Duramax LML
	Fuel	Diesel
	Cylinders	8



WARNING: Maximum allowable turbocharger speed is 127krpm. The use of this product above max turbocharger speed is at the owner's risk, and can result in damage and premature failure. To protect the turbocharger from overspeed when operating, a speed sensor port can be machined into the compressor housing for the fitment of speed sensor part numbers 781328-0001 (includes sensor and gauge), and 781328-0002 (includes speed sensor). Speed sensors sold separately.

Available through the Master Distributors, Performance Distributors, and PowerMax™ Distributor networks.

* Estimated Horsepower. Performance results of this product are highly dependent upon your vehicle's modifications and tuning/calibration. The horsepower numbers represented above are calculated based strictly on choke flow of the compressor map (total turbo capability), which represents the potential flywheel horsepower.



7.3L Power Stroke



6.0L Power Stroke

POWERMAX™ DIRECT FIT PERFORMANCE TURBOCHARGER

Application: Stage 1 Turbo Upgrade For 7.3L | 6.0L Power Stroke Engines

*Please refer to the legal notice on page 114 before purchasing this product.

Ford Power Stroke Upgrade	Turbo PN	HP*	Compressor				Turbine			
			Inducer	Exducer	Trim	A/R	Inducer	Exducer	Trim	A/R
Power Stroke 7.3L 1999.5-2003	739619-5004S	590	66mm	88mm	56	1.00	76mm	68mm	79	1.00
Power Stroke 6.0L 2003 Stage 1	777469-5002S	560	64mm	88mm	52	0.58	73mm	66mm	84	0.90
Power Stroke 6.0L 2004-2007 Stage 1	772441-5002S	560	64mm	88mm	52	0.58	73mm	66mm	84	0.90

7.3L Power Stroke

Applications: 1999.5 - 2003 F250 | F350 | Excursion
Part Number 739619-5004s (590HP*)

The GTP38R turbocharger contains an exclusive ball bearing cartridge for unbeatable response, efficiency, and durability. Elimination of the thrust bearing eliminates failures at elevated boost levels. The 88mm GT compressor wheel provides 33% more flow than the stock 80mm wheel. A ported shroud housing improves compressor flow range for surge control. The kit includes a 1.00 A/R turbine housing for free flowing exhaust with reduced back pressure and up to 200° F reduction in exhaust gas temperature. Maximum recommended boost level is 40psi.

6.0L Power Stroke

Applications: 2003 Ford F-250 | F-350
Part Number 777469-5002S (560HP*)
Applications: 2004-2007 Ford F250 | F350 | Excursion
Part Number 772441-5002S (560HP*)

The GT3788VA Turbocharger features the Garrett patented Advanced Variable Nozzle. Turbine AVNT™ design for increased compressor flow and boost response. Utilizes nine movable vanes which significantly increase turbine efficiency and improve engine performance from idle launch through peak torque. Patented integral electro-hydraulic actuation and proportional solenoid for infinitely variable control. Larger compressor wheel over stock increases maximum power range while keeping turbo speeds down for the same power output.



WARNING: Maximum allowable turbocharger speed is 127krpm (7.3L) and 134krpm (6.0L). The use of this product above max turbocharger speed is at the owner's risk, and can result in damage and premature failure. To protect the turbocharger from overspeed when operating, a speed sensor port can be machined into the compressor housing for the fitment of speed sensor part numbers 781328-0001 (includes sensor and gauge), and 781328-0002 (includes speed sensor). Speed sensors sold separately.

* Estimated Horsepower. Performance results of this product are highly dependent upon your vehicle's modifications and tuning/calibration. The horsepower numbers represented above are calculated based strictly on choke flow of the compressor map (total turbo capability), which represents the potential flywheel horsepower.

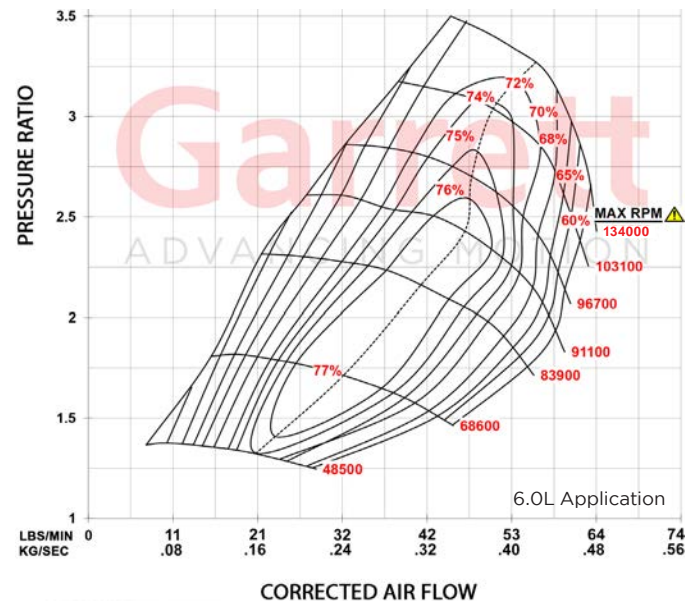
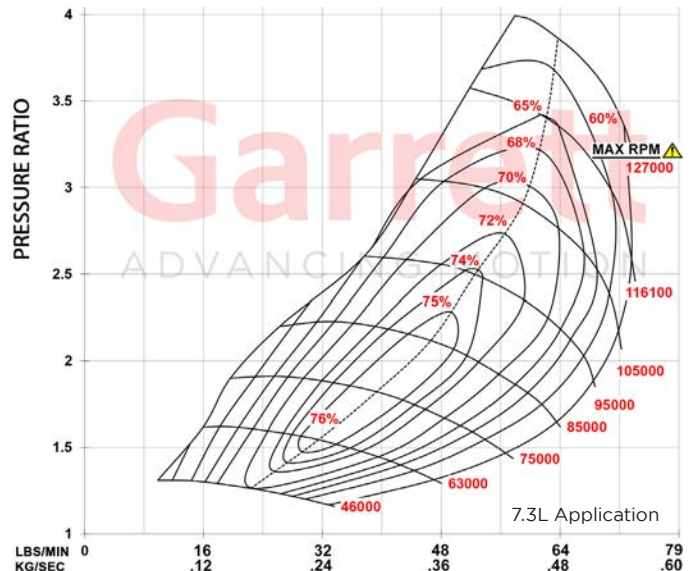



POWERMAX™ DIRECT FIT PERFORMANCE INTERCOOLER

Application: 2015+ Ford Mustang 2.3L EcoBoost
Supports Up To 600 Horsepower | C.A.R.B Certified ✓
Part Number: 857564-6001

The Garrett Direct Fit Performance Intercooler is C.A.R.B. certified (EO# D-794) and fits the 2015+ 2.3L EcoBoost Mustang in the stock location and can support up to 600 horsepower. The aluminum core features advanced offset fin design and vacuum brazed bar-and-plate construction resulting in superior thermal and fatigue performance. CFD optimized cast aluminum end tanks reduces recirculation and maximizes flow. The complete assembly results in up to a 30% reduction in pressure drop and up to a 40 °F reduction in charge air temperature.

This direct fit performance intercooler installs in 2.5 hours and reuses the stock bolts, hoses, and clamps. Removal of the OE grill shutters required. For more information including Installation instructions please visit our website: www.garrettmotion.com/racing-and-performance/performance-catalog/intercoolers/

Features:

- Supports up to 600 horsepower
- C.A.R.B Certified (EO# D-794)
- 60% larger core than stock
- Installs in stock location
- Up to a 40 °F reduction in temperatures

Part Number		857564-6001
Vehicle	Make	Ford
	Model	Mustang
	Year	2015+
Engine	Type	2.3L
	Fuel	Gas
Weight	16.5 LBS	
Size Specs	21" x 5.32" x 5.4"	





POWERMAX™ DIRECT FIT PERFORMANCE INTERCOOLER

Application: 2015+ Subaru WRX 2.0L

Supports Up To 530 Horsepower

Part Number: 891185-6001

The direct fit Subaru WRX performance charge air cooler boasts a 70% larger core that helps reduce intake manifold temperatures up to 30 °F (16.7 °C). Optimized end tanks improve air flow through the core. This performance intercooler showed an increase of up to 16 HP (12 kW) and 15 lb-ft (20 N-m) of torque compared to OE during back to back dyno comparisons in a wind tunnel which generates air velocity that matches vehicle speed. During testing the heat saturation point increased from 4 dyno pulls to 6 dyno pulls.

This direct fit performance intercooler installs in 2.5 hours and reuses the stock bolts, hoses, and clamps. Removal of the OE grill shutters required. For more information including Installation instructions please visit our website: www.garrettmotion.com/racing-and-performance/performance-catalog/intercoolers/

Features:

- Supports up to 530 HP (395 kW)
- 70% larger core than stock
- Installs in stock location
- Up to 16 HP (12kW) and 15 lb-ft (20 Nm) of torque
- Average 30° F (16.7° C) reduction in intake temp
- Cast aluminum end tanks
- Advanced offset fin design
- Bar-and-plate construction

Part Number		891185-6001
Vehicle	Make	Subaru
	Model	WRX
	Year	2015 +
Engine	Type	2.0L FA20F
	Fuel	Gas
Size Specs	13" x 4" x 10.2"	
	330mm x 102mm x 259mm	

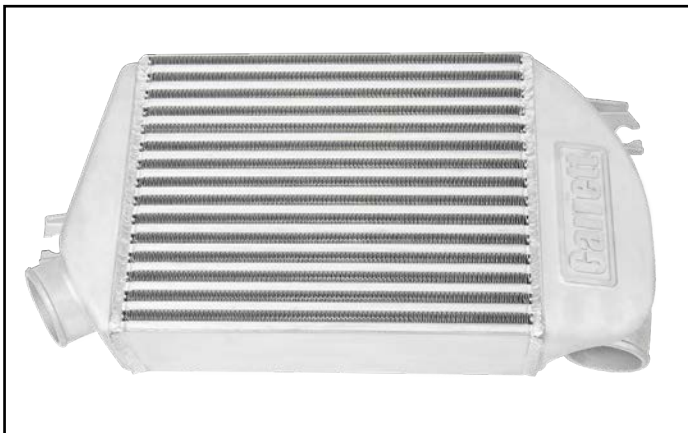



POWERMAX™ DIRECT FIT PERFORMANCE INTERCOOLER

Application: 2015+ BMW M3 | M4

Supports Up To 980 Horsepower

Part Number: 888883-6001 Raw Finish | 888883-6002 Black Finish

Garrett Powermax™ direct fit performance charge air cooler for the 2015+ BMW M3 and M4 boasts a 47% larger core with dual pass coolant flow to help reduce intake manifold temperatures by an average of 10 °F. CFD optimized end tanks improve airflow through the core. An average increase of 12.4 horsepower and 4.9 lb-ft of torque were measured during back to back dyno pulls. This direct-fit performance intercooler installs in 1.5 hours and reuses the stock bolts, hoses, and clamps.

Features:

- Supports up to 980 HP (730 kW)
- 47% larger core than stock
- Installs in stock location
- Up to 12.4 HP (9kW) and 4.9 lb-ft (6.7 Nm) of torque
- Cast aluminum end tanks
- Air-to-liquid design
- Bar-and-plate construction

Part Number	Raw Finish	888883-6001
	Black Finish	888883-6002
Vehicle	Make	BMW
	Model	M3 M4
	Year	2015+
Engine	Type	I6
	Fuel	Gas
Weight	14.1 lbs / 6.4 kg	
Size Specs	7.2" x 9.8" x 3.6"	
	183mm x 249mm x 92mm	





POWERMAX™ DIRECT FIT PERFORMANCE INTERCOOLER

Application: 2016+ Honda Civic 1.5T SI

Supports Up To 660 Horsepower

Part Number: 893516-6001

Garrett Powermax™ direct fit performance charge air cooler for the 2016+ Honda Civic 1.5T SI has a 90% larger core than stock and helps reduce intake manifold temperatures up to 60 °F (15.6 °C) at heat soak. CFD optimized end tanks improve air flow distribution through the core. This performance intercooler showed a max increase of up to 17 WHP (12.7 kW) and 14 lb-ft of torque (19 N-m) compared to OE during back to back dyno comparisons in a wind tunnel which generates air velocity that matches vehicle speed.

This direct fit performance intercooler installs in 3 hours and reuses the stock bolts, hoses, and clamps. Some modification to the shroud required. For more information including Installation instructions please visit www.garrettmotion.com/racing-and-performance/performance-catalog/intercoolers/

Features:

- Supports up to 660 HP (492 kW)
- 90% larger core than stock
- Installs in stock location
- Max increase of 17 HP (12.7 kW) and 14lb-ft (19 N-m)
- Up to 60 °F (15.6 °C) reduction in intake temp
- Cast aluminum end tanks
- Advanced offset fin design
- Bar-and-plate construction

Part Number		893516-6001
Vehicle	Make	Honda
	Model	Civic
	Year	2016+
Engine	Type	1.5L/SI
	Fuel	Gas
Weight	12.56 kg	
Size Specs	27.5" x 3.5" x 6.2"	
	698.5mm x 88.9mm x 157.5mm	





Garrett
ADVANCING MOTION

INTERCOOLER CORES

CHARGE AIR COOLERS

Utilizing advanced thermal technology, Garrett intercoolers offer superior fatigue protection for the high boost pressures and temperatures of today's extreme engines. With over 75 years of charge air cooler experience, Garrett remains ahead of the industry in intercooler design and function making it the number one choice for some of the premier names in the performance car industry - Roush, Saleen, Mercedes-Benz AMG, Ford SVT, GM, and McLaren have all turned to Garrett to cool their hottest models.

We now offer this expertise and quality to enthusiasts, in a full range of intercooler cores that are manufactured in-house by Garrett technicians. The bar and plate construction offers hi-performance, in a compact design using high strength vacuum brazed aluminum alloys with advanced fin designs to ensure greater heat transfer effectiveness and durability. From air-to-air cores sized for sport compact cars to air-to-liquid cores capable of supporting 1000+ hp, we can provide optimum performance for nearly any application.

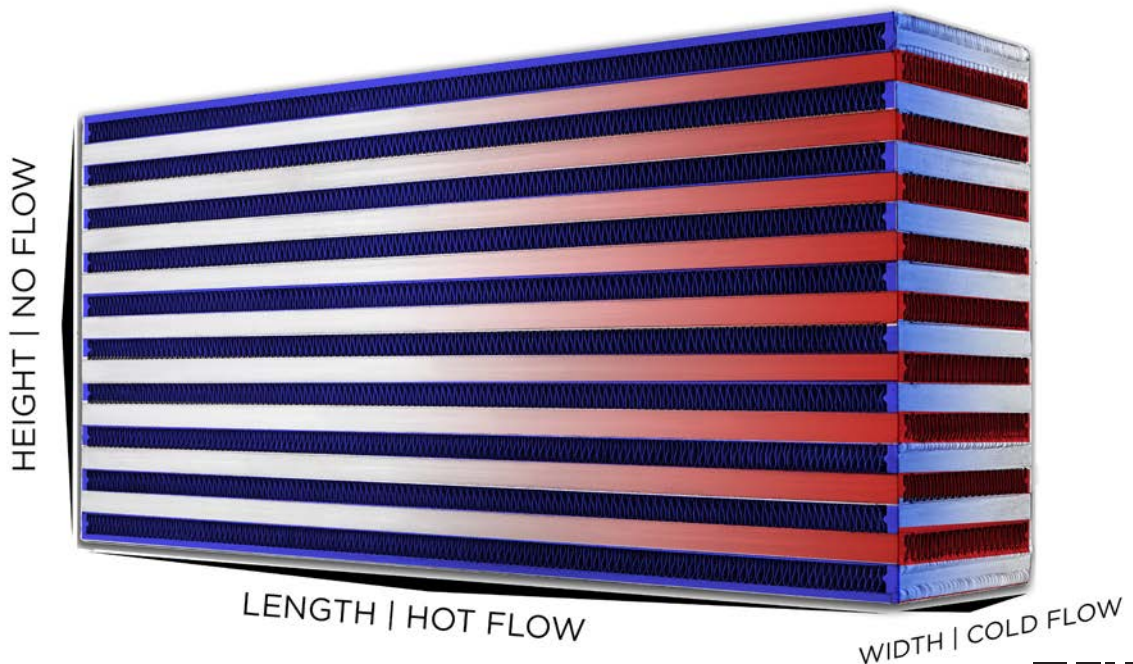



Part Number	Model	Supported Horsepower	Length Hot Flow		Height No Flow		Width Cold Flow	
			(in)	(mm)	(in)	(mm)	(in)	(mm)
* 848054-6012	Air / Air	300	10.2	260	8.1	205	4.7	120
703518-6015	Air / Air	310	18.0	457	6.4	163	3.0	76
703521-6003	Air / Air	375	10.0	254	12.3	312	4.5	114
703518-6016	Air / Air	410	18.0	457	8.0	203	3.0	76
703520-6025	Air / Air	425	18.0	457	8.0	203	3.5	89
* 848054-6013	Air / Air	450	13.5	343	8.6	219	5.5	140
703518-6018	Air / Air	475	24.0	610	6.4	163	3.0	76
703520-6009	Air / Air	500	24.0	610	6.4	163	3.5	89
703518-6017	Air / Air	510	18.0	457	10.5	267	3.0	76
703520-6002	Air / Air	550	14.0	356	12.1	307	3.5	89
848054-6004	Air / Air	600	21.0	533	5.4	137	5.3	135
848054-6024	Air / Air	600	13.0	330	10.2	259	4.0	102
487085-6002	Air / Air	600	20.1	511	11.2	284	3.0	76
703520-6010	Air / Air	600	24.0	610	8.0	203	3.5	89
893513-6001	Air / Air	660	27.5	699	6.2	157	3.5	89
* 848054-6037	Air / Air Vertical Flow	750	8.0	203	24.0	609	3.5	89
* 858893-6001	Air / Air	750	9.0	229	22.1	560	4.0	102
848054-6015	Air / Air	750	21.0	533	9.4	239	5.3	135
703518-6004	Air / Air	750	18.0	457	12.1	307	3.0	76
703522-6008	Air / Air	750	18.0	457	11.2	284	4.5	114
703522-6004	Air / Air	785	18.0	457	12.1	307	4.5	114
848054-6020	Air / Air	800	26.3	668	7.8	198	4.3	109
703520-6011	Air / Air	800	24.0	610	10.5	267	3.5	89
848054-6005	Air / Air	800	13.1	333	8.6	218	5.0	127
848054-6001	Air / Air	870	20.0	508	12.5	318	3.5	89
703518-6005	Air / Air	900	24.0	610	12.1	307	3.0	76
703520-6005	Air / Air	925	24.0	610	12.1	307	3.5	89
848054-6021	Air / Air	950	26.8	681	10.4	264	4.0	102
703522-6005	Air / Air	950	24.0	610	12.1	307	4.5	114
486827-6002	Air / Air	1000	23.7	602	12.0	305	3.8	97
* 848054-6039	Air / Air Vertical Flow	1100	12.0	305	22.4	568	4.5	114
848054-6003	Air / Air	1140	22.0	559	14.0	356	4.5	114
701596-6001	Air / Air	1260	27.8	706	12.7	323	5.1	130
* 858893-6003	Air / Air	1275	14.0	356	22.1	561	4.5	114

* New Cores

Part Number	Model	Supported Horsepower	Length Hot Flow		Height No Flow		Width Cold Flow	
			(in)	(mm)	(in)	(mm)	(in)	(mm)
717874-6009	Air / Liquid	500	3.8	97	3.8	97	9.8	249
717874-6008	Air / Liquid	750	3.8	97	3.8	97	11.7	297
873213-6002	Air / Liquid	980	7.2	183	3.6	91	9.8	249
734408-6005	Air / Liquid	1000	4.8	122	4.5	114	11.9	302

Garrett ancillary components are factory replacement parts for most G-Series and GTX Gen II turbochargers. From bolts, to clamps, actuator brackets, rod ends, o-rings and more. G-Series turbochargers have many new features on the compressor and CHRA sides of the turbo. The new speed sensor plug, bolt, and o-ring, pressure port plug, and oil and water fittings to name a few. These small ancillary components are now available for purchase.

Part Number	Description	Model
400809-0203	Pressure Plug Comp Hsg	G-Series GTX42 45 47 50 55 Gen II
403069-0242	O-Ring Speed Sensor	G-Series GTX47 50 55 Gen II
871104-0001	Plug Speed Sensor	
400674-0516	Bolt Speed Sensor	
400975-0203	Bolt Compressor Hsg	G25 G30 G35-900
400975-0303	Bolt Compressor Hsg	G35-1050 GTX28 Gen II
871795-0001	Clamp Compressor Hsg	G25 G30 G35-900
871795-0003	Clamp Compressor Hsg	G35-1050
403069-0077	O-Ring Compressor Hsg	GTX30 35 Gen II
403069-0157	O-Ring Compressor Hsg	G25 G30-660
403069-0162	O-Ring Compressor Hsg	G30-770 G30-900 G35
403069-0164	O-Ring Backplate	GTX28 30 35 Gen II
767567-0002	Fitting Oil Inlet	G25 30 35 GTX28 30 35 Gen II
434705-00041	Plug Water	
872902-0001	Fitting Water	
444657-0006	Washer Copper	
400702-1025	Circlip Rod End	
413885-0032	Rod End	
400146-0207	Nut Actuator Bracket / Rod End	
876079-0001	Bracket Actuator Standard Rotation	G25
876079-0002	Bracket Actuator Reverse Rotation	G25
876079-0003	Bracket Actuator Twin Scroll	G25 G30-660
826466-0001	V-Band Turbine Inlet	G25 30 35 GTX30 35 Gen II GTX28 (Turbine Outlet)
446397-0364	V-Band Turbine Outlet	G25 30 35 GTX30 35 Gen II
446397-0382	V-Band Center Hsg - Turbine Hsg	G25 30 35
400515-0212	Locknut V-Band	G-Series GTX Gen II



BOLTED INLET TURBINE HOUSINGS: T25 | T3 | T4 | T6 | GBC14

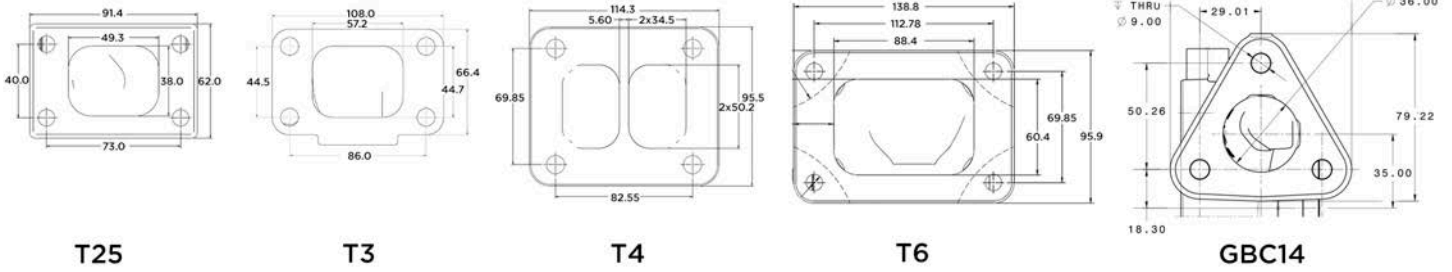

V-BAND INLET TURBINE HOUSINGS:

Diagram	V-Band Turbine Inlet Flange Reference		
1	GT28	GTX28	GTX28 Gen II
2	G25	G30	G35
2	GT30	GTX30	GTX30 Gen II
2	GT35	GTX35	GTX35 Gen II
3	G42	G45	G40
4	G57 G55	GTX55	GTX55 Gen II

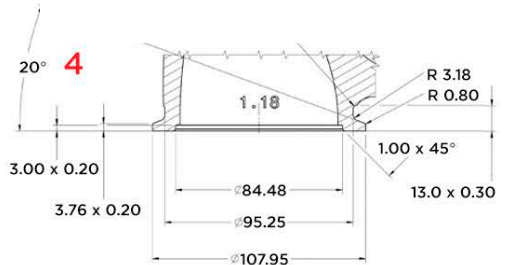
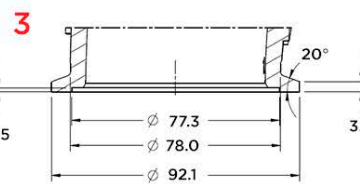
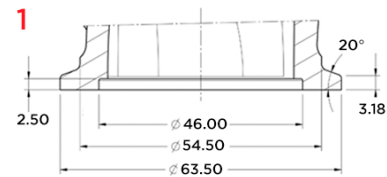

TURBINE HOUSING OUTLET (DOWN PIPE) FLANGE

Garrett Series	Turbine Housing Inlet Type						
	All	V-Band	T25	T3	T3 WG	T4	T6
G25 G30 G35	5						
G40 G42 G45		6				19	
G47 G50	8						
G55		9					8
G57	9						
GT28 GTX28 GT25		7	15				
GT28 RB Style			16				
GBC14			15				
GBC17 20 22	18						
GBC35 GBC37	5						
GT30 GTX30		5		17	14		
GT35 GTX35		5		17	14	20	
GTX40	11						
GTX42 GTX45	12						
GTX47 GTX50	8						8
GTX55		9					8
GTX36 GTW38	13						
GT2052	10						
GT2252	21						

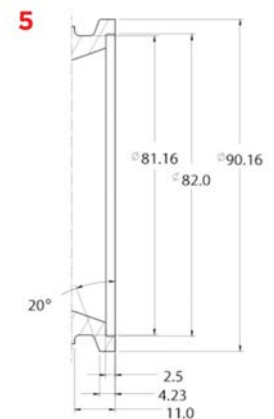

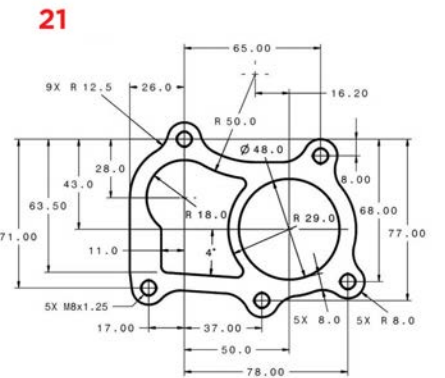
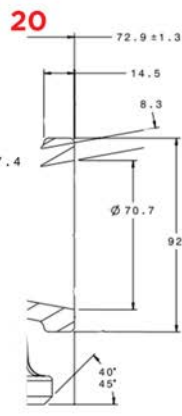
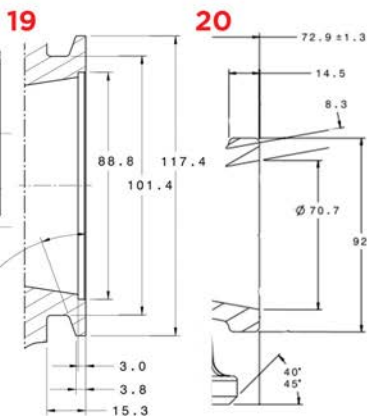
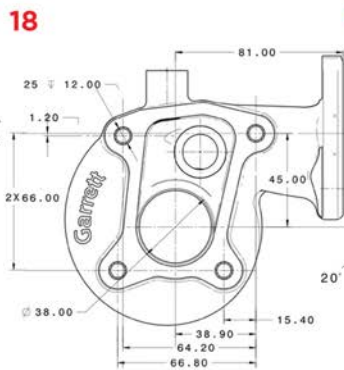
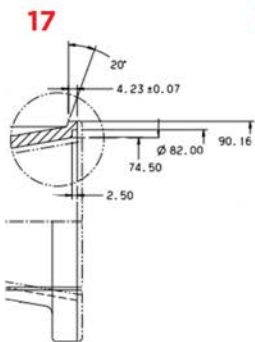
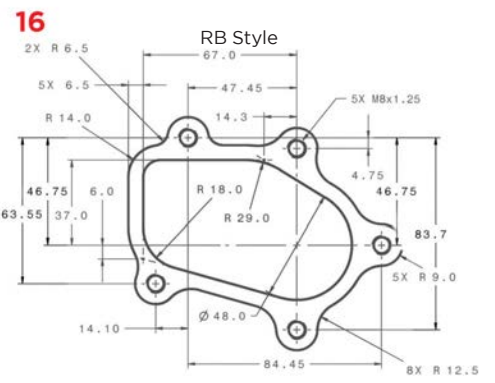
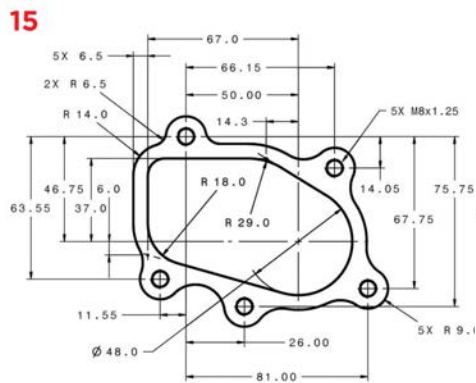
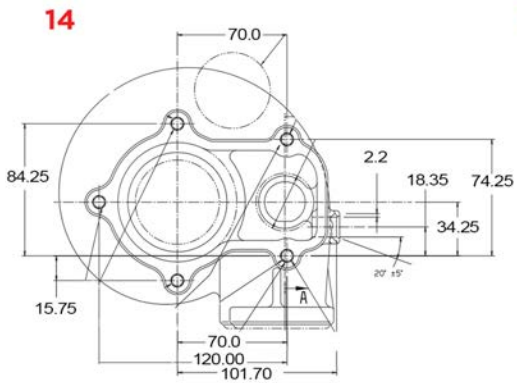
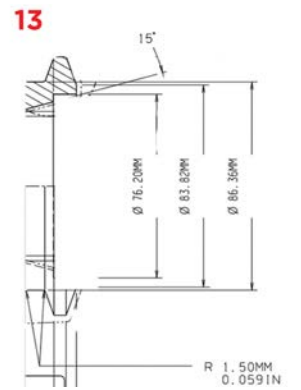
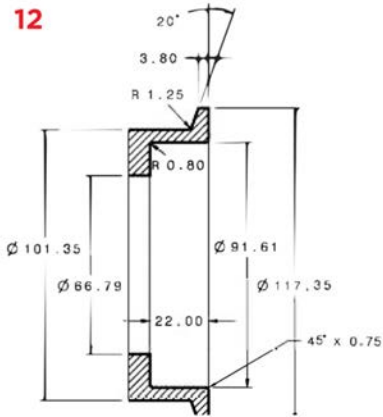
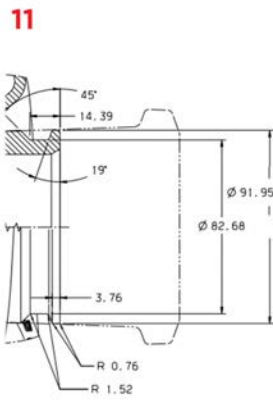
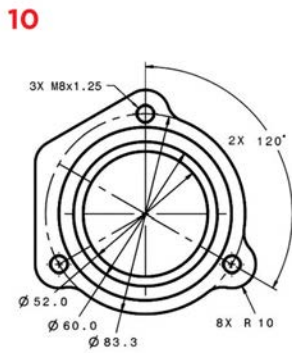
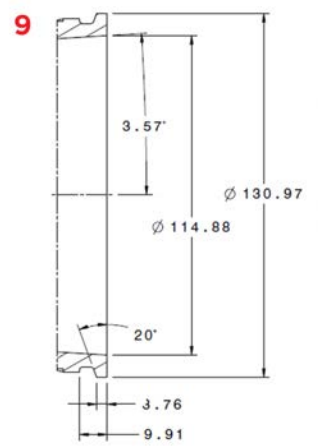
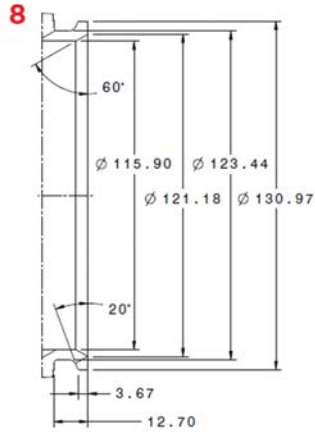
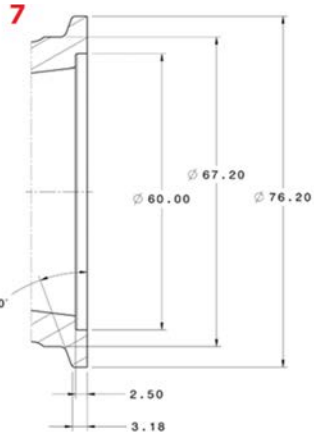
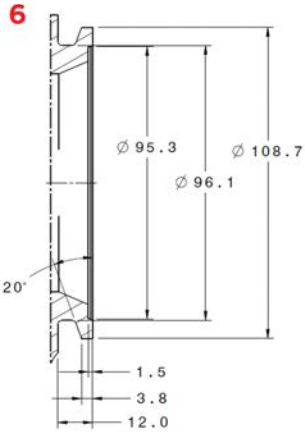

POSSIBLE CAUSES	SYMPTOMS								SOLUTION			
	Engine lacks power	Black smoke	Excessive oil consumption	Blue smoke	Noise	Excessive oil - compressor end	Excessive oil - turbine end	Drag or bind in rotating assembly		Excessive rotating assembly play	Damaged compressor wheel	Damaged turbine wheel
Dirty air cleaner element	●	●										Clean or replace filter element
Plugged crankcase breathers			●									Clear obstruction per manufacturer's manual
Air cleaner element missing, leaking, or loose connections to turbo								●			●	Replace, repair or reconnect air cleaner element per manufacturer's manual
Collapsed or restricted air pipe before turbocharger	●	●										Inspect pipe for damage or obstruction, replace or repair
Restricted or damaged crossover pipe - turbo to inlet manifold	●	●										Inspect pipe for damage or obstruction, replace or repair
Foreign object between cleaner and turbocharger	●	●						●	●	●		Inspect air intake piping, remove foreign object
Foreign object in exhaust system (check engine)	●	●						●	●	●	●	Inspect exhaust piping only when engine is not running and cold, remove foreign object
Turbocharger flanges, clamp or bolts loose	●	●	●	●	●	●	●	●	●	●	●	Inspect all connecting hardware for damage, ensure tight fits per installation instructions
Inlet manifold cracked, gaskets, loose or missing, connections loose	●	●	●	●	●							Remove and inspect inlet manifold for damage to castings and gaskets, replace if needed
Exhaust manifold cracked, burned, gasket loose, blown or missing	●	●										Remove exhaust manifold only when engine is cold and not running and inspect for damage to castings and gaskets, replace if needed
Restricted exhaust system					●							Inspect exhaust system only when engine is cold, not running, remove obstruction
Oil lag at start-up								●	●			Inspect lubrication system lines, filters and oil for obstruction, remove obstruction
Insufficient lubrication								●	●			Inspect lubrication system lines, filters and oil for obstruction, remove obstruction
Lubricating oil contaminated with dirt or other material								●	●			Replace all filters and lubricating oil with new per manufacturer's manual
Improper lubricating oil type used								●	●			Replace lubricating oil with correct grade
Restricted oil feed line							●	●	●			Remove and inspect oil line, remove obstruction
Restricted oil drain line								●				Remove and inspect oil line, remove obstruction
Turbine housing damaged or restricted	●	●			●						●	Remove turbine housing, inspect for cracks or wear, replace if needed
Turbocharger seal leakage			●	●		●	●					Inspect for proper oil feed / drain line installation. Contact Garrett distributor for rebuild
Worn journal bearings	●	●	●			●	●	●	●	●	●	Contact a Garrett performance distributor or Garrett master distributor
Excessive dirt build-up behind turbine wheel	●	●	●	●	●			●	●	●	●	Inspect air cleaner element and intake piping for damage or leaks, replace if needed. Clean compressor wheel and housing
Excessive carbon build-up behind compressor housing	●	●	●	●	●			●	●	●	●	Inspect crankcase ventilation
Too fast acceleration at initial start									●	●		Decrease acceleration at initial start
Too little warm-up time									●	●		Extend warm-up period
Fuel pump malfunction	●	●										Refer to engine manufacturer's manual and replace if needed
Worn or damaged injectors	●	●										Inspect injectors for damage and replace if needed
Valve timing	●	●										Refer to engine manufacturer's manual and replace if needed
Burned valves	●	●										Refer to engine manufacturer's manual and replace if needed
Worn piston rings	●	●										Refer to engine manufacturer's manual and replace if needed
Burned pistons								●	●			Refer to engine manufacturer's manual and replace if needed
Leaking oil feed line								●				Remove and inspect oil line, remove obstruction
Excessive engine pre-oil			●	●		●	●					Refer to engine manufacturer's manual and replace if needed
Excessive engine idle			●	●			●	●			●	Refer to engine manufacturer's manual and replace if needed
Coked or sludged center housing									●			Contact a Garrett performance distributor or Garrett master distributor
Oil pump malfunction			●	●		●	●	●	●	●	●	Refer to engine manufacturer's manual and replace if needed
Oil filter plugged	●	●	●	●	●							Refer to engine manufacturer's manual and replace if needed
Oil bath cleaner: air inlet screen restricted / dirty air cleaner	●	●	●	●	●							Replace air inlet screen
Oil bath air cleaner: oil pull-over / oil viscosity too low or high	●	●	●	●	●							Replace lubricating oil with correct grade
Boost control malfunction: wastegate	●	●	●	●	●	●	●	●	●	●	●	Inspect for damage, leaks or obstructions; replace or repair if needed
Boost control malfunction: vnt	●	●	●	●	●	●	●	●	●	●	●	Contact a Garrett performance distributor or Garrett master distributor
Boost control malfunction: engine management system	●	●	●	●	●	●	●	●	●	●	●	Refer to manufacturer's manual and adjust as needed

● Probable cause
□ Not a probable cause

Nearly all turbocharger-related problems are the result of a handful of causes. Knowing how to recognize the symptoms of these issues early and link them with causes will help you save downtime and money. The chart above outlines the probable causes and noticeable conditions of the most common turbocharger maladies as well as what you can do to solve them. If a problem falls outside of your mechanical comfort level, contact a Performance Distributor or a Master Distributor for assistance.

www.GarrettMotion.com/Racing-and-Performance/Distributor-Locator/

Terms and Conditions

Garrett, the Garrett Advancing Motion logo, and all product names appearing on our websites are among the trademarks and/or service marks owned by Garrett Transportation I Inc., a subsidiary of Garrett Motion Inc. (collectively referred to herein as “Garrett”). No trademark or service mark or other license is granted in connection with the materials contained on any of Garrett’s websites.

Nothing contained herein shall be construed as conferring by implication, estoppel or otherwise a license to any patent, trademark or other intellectual property of Garrett or any third party. Garrett makes no representations or warranties that use of the information contained on this website will not infringe any patent, trademark or other intellectual property right of Garrett or any third party. Should you view Garrett’s website and respond with information (excluding personal information, which is addressed under the Internet Privacy Policy) including questions, comments or suggestions, such information shall be deemed to be non-confidential and Garrett shall have no obligation with respect to such information and shall be free to reproduce, use, disclose and distribute the information without limitation. Garrett shall be free to use any ideas, concepts, know-how or techniques contained in such information for any purpose including but not limited to developing, manufacturing and marketing products incorporating such information.

Under no circumstances will Garrett be liable to any person or entity for direct, indirect, special, incidental, consequential or other damages based on use of this website or any other website to which this website is linked, including, without limitation, lost profits, business interruption, or loss of programs or information, even if Garrett has been specifically advised of the possibility of such damages.

Consumers are required to work through an authorized Garrett distributor to process warranty claims. When Garrett requires the examination of a failed part, Garrett will promptly notify Customer and will await receipt of the failed part before processing the claim. If Garrett ultimately determines that the failed part is covered under the Limited Warranty, Garrett will reimburse Customer for the actual cost of ground shipment for any part found to be defective.

No representative or distributor of Garrett has authority to alter this warranty. This warranty may only be modified by an agreement signed by an authorized officer of a Garrett legal entity.

We recommend that Garrett products be installed by qualified automotive technicians. If you have doubts as to your ability to install our product, consult with a local automotive repair company. Carefully read all attached instructions prior to starting installation. If you have questions about the enclosed parts or instructions, call the distributor that you purchased the kit from for clarification. Prior to product installation, ensure that the vehicle is parked on a level surface and the engine is cool. Engine fluids and components can be extremely hot following normal vehicle operation. Avoid direct contact of engine fluids or components.



BOOST ADVISER

TURBO MATCHING MADE EASY
MOBILE AND DESKTOP DEVICES

1. ENTER YOUR PARAMETERS
2. BROWSE TURBO MATCHES
3. LOCATE A DISTRIBUTOR

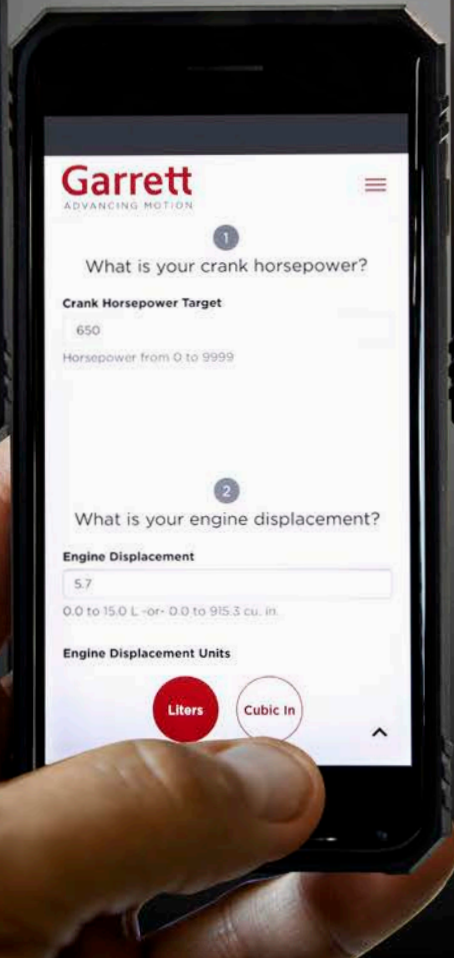
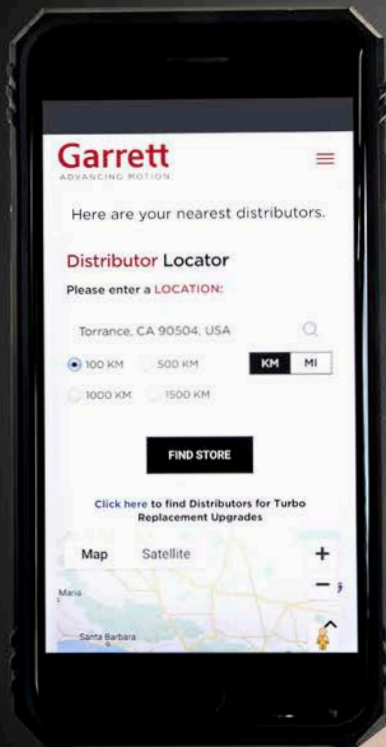

Garrett
ADVANCING MOTION

Garrett

ADVANCING MOTION



Turbochargers | Intercoolers | Valves | Accessories

PERFORMANCE CATALOGUE VOL 9

TABLE OF CONTENTS

- 04** WHY CHOOSE GARRETT
 - 07** HOW TO READ A COMPRESSOR MAP
 - 12** G-SERIES II
 - 20** G-SERIES
 - 46** G-XRACE
 - 54** GTX GEN II
 - 74** GARRETT BOOST | CLUB LINE
 - 82** GTW SERIES
 - 88** GT SERIES
 - 100** CLASSIC SERIES
 - 104** GARRETT VENT | WASTEGATES
 - 108** GARRETT VENT | BLOW-OFF VALVES
 - 110** ACCESSORIES | SPEED SENSORS | BOOST GAUGES | ACTUATORS
 - 112** G-SMART BLUETOOTH MODULE
 - 114** POWERMAX | VEHICLE SPECIFIC TURBOCHARGERS & INTERCOOLERS
 - 139** PERFORMANCE INTERCOOLER CORES
 - 141** ANCILLARY COMPONENTS
 - 142** TURBINE FLANGE DIAGRAMS
 - 144** TROUBLESHOOTING GUIDE
-

OUR HISTORY

The heritage of our turbo business began in 1936 when young Cliff Garrett formed his company in a tiny, one-room office in Los Angeles. Cliff founded the company that would later become the Garrett Corporation. Number of employees, 1. Number of customers, 1. In the 1950s, it successfully added boosting a Caterpillar C9 tractor signaling the birth of automotive turbocharging.

With over sixty-five years of boosted experience, Garrett technology has been utilized by nearly every major global auto maker, resulting in approximately 100 million vehicles with our products and an average launch rate of 100 new applications annually spanning from gas, to diesel, fuel cell, and racing and performance applications.

From the world's first turbocharged production car – the Oldsmobile Jetfire Rocket - to the first Garrett turbocharged car to win the Indianapolis 500, Garrett's industry-leading technology and patented designs are used daily for both OE and aftermarket vehicle applications.

Today, our Garrett legacy in the automotive industry helps create some of the most innovative and high-performing turbochargers in the world that can enable a four cylinder turbocharged engine to perform like a non-turbocharged V6 engine while providing 20-40% greater fuel efficiency. Garrett's global engineering network continues to inspire technological innovation around the world.

The products contained in this catalog are performance aftermarket parts that are not legal for street use in certain states or countries, unless a type-approval/executive order has been obtained e.g. by the distributor of the product. Check with your distributor before using in any vehicle on a public road or highway. You should check with your state or applicable country authorities to find out whether these products are legal for street use in your state or country. Applicable laws may also prohibit tampering with parts or vehicle design elements affecting emissions on vehicles intended for use on public roads. You are responsible for ensuring that the use of this product complies with all applicable laws, regulations and ordinances (including, but not limited to, emission, noise, safety, and type-approval/executive order). Any vehicle modifications using the products in this catalog are completed AT YOUR OWN RESPONSIBILITY and AT YOUR OWN RISK. A vehicle modification using these performance aftermarket products may affect or void a vehicle's warranty, operating license/registration or type-approval/executive order. You should consult your local laws, as well as the owner's manual and service manual of your vehicle. You should also contact your vehicle's manufacturer to determine what effect modifications may have on safety, warranty, performance, and other aspects of your vehicle. These products generally may be used on racing vehicles that will never be driven on public roads or highways.

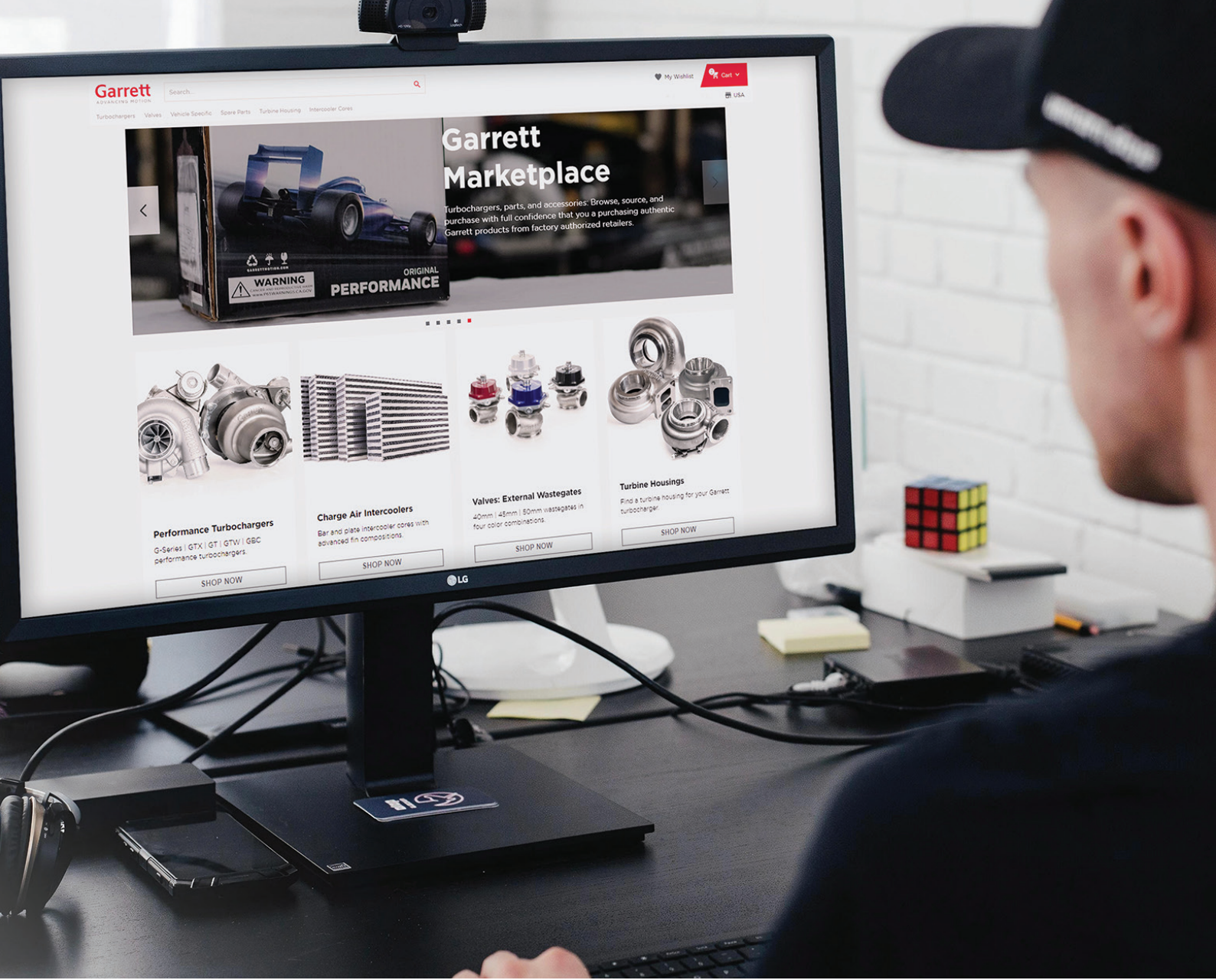

SHOP.GARRETTMOTION.COM

GARRETT **MARKETPLACE**

Browse, Source, Purchase
Genuine Garrett Products
From Authorized Distributors



SHOP NOW

074,75

your own kit

Housing: None

GT35 GTX35 GTX35 Gen II
Turbine Housing Standard
Rotation 1.06A/R T3 Inlet V-Band
Outlet

IN STOCK

[View more](#)

GTX35 Gen II Supercore Standard Rotation 66MM Comp Ind

Reference: 851154-5004S



Starting at: **\$1,074.75**
* Excluding taxes

IN STOCK

Create your own kit

Turbine Housing: None

GT35 GTX35 GTX35 Gen II
Turbine Housing Standard
Rotation 1.06A/R T3 Inlet V-Band
Outlet

IN STOCK

[View more](#)

Garrett
ADVANCING MOTION



Garrett Marketplace

Turbochargers, parts, and accessories: Browse, source, and purchase with full confidence that you a purchasing authentic Garrett products from factory authorized retailers.



Garrett
ADVANCING MOTION

Garrett Vent | Ext
Wastegate GVW
50mm

VIEW MORE

Garrett
Waste
45mm

VIEW M

Garrett
ADVANCING MOTION



Garrett
ADVANCING MOTION

WHY CHOOSE GARRETT TURBOCHARGERS

A turbo is a high technology product that requires superior design and intensive capital to produce. It must meet severe requirements that only a world class manufacturer can achieve.

Garrett is one of the few turbocharger manufacturers that subjects our turbos to several OE qualification tests. These tests ensure Garrett produces a safe and reliable turbo for OE applications. When you buy a Garrett turbocharger you can be sure it is reliable.

On-Engine Durability - More than 1,000-hours of general turbocharger durability, is run on-engine in one of Garrett's engineering laboratories.

Gas Stand Cyclic Durability - A several hundred hour durability test is conducted on a gas stand where the turbo is run past its normal operating limits.

Compressor & Turbine Housing Containment - A compressor/turbine wheel is weakened to hub burst at a specific speed. No portion of the wheel is allowed to penetrate a containment shroud surrounding the turbocharger. A test to ensure safety. See full article at www.GarrettMotion.com

Shaft Motion - The maximum tolerances of the bearing system are tested for rotordynamic stability beyond the maximum turbocharger operating speed. This means no bearing problems and a long turbo life.

Thrust Bearing Capacity - A test that stresses the thrust bearing at extreme conditions. This test makes sure your Garrett turbocharger can tolerate the load you put it through.

Compressor & Turbine Seal - Multiple turbochargers are run on-engine under conditions designed to cause seal leakage. No significant leakage is allowed during these tests.

Heat Soak Back - A turbocharger instrumented with thermocouples is taken beyond maximum operating temperature and shut down hard! Repeat the test four more times and make sure maximum temperatures stay within our strict limits to avoid oil coking or build up inside the center housing. This is particularly critical for high temperature gasoline applications.

Compressor & Turbine Performance - The entire operating range of both the compressor and turbine are mapped on one of Garrett's performance gas stands. These test cells are calibrated to strict standards to assure accuracy and consistency.

Compressor & Turbine Blade Frequencies - Garrett has strict requirements for compressor and turbine blade natural frequency. This is critical on large trims where the blade must be stiff enough to withstand potentially damaging vibrations.

Thermal Cycle - A several hundred hour endurance test that cycles the turbocharger from low temperature to glowing red every 10 minutes. To ensure a long turbo life, no cracking of the turbine housing or distortion of the heat shroud are allowed.

Rotor Inertia - A measurement made to document the rotational inertia of Garrett's compressor and turbine wheels. Garrett's turbochargers are known for their high flow / low inertia characteristics.

Shaft Critical Speed - An analytical test that ensures that destructive shaft critical speeds are well out of the turbocharger operating range. For example, large wheels may require a large shaft diameter to avoid the shaft bending critical speed.

Wheel Fatigue - Garrett will only sell compressor or turbine wheels that have passed a cyclic fatigue test. Garrett runs tests on a regular basis to ensure quality and to constantly improve our products.

Turbo Vibration - The entire turbocharger is vibrated and monitored on Garrett's large shaker table to ensure product durability.

Engine power is proportional to the amount of air and fuel that can get into the cylinders. All things being equal, larger engines flow more air and as such will produce more power. If we want our small engine to perform like a large engine, or simply make our larger engine produce more power, our ultimate objective is to deliver more air into the cylinder. By installing a Garrett turbocharger, the power and performance of an engine can be dramatically increased.

HOW DOES A TURBOCHARGER DELIVER MORE AIR INTO THE ENGINE?

- (1) **Compressor Inlet:** Opening through which ambient air passes before entering the compressor.
- (2) **Compressor Discharge:** Ambient air is then compressed which raises the air's density (mass/unit volume).
- (3) **Charge Air Cooler (aka Intercooler):** cools the compressed air to increase its density and to increase resistance to detonation.
- (4) **Intake Manifold:** Directs dense air into the engine's cylinders. Each cylinder draws in an increased mass flow rate of air. Higher air mass flow rate allows a higher fuel flow rate (with similar air/fuel ratio). Combusting more fuel results in more power for a given displacement.
- (5) **Exhaust Manifold:** Directs burned fuel and exhaust gases from the cylinders towards the turbine.
- (6) **Turbine Inlet:** Directs high temperature exhaust gas towards the turbine wheel. The turbine creates back pressure on the engine which means engine exhaust pressure is higher than atmospheric pressure.
- (7) **Turbine Discharge:** A pressure and temperature drop occurs (expansion) across the turbine, which harnesses the exhaust gas' energy to provide the power necessary to drive the compressor wheel.

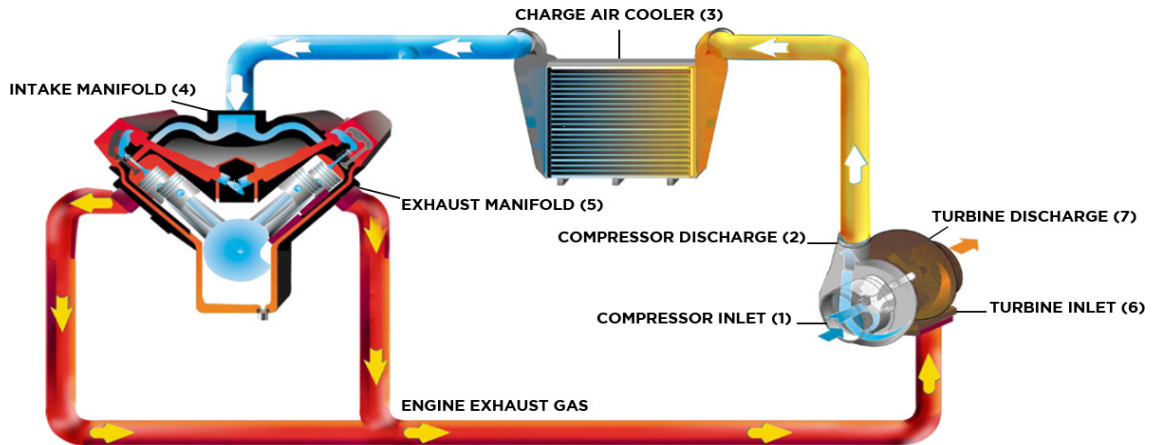

COMPONENTS OF A TURBOCHARGER

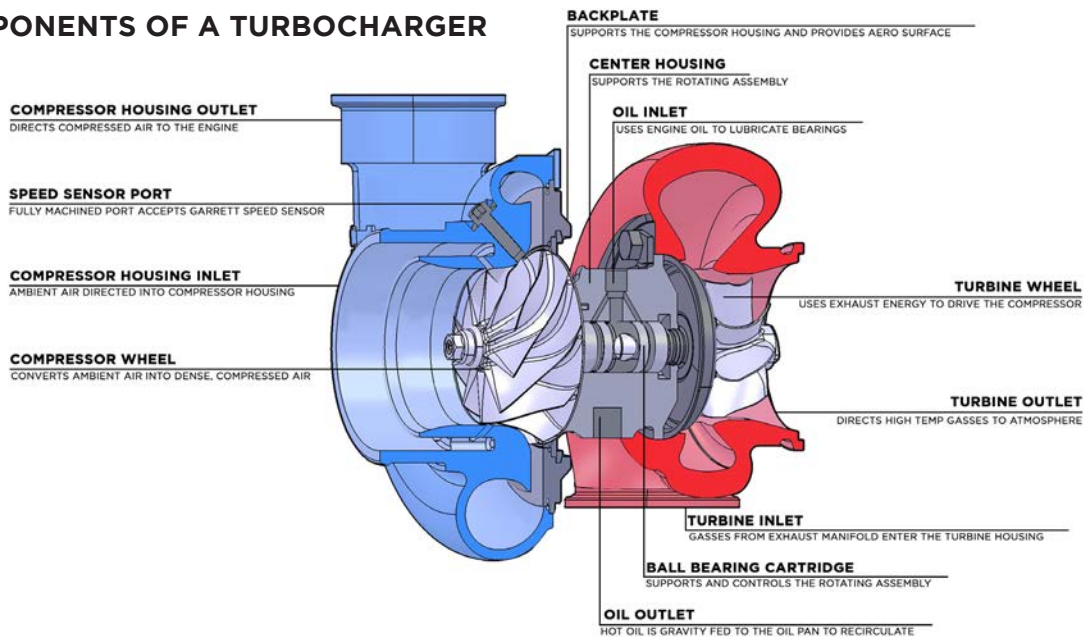

BALL BEARING TECHNOLOGY

Ball bearing innovation began as a result of work with the Garrett Motorsports group for several racing series where it received the term the “cartridge ball bearing”. The cartridge is a single sleeve system that contains a set of angular contact ball bearings on either end, whereas the traditional bearing system contains a set of journal bearings and a thrust bearing.

Turbo Response - When driving a vehicle with the cartridge ball bearing turbocharger, you will find exceptionally crisp and strong throttle response. Garrett Ball Bearing turbochargers spool up 15% faster than traditional journal bearings. This produces an improved response that can be converted to quicker 0-60 mph speed. In fact, some professional drivers of Garrett ball-bearing turbocharged engines report they feel like they are driving a large, normally aspirated engine.

Reduced Oil Flow - The ball bearing design reduces the required amount of oil required to provide adequate lubrication. This lower oil volume reduces the chance for seal leakage. Also, the ball bearing is more tolerant of marginal lube conditions, and diminishes the possibility of turbocharger failure on cold start conditions. Read more at www.GarrettMotion.com

Improved Rotordynamics and Durability - The ball bearing cartridge gives better damping and control over shaft motion, increasing reliability for both every day and extreme driving conditions. In addition, the opposed angular contact bearing cartridge eliminates the need for the thrust bearing, a common weak link in the turbo bearing system.

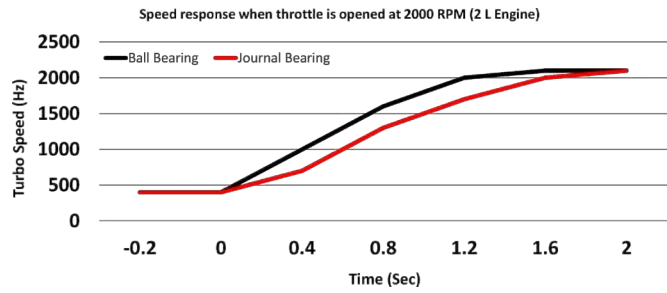

WHEEL TRIM

Trim is a common term used when talking about or describing turbochargers. For example, you may hear someone say “I have a GTXxxxx”. What is trim? Trim is a term used to express the relationship between the inducer and exducer of both turbine and compressor wheels. More accurately, it is an area ratio. Based on aerodynamics and air entry paths, the inducer for a compressor wheel is the smaller diameter. For turbine wheels, the inducer is the larger diameter.

The trim of a wheel, whether compressor or turbine, affects performance by shifting the airflow capacity. All other factors held constant, a higher trim wheel will flow more than a smaller trim wheel. However, it is important to note that very often all other factors are not held constant. So just because a wheel is a larger trim does not necessarily mean that it will flow more.

Compressor Trim = $(\text{Inducer}^2 / \text{Exducer}^2) \times 100$

Turbine Trim = $(\text{Exducer}^2 / \text{Inducer}^2) \times 100$

WHEEL MEASUREMENTS EXPLAINED

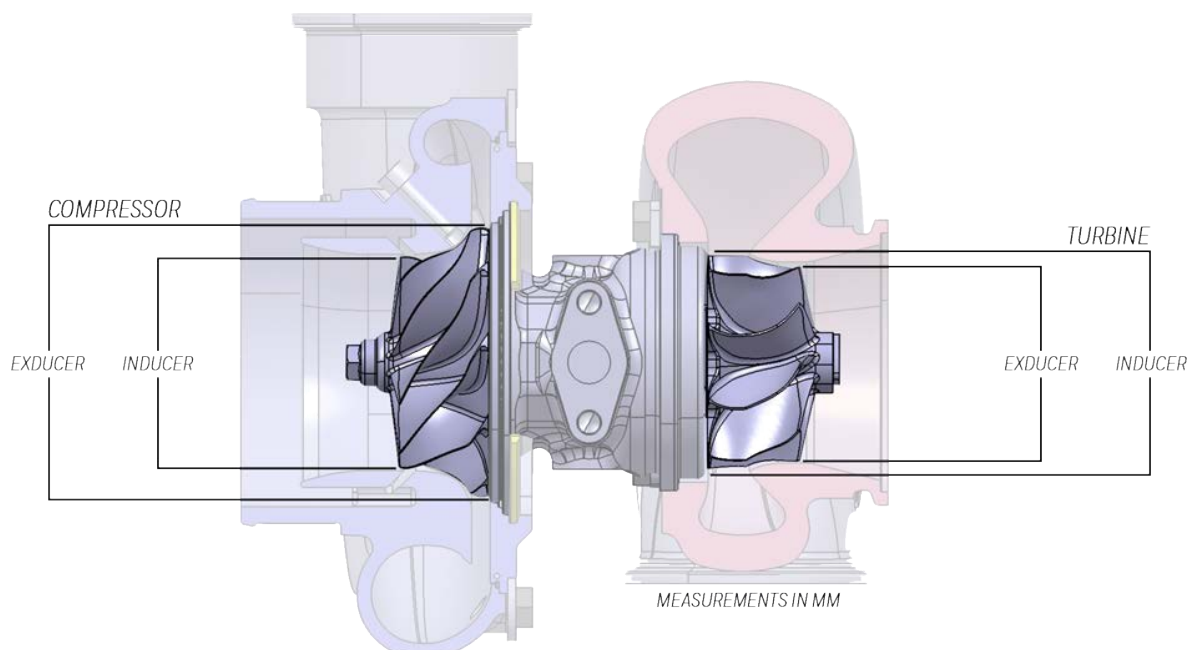

The compressor map describes each compressor's performance characteristics, including efficiency, mass flow rate, turbo speed, choke line, surge line, and pressure ratio. Below is a figure that identifies these aspects.

Efficiency Islands: Efficiency Islands are concentric regions that represent the compressor efficiency at any point on the map. The smallest island near the center of the map is the highest or peak efficiency island. As the rings move out from there, the efficiency drops by the indicated amount until the surge and choke limits are reached.

Mass Flow Rate: Mass Flow Rate is the mass of air flowing through a compressor over period of time and is expressed as lb/min. As a very general rule, turbocharged gasoline engines generate 10.0-11.0* horsepower at the flywheel for each lb/min of airflow. So, an engine with a target peak horsepower of 400 Hp will require 36-40 lb/min of airflow to achieve that target. Many people use Volumetric Flow Rate (expressed in cubic feet per minute, CFM or ft³/min) instead of mass flow rate. Volumetric flow rate can be converted to mass flow by multiplying by the air density. Air density at sea level is 0.076lb/ft³. Mass flow can be physically measured, but in many cases it is sufficient to estimate the mass flow when choosing the proper turbo.

Turbo Speed: Turbo Speed Lines are constant turbo speed measured in RPM. As turbo speed increases, the pressure ratio and mass flow increases. Turbo speed lines are very close together at the far right edge of the map indicating a potential turbo over-speed condition. Maximum turbo speed will be noted with the following symbol. **MAXIMUM TURBO SPEED** ⚠

Choke Line: The Choke Line is the right hand boundary of the compressor map and defined at the point where the efficiency drops below 58%. In addition to the rapid drop of compressor efficiency past this point, turbo speed also approaches or exceeds the recommended limit. If your actual or predicted operation is beyond this limit, a larger compressor is necessary.

Surge Line: Surge is the left hand boundary of the compressor map and represents a region of flow instability. This region is characterized by mild flutter to wildly fluctuating boost from the compressor. Continued operation within this region can lead to premature turbo failure due to heavy thrust loading. Surge will decay once the turbo speed finally slows enough to reduce the boost and move the operating point back into the stable region. This situation is commonly addressed by using a Blow-Off Valve (BOV) or bypass valve. A BOV functions to vent intake pressure to atmosphere so that the mass flow ramps down smoothly, keeping the compressor out of surge. In the case of a recirculating bypass valve, the airflow is recirculated back to the compressor inlet.

Pressure Ratio:
$$\Pi_c = \frac{P_{2c}}{P_{1c}}$$

Where:
 Π_c = Pressure Ratio
 P_{2c} = Absolute Outlet Pressure
 P_{1c} = Absolute Inlet Pressure

Absolute Pressure: It is important to use units of Absolute Pressure for both P_{2c} and P_{1c}. Absolute Pressure at sea level is 14.7 PSia. In units of PSia, the "a" refers to "absolute". This is referred to as standard atmospheric pressure at standard conditions.

Gauge Pressure: Measures the pressure above atmospheric, so a gauge pressure reading at atmospheric conditions will read zero. Boost gauges measure the manifold pressure relative to atmospheric pressure, and thus are measuring Gauge Pressure. In units of PSig, the "g" refers to "gauge". This is important when determining P_{2c}.

Calculating P_{2c}: For example, a reading of 12 PSig on a boost gauge means that the air pressure in the manifold is 12 PSI above atmospheric pressure. For standard atmospheric conditions, 12 PSig + 14.7 PSia = 26.7 PSI absolute compressor outlet pressure (P_{2c}). The pressure ratio at this condition can now be calculated: 26.7 / 14.7 = 1.82

Depression: A pressure loss upstream of the compressor caused by any restriction from the air filter or restrictive ducting. Depression can be 1 PSig or more on some intake systems. In determining pressure ratio, the absolute pressure at the compressor inlet (P_{1c}) is often LESS than the ambient pressure, especially at high load. Taking into account the 1 PSig intake depression, the pressure ratio is now: (12 PSig + 14.7 PSia) / 13.7 PSia = 1.95

Elevation: Higher elevations can have a significant effect on pressure ratio. Turbo speed increases to compensate for increases in altitude. Substitute the actual atmospheric pressure in place of the 14.7 PSI in the equations above to give a more accurate calculation. For example, at Denver's 5000 feet elevation, the atmospheric pressure is typically around 12.4 PSia. In this case, the pressure ratio calculation, taking into account the intake depression, is: (12 PSig + 12.4 PSia) / (12.4 PSia - 1 PSig) = 2.14 Compared to the 1.82 pressure ratio calculated originally, this is a big difference.

* Performance results of this product are highly dependent upon your vehicle's modifications and tuning/calibration. Horsepower numbers represented in this catalog are calculated based strictly on choke flow of the compressor map (total turbo capability), which represents the potential flywheel horsepower.

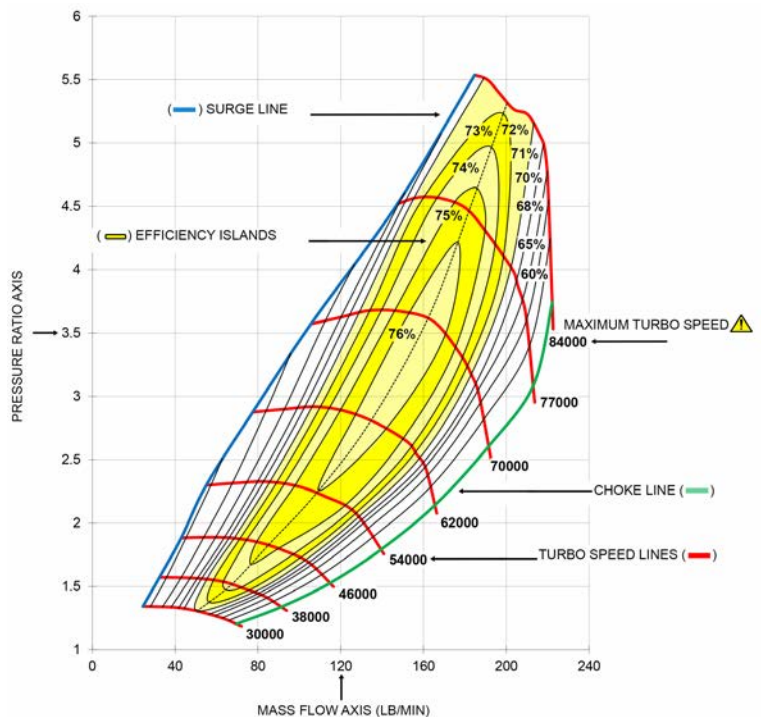

A/R (Area/Radius) describes a geometric characteristic of all compressor and turbine housings. It is defined as the inlet (or, for compressor housings, the discharge) cross-sectional area divided by the radius from the turbo centerline to the centroid of that area.

Compressor A/R - Compressor performance is comparatively insensitive to changes in A/R. Larger A/R housings are sometimes used to optimize performance of low boost applications, and smaller A/R are used for high boost applications. However, as this influence of A/R on compressor performance is minor, there are rarely A/R options available for compressor housings.

Turbine A/R - Turbine performance is greatly affected by changing the A/R of the housing. Using a smaller A/R will increase the exhaust gas velocity into the turbine wheel providing increased turbine power at lower engine speeds and resulting in quicker boost response. The smaller A/R also causes the flow to enter the wheel more tangentially, which reduces the ultimate flow capacity of the turbine wheel. This will increase exhaust back pressure and reduce the engine's ability to breathe effectively at high RPM, adversely affecting peak engine power.

Using a larger A/R will lower exhaust gas velocity, and delay boost response. The flow in a larger A/R housing enters the wheel in a more radial fashion, increasing the wheel's effective flow capacity, resulting in lower back pressure and more power at higher engine speeds.

When deciding between A/R options, be realistic with the intended vehicle use and choose the A/R to bias the performance toward the desired power band characteristic.

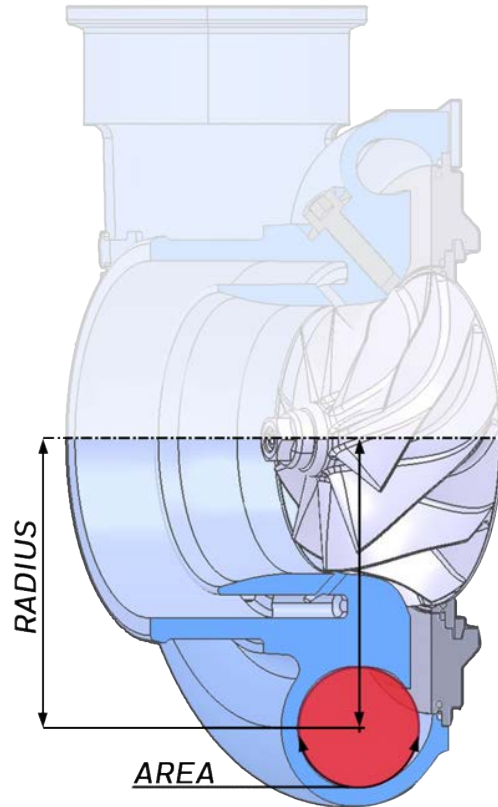

HOW DO I CHOOSE THE RIGHT TURBO

The primary input in determining which turbocharger is appropriate is to have a target horsepower in mind. This should be as realistic as possible for the application. Remember that engine power is generally proportional to air and fuel flow. Once you have a target horsepower identified along with your engine displacement, you begin to hone in on the turbocharger size, which is highly dependent on airflow requirements.

Other important factors include the type of application. An autocross car, for example, requires rapid boost response. A smaller turbocharger or smaller turbine housing would be most suitable for this application. While this will trade off ultimate power due to increased exhaust back pressure at higher engine speeds, boost response of the small turbo will be excellent. Alternatively, on a car dedicated to track days, peak horsepower is a higher priority than low-end torque. Plus, engine speeds tend to be consistently higher. Here, a larger turbocharger or turbine housing will provide reduced back pressure but less-immediate low-end response. This is a welcome trade off given the intended operating conditions.

Selecting the turbocharger for your application goes beyond "how much boost" you want to run. Defining your target power level and the primary use for the application are the first steps in enabling your Performance Distributor to select the right turbocharger for you.

Scan the QR codes below to be directed to the Garrett distributor locator or the Boost Adviser turbo matching tool.



Distributor Locator



Boost Adviser

Turbocharger part numbers are offered in four configurations and it is important to understand the differences when ordering part numbers. This guide will explain the differences. If you have any questions, please contact a Garrett Distributor for more information.

Supercore PN

Supercore refers to a rotating assembly with compressor housing attached. Gasket kit included. Turbine housing not included.

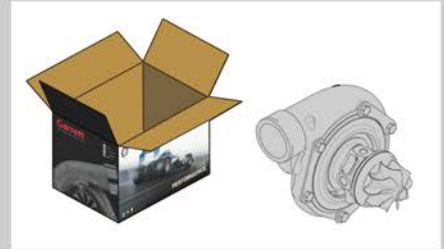

Turbine Kit PN

Individually packaged turbine exhaust housings. Connections and size vary between models. Gasket kit, bolts, clamps, V-band/s included. Weld flanges are not included

- Reverse rotation turbine housings are **not** interchangeable with standard rotation supercores
- GT | GTX | GTX Gen II turbine housings **are** interchangeable within the frame family. (GT30 | GTX30 | GTX30 Gen II)
- G-Series housings are **not** interchangeable with GT | GTX | GTW
- GTW housings are **not** interchangeable with GT | GTX | G-Series
- Some options may require modifications to the exhaust system to fit
- Always double check before purchasing



Turbo PN

Supercore and turbine housing are fully assembled and calibrated by Garrett with a 0.5 Bar actuator. The assembly and calibration make it a Turbo. Only offered with internally wastegated turbine housings. Gasket kit is included.

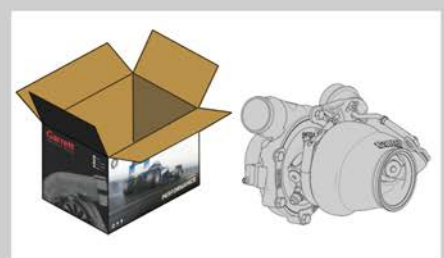

Assembly Kit PN

One part number includes the supercore and turbine kit, in individual boxes, not assembled to make ordering easier. Gasket kit included. Tools and assembly required to connect the supercore to the turbine housing.



G-SERIES II

Whether you're a kit maker or an owner of a high-performance vehicle, now you can harness the power of motorsport legends and experience the durability of champions in your car with the NEW G-Series II universal Performance Turbos line from Garrett. Designed with the same quality and craftsmanship that has powered motorsport legends for over 4 decades. G-Series II turbochargers are available in multiple frame sizes to suit your individual needs, whether as a complete new turbo or as a CHRA swap to upgrade your G-Series I Turbo.



Power Of Legends. Durability Of Champions.

Only the best of the best qualify to compete in prestigious Motorsport races, like the 24 Hours of Le Mans. It takes a combination of unparalleled skill, relentless hard work, and cutting-edge technology to reach the podium and achieve immortality. Those who succeed become legends.

For over 40 years, Garrett has been the name behind the legends of motorsport, powering the winners of the most prestigious races, including the Le Mans champions of the last 25 years. Our turbochargers are engineered by a team of 1300 engineers and tested across five R&D centers around the world, to deliver unmatched performance and reliability.



G-Series II G25-585

Horsepower: 300 - 585
Displacement: 1.4L - 3.0L

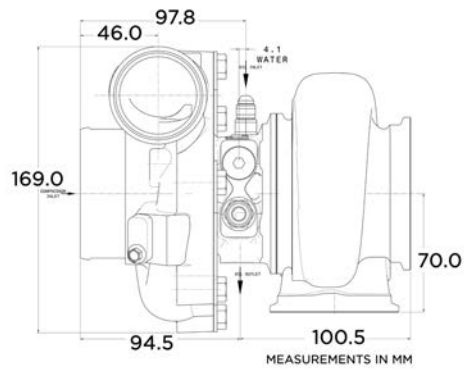

INTERNALLY WASTEGATED

REVERSE ROTATION

COMPRESSOR MAP

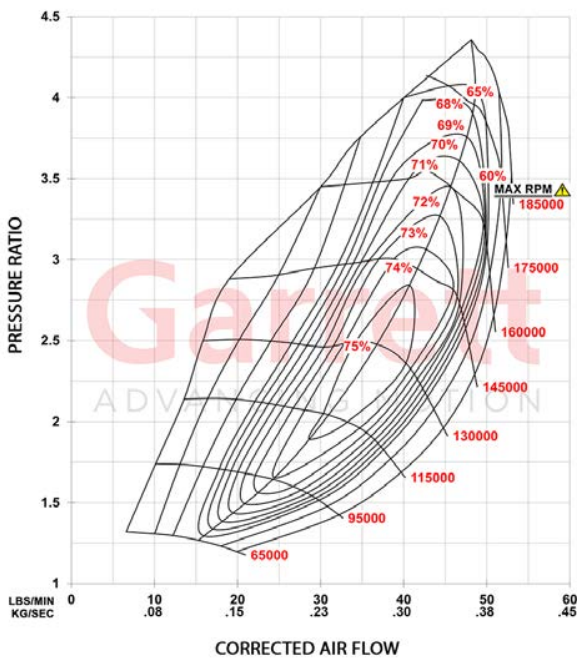

FEATURES:

- ◆ NEW COMPRESSOR AERO INCREASES POWER AND PERFORMANCE
- ◆ UP TO 10% HIGHER COMPRESSOR FLOW COMPARED TO G-SERIES GEN I AT PEAK PRESSURE RATIO AND PEAK TURBO RPM
- ◆ DIRECT UPGRADE PATH FOR GEN I CUSTOMERS WITH JUST A CHRA SWAP
- ◆ UTILIZES GEN I COMPRESSOR AND TURBINE HOUSINGS
- ◆ STANDARD AND REVERSE ROTATION CONFIGURATIONS
- ◆ TURBINE WHEEL CONSTRUCTED OF MAR-M ALLOY RATED UP TO 1050°C
- ◆ OIL RESTRICTOR AND WATER FITTINGS INCLUDED

EXHAUST FLOW CHART

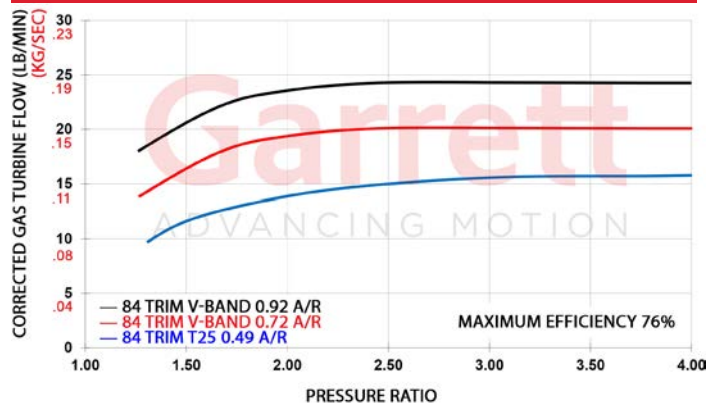

G-Series II G25-585	Compressor				Turbine		
	Inducer	Exducer	Trim	A/R	Inducer	Exducer	Trim
HP: 300-585 Disp: 1.4L-3.0L	48mm	60mm	65	0.70	54mm	49mm	84
Supercore	PN						
Standard Rotation	934075-5001S						
Reverse Rotation	934114-5001S						
CHRA	PN						
Standard Rotation	934074-5001S						
Reverse Rotation	934113-5001S						
Turbo: Standard Rotation	PN	A/R	Inlet	Outlet	Wastegate	Divided	
Assembled and calibrated	934076-5001S	0.49	T25	V-Band	Internal	N	
with 0.5 bar actuator	934076-5002S	0.72	V-Band	V-Band	Internal	N	
	934076-5003S	0.92	V-Band	V-Band	Internal	N	
Turbo: Reverse Rotation	PN	A/R	Inlet	Outlet	Wastegate	Divided	
See note above	934115-5001S	0.72	V-Band	V-Band	Internal	N	
	934115-5002S	0.92	V-Band	V-Band	Internal	N	
Turbine Kits Standard Rotation	PN	A/R	Inlet	Outlet	Wastegate	Divided	
	740902-0069	0.72	V-Band	V-Band	External	N	
	740902-0068	0.92	V-Band	V-Band	External	N	
	740902-0076	0.72	V-Band	V-Band	Internal	N	
	740902-0077	0.92	V-Band	V-Band	Internal	N	
	740902-0080	0.49	T25	V-Band	Internal	N	
Turbine Kits Reverse Rotation	PN	A/R	Inlet	Outlet	Wastegate	Divided	
	740902-0073	0.72	V-Band	V-Band	External	N	
	740902-0074	0.92	V-Band	V-Band	External	N	
	740902-0078	0.72	V-Band	V-Band	Internal	N	
	740902-0079	0.92	V-Band	V-Band	Internal	N	

G-Series II G25-700

Horsepower: 350 - 700
Displacement: 1.4L - 3.0L

Garrett
ADVANCING MOTION

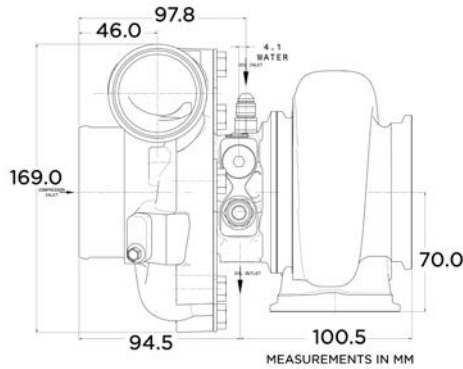

COMPRESSOR MAP

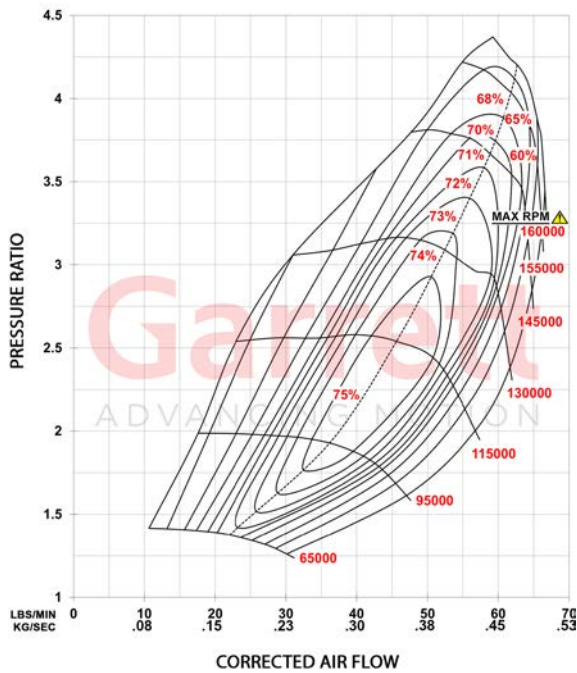

FEATURES:

- ◆ NEW COMPRESSOR AERO INCREASES POWER AND PERFORMANCE
- ◆ UP TO 10% HIGHER COMPRESSOR FLOW COMPARED TO G-SERIES GEN I AT PEAK PRESSURE RATIO AND PEAK TURBO RPM
- ◆ DIRECT UPGRADE PATH FOR GEN I CUSTOMERS WITH JUST A CHRA SWAP
- ◆ UTILIZES GEN I COMPRESSOR AND TURBINE HOUSINGS
- ◆ STANDARD AND REVERSE ROTATION CONFIGURATIONS
- ◆ TURBINE WHEEL CONSTRUCTED OF MAR-M ALLOY RATED UP TO 1050°C
- ◆ OIL RESTRICTOR AND WATER FITTINGS INCLUDED

EXHAUST FLOW CHART

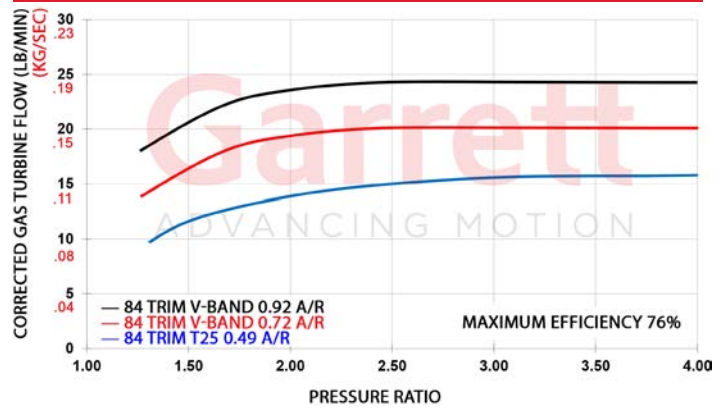

G-Series II G25-700	Compressor				Turbine		
	Inducer	Exducer	Trim	A/R	Inducer	Exducer	Trim
HP: 350-700 Disp: 1.4L-3.0L	54mm	67mm	65	0.70	54mm	49mm	84
Supercore	PN						
Standard Rotation	934075-5002S						
Reverse Rotation	934114-5002S						
CHRA	PN						
Standard Rotation	934074-5002S						
Reverse Rotation	934113-5002S						
Turbo: Standard Rotation	PN	A/R	Inlet	Outlet	Wastegate	Divided	
Assembled and calibrated with 0.5 bar actuator	934076-5004S	0.49	T25	V-Band	Internal	N	
	934076-5005S	0.72	V-Band	V-Band	Internal	N	
	934076-5006S	0.92	V-Band	V-Band	Internal	N	
Turbo: Reverse Rotation	PN	A/R	Inlet	Outlet	Wastegate	Divided	
See note above	934115-5003S	0.72	V-Band	V-Band	Internal	N	
	934115-5004S	0.92	V-Band	V-Band	Internal	N	
Turbine Kits Standard Rotation	PN	A/R	Inlet	Outlet	Wastegate	Divided	
	740902-0069	0.72	V-Band	V-Band	External	N	
	740902-0068	0.92	V-Band	V-Band	External	N	
	740902-0076	0.72	V-Band	V-Band	Internal	N	
	740902-0077	0.92	V-Band	V-Band	Internal	N	
	740902-0080	0.49	T25	V-Band	Internal	N	
Turbine Kits Reverse Rotation	PN	A/R	Inlet	Outlet	Wastegate	Divided	
	740902-0073	0.72	V-Band	V-Band	External	N	
	740902-0074	0.92	V-Band	V-Band	External	N	
	740902-0078	0.72	V-Band	V-Band	Internal	N	
	740902-0079	0.92	V-Band	V-Band	Internal	N	

G-Series II G30-725

Horsepower: 350 - 725
Displacement: 2.0L - 3.5L

Garrett
ADVANCING MOTION

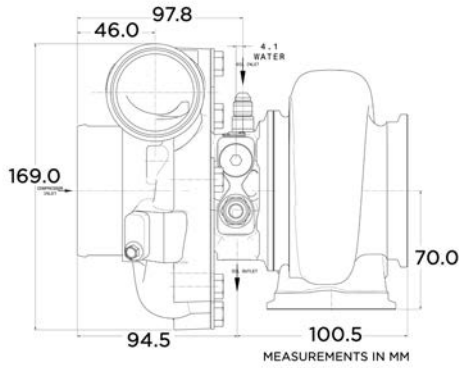

COMPRESSOR MAP

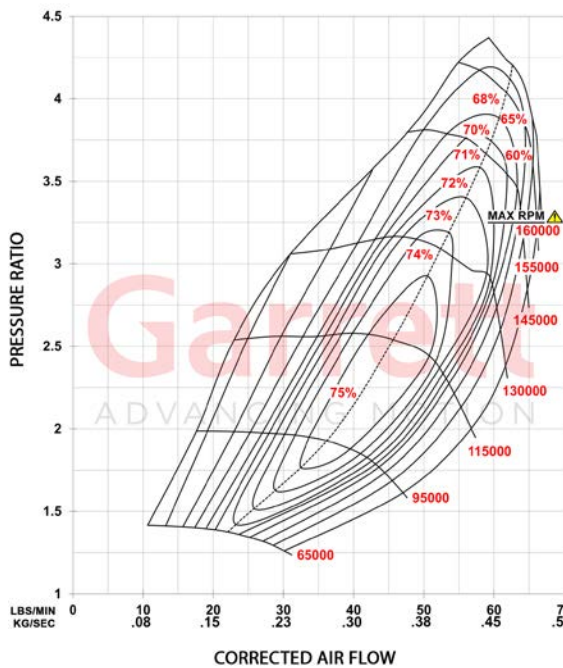

FEATURES:

- ◆ NEW COMPRESSOR AERO INCREASES POWER AND PERFORMANCE
- ◆ UP TO 10% HIGHER COMPRESSOR FLOW COMPARED TO G-SERIES GEN I AT PEAK PRESSURE RATIO AND PEAK TURBO RPM
- ◆ DIRECT UPGRADE PATH FOR GEN I CUSTOMERS WITH JUST A CHRA SWAP
- ◆ UTILIZES GEN I COMPRESSOR AND TURBINE HOUSINGS
- ◆ STANDARD AND REVERSE ROTATION CONFIGURATIONS
- ◆ TURBINE WHEEL CONSTRUCTED OF MAR-M ALLOY RATED UP TO 1050°C
- ◆ OIL RESTRICTOR AND WATER FITTINGS INCLUDED

EXHAUST FLOW CHART

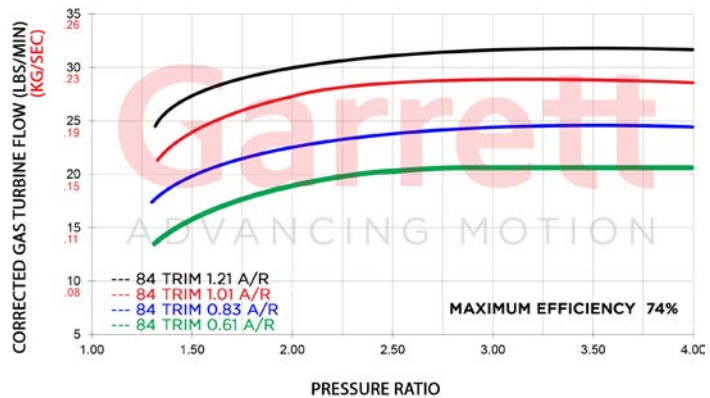

G-Series II G30-725	Compressor				Turbine					
	HP: 350-725	Disp: 2.0L-3.5L	Inducer	Exducer	Trim	A/R	Inducer	Exducer	Trim	
			54mm	67mm	65	0.70	60mm	55mm	84	
Supercore										
			PN							
			934117-5001S							
			934121-5001S							
CHRA										
			PN							
			934116-5001S							
			934120-5001S							
Turbo: Standard Rotation										
					PN	A/R	Inlet	Outlet	Wastegate	Divided
					Assembled and calibrated with 0.5 bar actuator	0.83	V-Band	V-Band	Internal	N
					934118-5002S	1.01	V-Band	V-Band	Internal	N
Turbine Kits Standard Rotation										
					PN	A/R	Inlet	Outlet	Wastegate	Divided
					740902-0092	1.06	T4	V-Band	External	Y
					740902-0090	0.83	T3	V-Band	External	N
					740902-0091	1.01	T3	V-Band	External	N
					740902-0086	0.61	V-Band	V-Band	External	N
					740902-0087	0.83	V-Band	V-Band	External	N
					740902-0088	1.01	V-Band	V-Band	External	N
					740902-0089	1.21	V-Band	V-Band	External	N
					740902-0094	0.83	V-Band	V-Band	Internal	N
					740902-0095	1.01	V-Band	V-Band	Internal	N
Turbine Kits Reverse Rotation										
					PN	A/R	Inlet	Outlet	Wastegate	Divided
					740902-0100	0.83	T3	V-Band	External	N
					740902-0101	1.01	T3	V-Band	External	N
					740902-0096	0.61	V-Band	V-Band	External	N
					740902-0097	0.83	V-Band	V-Band	External	N
					740902-0098	1.01	V-Band	V-Band	External	N
					740902-0099	1.21	V-Band	V-Band	External	N

G-Series II G30-825

Horsepower: 475 - 825
Displacement: 2.0L - 3.5L

Garrett
ADVANCING MOTION

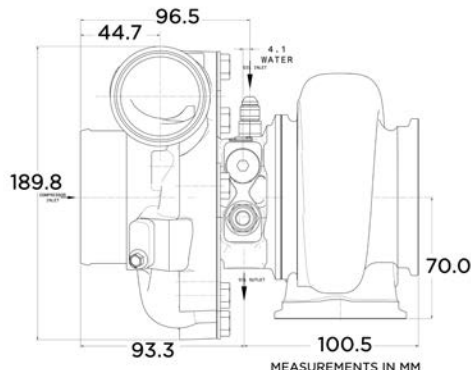

FEATURES:

- ◆ NEW COMPRESSOR AERO INCREASES POWER AND PERFORMANCE
- ◆ UP TO 10% HIGHER COMPRESSOR FLOW COMPARED TO G-SERIES GEN I AT PEAK PRESSURE RATIO AND PEAK TURBO RPM
- ◆ DIRECT UPGRADE PATH FOR GEN I CUSTOMERS WITH JUST A CHRA SWAP
- ◆ UTILIZES GEN I COMPRESSOR AND TURBINE HOUSINGS
- ◆ STANDARD AND REVERSE ROTATION CONFIGURATIONS
- ◆ TURBINE WHEEL CONSTRUCTED OF MAR-M ALLOY RATED UP TO 1050°C
- ◆ OIL RESTRICTOR AND WATER FITTINGS INCLUDED

COMPRESSOR MAP

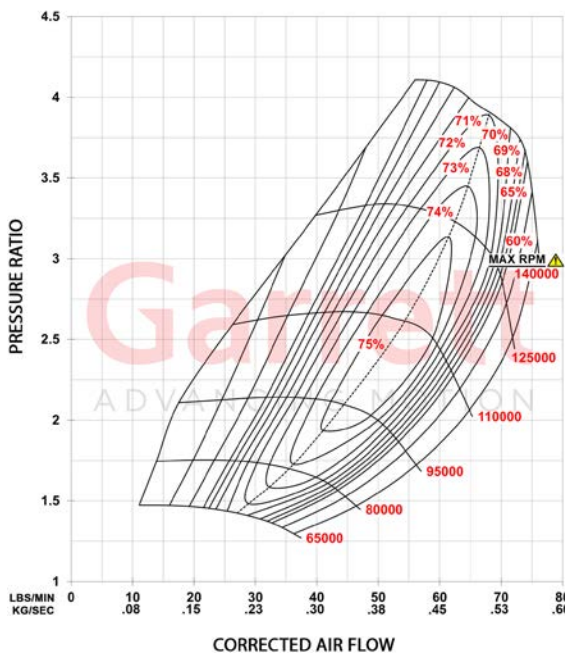

EXHAUST FLOW CHART

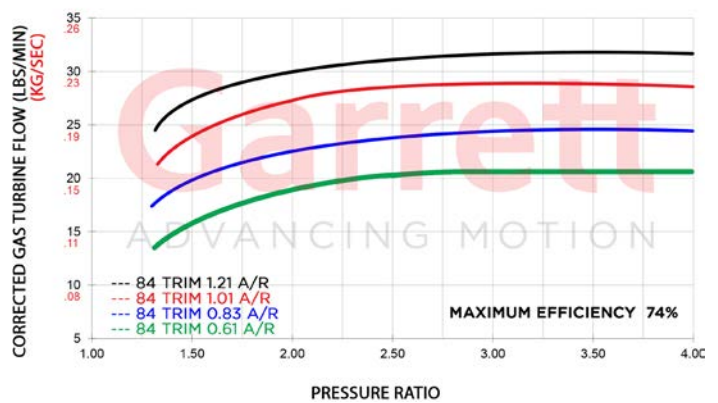

G-Series II G30-825	Compressor				Inducer	Turbine	Trim
	Inducer	Exducer	Trim	A/R			
HP: 475-825 Disp: 2.0L-3.5L	58mm	71mm	65	0.72	60mm	55mm	84
Supercore	PN						
Standard Rotation	934117-5002S						
Reverse Rotation	934121-5002S						
CHRA	PN						
Standard Rotation	934116-5002S						
Reverse Rotation	934120-5002S						
Turbo: Standard Rotation	PN	A/R	Inlet	Outlet	Wastegate	Divided	
Assembled and calibrated with 0.5 bar actuator	934118-5003S	0.83	V-Band	V-Band	Internal	N	
	934118-5004S	1.01	V-Band	V-Band	Internal	N	
Turbine Kits Standard Rotation	PN	A/R	Inlet	Outlet	Wastegate	Divided	
	740902-0092	1.06	T4	V-Band	External	Y	
	740902-0090	0.83	T3	V-Band	External	N	
	740902-0091	1.01	T3	V-Band	External	N	
	740902-0086	0.61	V-Band	V-Band	External	N	
	740902-0087	0.83	V-Band	V-Band	External	N	
	740902-0088	1.01	V-Band	V-Band	External	N	
	740902-0089	1.21	V-Band	V-Band	External	N	
	740902-0094	0.83	V-Band	V-Band	Internal	N	
	740902-0095	1.01	V-Band	V-Band	Internal	N	
Turbine Kits Reverse Rotation	PN	A/R	Inlet	Outlet	Wastegate	Divided	
	740902-0100	0.83	T3	V-Band	External	N	
	740902-0101	1.01	T3	V-Band	External	N	
	740902-0096	0.61	V-Band	V-Band	External	N	
	740902-0097	0.83	V-Band	V-Band	External	N	
	740902-0098	1.01	V-Band	V-Band	External	N	
	740902-0099	1.21	V-Band	V-Band	External	N	

G-Series II G35-990

Horsepower: 550 - 990
Displacement: 2.0L - 5.5L

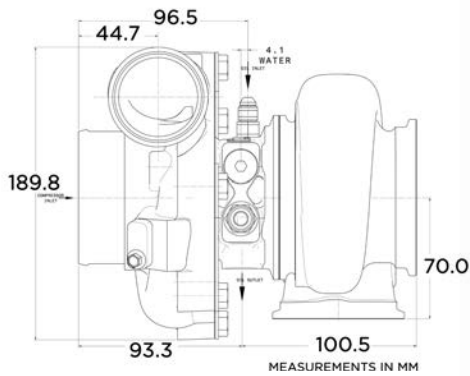

COMPRESSOR MAP

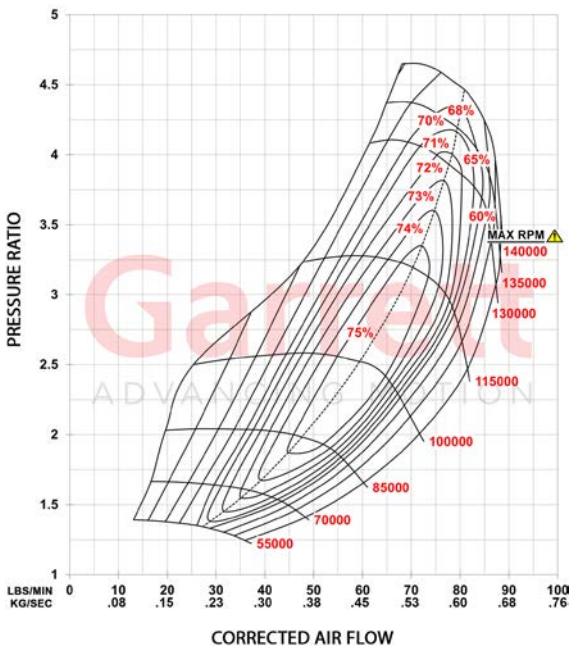

FEATURES:

- ◆ NEW COMPRESSOR AERO INCREASES POWER AND PERFORMANCE
- ◆ UP TO 10% HIGHER COMPRESSOR FLOW COMPARED TO G-SERIES GEN I AT PEAK PRESSURE RATIO AND PEAK TURBO RPM
- ◆ DIRECT UPGRADE PATH FOR GEN I CUSTOMERS WITH JUST A CHRA SWAP
- ◆ UTILIZES GEN I COMPRESSOR AND TURBINE HOUSINGS
- ◆ STANDARD AND REVERSE ROTATION CONFIGURATIONS
- ◆ TURBINE WHEEL CONSTRUCTED OF MAR-M ALLOY RATED UP TO 1050°C
- ◆ OIL RESTRICTOR AND WATER FITTINGS INCLUDED

EXHAUST FLOW CHART

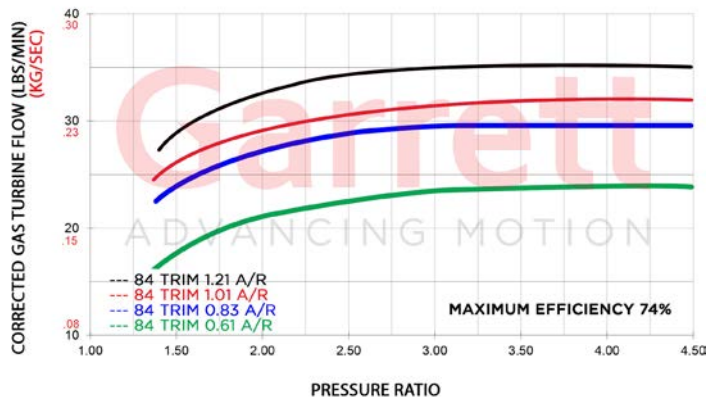

G-Series II G35-990		Compressor				Turbine		
HP: 550-990	Disp: 2.0L-5.5L	Inducer	Exducer	Trim	A/R	Inducer	Exducer	Trim
		62mm	76mm	65	0.72	68mm	62mm	84
Supercore		PN						
Standard Rotation		934123-5001S						
Reverse Rotation		934126-5001S						
CHRA		PN						
Standard Rotation		934122-5001S						
Reverse Rotation		934125-5001S						
Turbo: Standard Rotation		PN		A/R	Inlet	Outlet	Wastegate	Divided
Assembled and calibrated		934124-5001S		0.83	V-Band	V-Band	Internal	N
with 0.5 bar actuator		934124-5002S		1.01	V-Band	V-Band	Internal	N
Turbine Kits Standard Rotation		PN		A/R	Inlet	Outlet	Wastegate	Divided
		740902-0108		1.06	T4	V-Band	External	Y
		740902-0106		0.83	T3	V-Band	External	N
		740902-0107		1.01	T3	V-Band	External	N
		740902-0102		0.61	V-Band	V-Band	External	N
		740902-0103		0.83	V-Band	V-Band	External	N
		740902-0104		1.01	V-Band	V-Band	External	N
		740902-0105		1.21	V-Band	V-Band	External	N
		740902-0110		0.83	V-Band	V-Band	Internal	N
		740902-0111		1.01	V-Band	V-Band	Internal	N
Turbine Kits Reverse Rotation		PN		A/R	Inlet	Outlet	Wastegate	Divided
		740902-0116		0.83	T3	V-Band	External	N
		740902-0117		1.01	T3	V-Band	External	N
		740902-0112		0.61	V-Band	V-Band	External	N
		740902-0113		0.83	V-Band	V-Band	External	N
		740902-0114		1.01	V-Band	V-Band	External	N
		740902-0115		1.21	V-Band	V-Band	External	N



G-SERIES

Garrett G-Series turbochargers feature the latest innovations in turbocharger technology. This clean sheet product has our highest performing compressor and turbine aero to date. Countless engineering hours have been spent to create the perfect blend of efficiency and performance in a compact package. Advanced features tailored to meet the demands of hard core competitors making G-Series the most powerful turbochargers on the market.



The AMS Performance Prime Cuts Chop Shop ALPHA OMEGA Huracan project was started with one goal in mind, to build the world's fastest Lamborghini. As an authorized Performance Distributor of Garrett Motion, AMS has firsthand testing data and on-track experience to know what works and what doesn't. The car has utilized a number of different Garrett turbos throughout its stages to meet the horsepower needs to go faster and faster. From GTX3584RS, G35-1050, G42-1200 Compact, and now a pair of G42-1450 turbos with a 79mm compressor which allows the car to make over **2000 wheel horsepower**.

AMS PERFORMANCE - Prime Cuts Chop Shop Alpha Omega Drag Huracan



Reliability is always a priority when working in a competitive racing environment. With an entire race team, vehicle transporter, tools, tires, consumables, and more sent to support the vehicle at race events across the country, teams cannot afford to sit on the sidelines due to a mechanical failure. The testing and inspection procedures that Garrett implements in their manufacturing processes are second to none in the industry and is why they are well known as offering the most reliable turbocharger solutions on the market. This reliability has allowed the AMS team to remain competitive in numerous events as well as set the world record of 7.33 sec @ 194 mph quarter mile with the ALPHA OMEGA Huracan.

A TURN AHEAD OF THE COMPETITION



Product Features	G25-550	G25-660	G30-660	G30-770	G30-900	G35-900	G35-1050	G40-900	G40-1150	G42-1200C	G42-1200	G42-1450	G45-1125	G45-1350	G45-1500	G45-1600
Displacement Range	1.4L-3.0L		2.0L-3.5L			2.0L-5.5L		2.0L-6.0L		2.0L-7.0L			2.0L-8.0L			
Turbine Inducer	54mm		60mm			68mm		77mm		82mm			89mm			
Turbine Exducer	49mm		55mm			62mm		70mm		75mm			82mm			
Horsepower Range	300-550	350-660	350-660	475-770	550-900	550-900	700-1050	500-900	500-1150	475-1200	475-1200	525-1450	600-1125	650-1350	750-1500	750-1600
Comp Ind (mm)	48	54	54	58	62	62	68	62	71	73	73	79	67	72	76	80
Comp Exd (mm)	60	67	67	71	76	76	84	88	88	91	91	98	102	102	109	109
Standard Rotation	*	*	*	*	*	*	*	*	*	*	*	*	*	*	*	*
Reverse Rotation	*	*	*	*	*	*	*	*	*	*	*	*	*	*	*	*
Internally Wastegated Options	*	*	*	*	*	*	*	*	*	*	*	*	*	*	*	*
Speed Sensor Port	*	*	*	*	*	*	*	*	*	*	*	*	*	*	*	*
Water Cooled	*	*	*	*	*	*	*	*	*	*	*	*	*	*	*	*
Dual Ceramic Ball Bearing	*	*	*	*	*	*	*	*	*	*	*	*	*	*	*	*
Machined Pressure Port	*	*	*	*	*	*	*	*	*	*	*	*	*	*	*	*
Twin Piston Rings	*	*	*	*	*	*	*	*	*	*	*	*	*	*	*	*
Ported Shroud	*	*	*	*	*	*	*	*	*	*	*	*	*	*	*	*
Stainless Steel Turbine Housing	*	*	*	*	*	*	*	*	*	*	*	*	*	*	*	*
Inconel Turbine Wheel	*	*	*	*	*	*	*	*	*	*	*	*	*	*	*	*
Mar-M Turbine Wheel	*	*	*	*	*	*	*	*	*	*	*	*	*	*	*	*
T25 Inlet Turbine Housing	*	*	*	*	*	*	*	*	*	*	*	*	*	*	*	*
V-Band 3"176mm Inlet Turbine	*	*	*	*	*	*	*	*	*	*	*	*	*	*	*	*
T3 Inlet Turbine Housing	*	*	*	*	*	*	*	*	*	*	*	*	*	*	*	*
T4 Divided Inlet Turbine Housing	*	*	*	*	*	*	*	*	*	*	*	*	*	*	*	*
V-Band 3.6"192mm Inlet Turbine	*	*	*	*	*	*	*	*	*	*	*	*	*	*	*	*
T6 Inlet Turbine Housing	*	*	*	*	*	*	*	*	*	*	*	*	*	*	*	*
V-Band 4.25"1108mm Inlet Turbine	*	*	*	*	*	*	*	*	*	*	*	*	*	*	*	*

INTERNALLY WASTEGATED

configurations are available in standard rotation in G25|G30|G35 and reverse rotation in G25. Turbochargers are fully assembled and calibrated with a 0.5 bar actuator.



STANDARD AND REVERSE ROTATION

turbochargers are offered in the G-Series product line up to G35 frame sizes. Reverse rotation turbochargers are mirrored in appearance and rotate counter clockwise. It is a popular option for twin turbo systems to maintain symmetry in the engine compartment. Reverse rotation components are not interchangeable with standard rotation components and housings. G25 | G30 | G35





	G47-1550	G47-1650	G47-1650	G47-1850	G50-1700	G50-1900	G55-1850	G55-1950	G55-2100	G55-2250	G55-2450	G55-2650	G55-2900	G57-2000	G57-2350	G57-2550	G57-2750	G57-3000
	2.5L-10.0L				2.5L-11.0L		3.0L-12.0L						3.0L-12.0L					
	93mm				99mm		112mm						118mm					
	88mm				94mm		106mm						112mm					
1	825-1550	825-1650	825-1650	825-1850	875-1700	875-1900	1000-1850	1000-1950	1000-2100	1000-2250	1000-2450	1000-2650	1000-2900	1400-2000	1400-2350	1400-2550	1400-2750	1400-3000
0	76	80	80	88	80	88	85	88	91	94	98	102	106	88	94	98	102	106
9	109	109	120	120	109	120	133	133	133	133	133	144	144	133	133	133	144	144
	*	*	*	*	*	*	*	*	*	*	*	*	*	*	*	*	*	*
	*	*	*	*	*	*	*	*	*	*	*	*	*	*	*	*	*	*
	*	*	*	*	*	*	*	*	*	*	*	*	*	*	*	*	*	*
	*	*	*	*	*	*	*	*	*	*	*	*	*	*	*	*	*	*
	*	*	*	*	*	*	*	*	*	*	*	*	*	*	*	*	*	*
	*	*	*	*	*	*	*	*	*	*	*	*	*	*	*	*	*	*
	*	*	*	*	*	*	*	*	*	*	*	*	*	*	*	*	*	*
	*	*	*	*	*	*	*	*	*	*	*	*	*	*	*	*	*	*
	*	*	*	*	*	*	*	*	*	*	*	*	*	*	*	*	*	*
	*	*	*	*	*	*	*	*	*	*	*	*	*	*	*	*	*	*
	*	*	*	*	*	*	*	*	*	*	*	*	*	*	*	*	*	*
	*	*	*	*	*	*	*	*	*	*	*	*	*	*	*	*	*	*
	*	*	*	*	*	*	*	*	*	*	*	*	*	*	*	*	*	*
	*	*	*	*	*	*	*	*	*	*	*	*	*	*	*	*	*	*
	*	*	*	*	*	*	*	*	*	*	*	*	*	*	*	*	*	*
	*	*	*	*	*	*	*	*	*	*	*	*	*	*	*	*	*	*
	*	*	*	*	*	*	*	*	*	*	*	*	*	*	*	*	*	*
	*	*	*	*	*	*	*	*	*	*	*	*	*	*	*	*	*	*
	*	*	*	*	*	*	*	*	*	*	*	*	*	*	*	*	*	*
	*	*	*	*	*	*	*	*	*	*	*	*	*	*	*	*	*	*

STAINLESS STEEL TURBINE HOUSINGS

are offered with all G-Series turbochargers. High heat tolerance paired with high strength make a robust product that looks great and passes Garrett Motion burst and containment testing.



TWIN PISTON RINGS

on both sides of the shaft combined with a new oil deflector to help reduce oil leakage from the center housing to the compressor and turbine stages.



SEAL PLATE

OIL DEFLECTOR

THRUST SHROUD

BEARING CARTRIDGE

Ceramic dual ball bearings in a compact cartridge result in less heat transfer to the oil. Steel bearing cages improve the durability of the rotating assembly.



COMPRESSOR WHEEL

Forged fully-machined with new aerodynamics to increase flow up 30% more air than other Garrett turbos.





"We have been able to capture **24** total track records"

C6 Corvette featured on the cover page

10 Questions with Feras Qartoumy:

1. What made you decide to start racing?

I grew up at the track watching my father race. He would take me with him to help change tires and brakes. I probably did more harm than good but thanks to my father I not only developed a passion for racing but it's also where I got my mindset of never giving up!

2. Tell us about your Corvette (YMM, engine, power, turbos, etc.)

2008 Corvette Z06. LME 427. RHS Block Brodix Heads. Garrett G35-900's 1200 whp on kill... Penske Racing 8300's Alcon 6 piston Brakes Front 4 piston Rear. Motec M150 PPG 1:1 6th gear sequential. Yokohama A005 tires. Bosch Motorsport ABS

3. You have made a big name for yourself the last 2 years. Tell us about all the accomplishments.

The past two years have been absolutely unbelievable. With the help from all my amazing partners we have been able to capture 24 total track records in 2020 and 2021 combined! We were also able to place 1st at every event but 1!

4. Do you have a favorite memory?

My favorite memory would have to be capturing the production car record at Road America with a 2:04. The car was overheating by turn 5 and somehow allowed me to keep pushing and finish the lap. Made me feel like both myself and the car wanted it and stuck it out till the end.

5. What is your favorite race track?

Hands down Circuit of the Americas

6. What tips would you give someone who is just starting out in racing?

Have fun. Many people take racing too serious. Never lose sight of how lucky you are to be on track and doing something you are passionate about.

7. Tell us what you like about the different turbo combos and how they have helped you in different ways?

What I like mostly about them is how easily interchangeable they are. I was able to literally just swap turbos and not have to change hot side or charge piping I think that for one making it so easy to test and change out turbos per event is amazing. Also I have noticed I can reach my target HP very easily with all. And can spool sooner by stepping down from a g 35-900 to a g 30-900 but yet still have all the tq and hp I want up top. The g35 seems to be best suited for bigger tracks that have higher speed turns and longer straights. Where the g30 is utilized in smaller tracks where lower speeds are not allowing the turbos to spool as quickly.

8. Your car has some serious aero, how much downforce does it make and how do you know when to adjust it for different tracks?

Currently the car is making north of 3200 lbs of downforce. I have been making slight adjustment to the car per event. I have seen gains and the pros of using high df but also seen cons. That is why at Long Beach and Road America I opted to use a medium downforce package. I am in the process of designing aero with Verus specific to the car based on the data I have acquired over this past year. We just finished scanning the car and have ran it through a few sims now. Big things to come...

9. What's in store for 2022?

For 2022 I'd love to start traveling outside the us and make my way to Australia. I plan on adding to my list of track records and hopefully claim a few more national titles. We have some new aero we are developing in CAD and hopefully a bit more power...

10. Where can people find you on social media?

I pretty much do everything on Instagram. You can find me at @feras_qartoumy I post almost all my in-car on YouTube at Feras Qartoumy.

Garrett G25-550

Horsepower: 300 - 550
Displacement: 1.4L - 3.0L

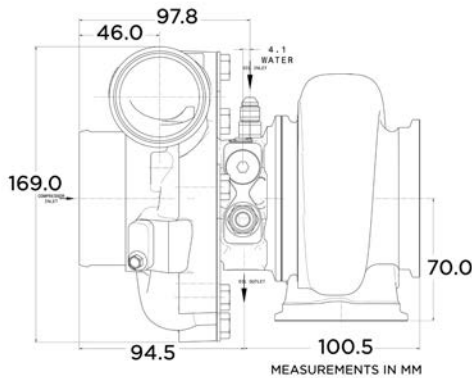

COMPRESSOR MAP

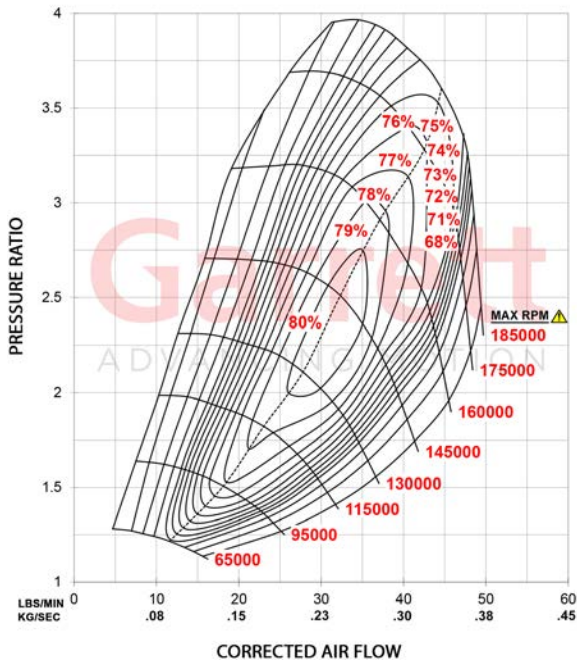

FEATURES:

- ◆ G-SERIES COMPRESSOR AERODYNAMICS FOR MAXIMUM HP
- ◆ G-SERIES TURBINE WHEEL AERO WITH IMPROVED EFFICIENCY
- ◆ STANDARD AND REVERSE ROTATION CONFIGURATIONS
- ◆ TURBINE WHEEL CONSTRUCTED OF MAR-M ALLOY RATED UP TO 1050°C
- ◆ FULLY MACHINED SPEED SENSOR AND PRESSURE PORTS
- ◆ OIL RESTRICTOR AND WATER FITTINGS INCLUDED

EXHAUST FLOW CHART

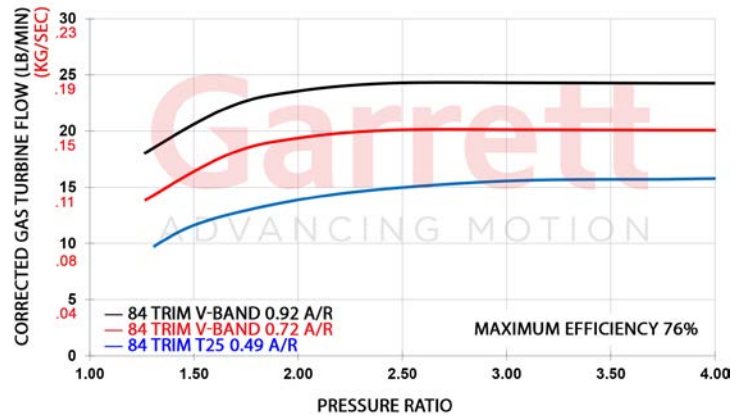

G25-550 HP: 300-550 Disp: 1.4L-3.0L	Compressor				Turbine		
	Inducer	Exducer	Trim	A/R	Inducer	Exducer	Trim
Turbo: Standard Rotation	48mm	60mm	65	0.70	54mm	49mm	84
Assembled and calibrated with 0.5 bar actuator	PN	PN	A/R	Inlet	Outlet	Wastegate	Divided
	877895-5001S		0.49	T25	V-Band	Internal	N
	877895-5003S		0.72	V-Band	V-Band	Internal	N
	877895-5004S		0.92	V-Band	V-Band	Internal	N
Turbo: Reverse Rotation	PN	PN	A/R	Inlet	Outlet	Wastegate	Divided
See note above	877895-5007S		0.72	V-Band	V-Band	Internal	N
	877895-5008S		0.92	V-Band	V-Band	Internal	N
Turbine Kits Standard Rotation	PN	PN	A/R	Inlet	Outlet	Wastegate	Divided
Internal Wastegate	740902-0076		0.72	V-Band	V-Band	Internal	N
	740902-0077		0.92	V-Band	V-Band	Internal	N
	740902-0080		0.49	T25	V-Band	Internal	N
Turbine Kits Reverse Rotation	PN	PN	A/R	Inlet	Outlet	Wastegate	Divided
Internal Wastegate	740902-0078		0.72	V-Band	V-Band	Internal	N
	740902-0079		0.92	V-Band	V-Band	Internal	N
Supercore	PN	PN	A/R	Inlet	Outlet	Wastegate	Divided
Standard Rotation	858161-5002S						
Reverse Rotation	871388-5001S						
Turbine Kits Standard Rotation	PN	PN	A/R	Inlet	Outlet	Wastegate	Divided
Free Float	740902-0069		0.72	V-Band	V-Band	External	N
	740902-0068		0.92	V-Band	V-Band	External	N
Turbine Kits Reverse Rotation	PN	PN	A/R	Inlet	Outlet	Wastegate	Divided
Free Float	740902-0073		0.72	V-Band	V-Band	External	N
	740902-0074		0.92	V-Band	V-Band	External	N

Garrett G25-660

Horsepower: 350 - 660
Displacement: 1.4L - 3.0L

Garrett
ADVANCING MOTION

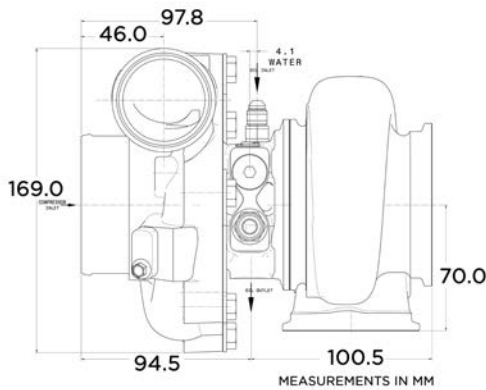

INTERNALLY WASTEGATED



REVERSE ROTATION

FEATURES:

- ◆ G-SERIES COMPRESSOR AERODYNAMICS FOR MAXIMUM HP
- ◆ G-SERIES TURBINE WHEEL AERO WITH IMPROVED EFFICIENCY
- ◆ STANDARD AND REVERSE ROTATION CONFIGURATIONS
- ◆ TURBINE WHEEL CONSTRUCTED OF MAR-M ALLOY RATED UP TO 1050°C
- ◆ FULLY MACHINED SPEED SENSOR AND PRESSURE PORTS
- ◆ OIL RESTRICTOR AND WATER FITTINGS INCLUDED

COMPRESSOR MAP

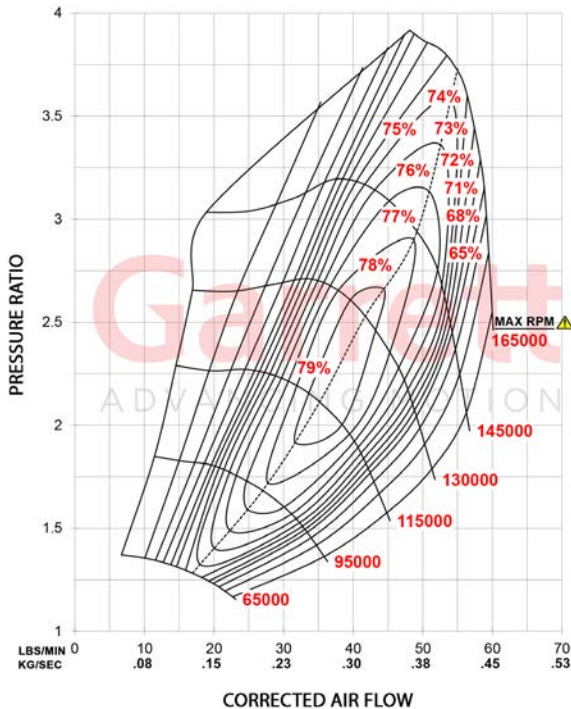

EXHAUST FLOW CHART

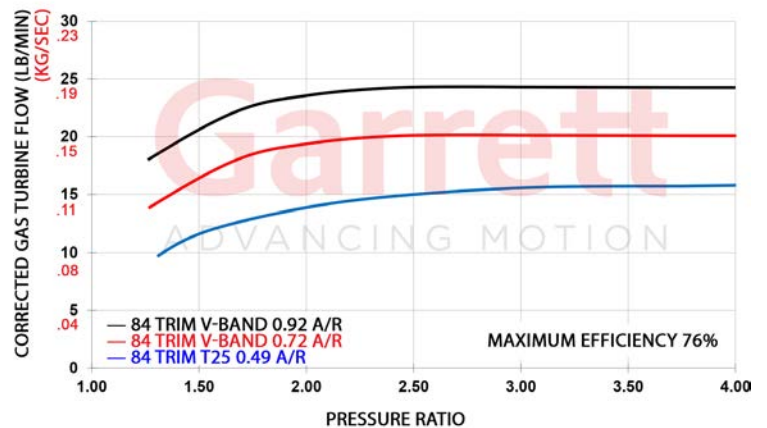

G25-660		Compressor				Turbine		
		Inducer	Exducer	Trim	A/R	Inducer	Exducer	Trim
HP: 350-660	Disp: 1.4L-3.0L	54mm	67mm	65	0.70	54mm	49mm	84
Turbo: Standard Rotation		PN		A/R	Inlet	Outlet	Wastegate	Divided
Assembled and calibrated with 0.5 bar actuator		877895-5002S		0.49	T25	V-Band	Internal	N
		877895-5005S		0.72	V-Band	V-Band	Internal	N
		877895-5006S		0.92	V-Band	V-Band	Internal	N
Turbo: Reverse Rotation		PN		A/R	Inlet	Outlet	Wastegate	Divided
See note above		877895-5009S		0.72	V-Band	V-Band	Internal	N
		877895-5010S		0.92	V-Band	V-Band	Internal	N
Turbine Kits Standard Rotation		PN		A/R	Inlet	Outlet	Wastegate	Divided
Internal Wastegate		740902-0076		0.72	V-Band	V-Band	Internal	N
		740902-0077		0.92	V-Band	V-Band	Internal	N
		740902-0080		0.49	T25	V-Band	Internal	N
Turbine Kits Reverse Rotation		PN		A/R	Inlet	Outlet	Wastegate	Divided
Internal Wastegate		740902-0078		0.72	V-Band	V-Band	Internal	N
		740902-0079		0.92	V-Band	V-Band	Internal	N
Supercore		PN						
Standard Rotation		858161-5003S						
Reverse Rotation		871388-5002S						
Turbine Kits Standard Rotation		PN		A/R	Inlet	Outlet	Wastegate	Divided
Free Float		740902-0069		0.72	V-Band	V-Band	External	N
		740902-0068		0.92	V-Band	V-Band	External	N
Turbine Kits Reverse Rotation		PN		A/R	Inlet	Outlet	Wastegate	Divided
Free Float		740902-0073		0.72	V-Band	V-Band	External	N
		740902-0074		0.92	V-Band	V-Band	External	N

Garrett G30-660

Horsepower: 350 - 660
Displacement: 2.0L - 3.5L

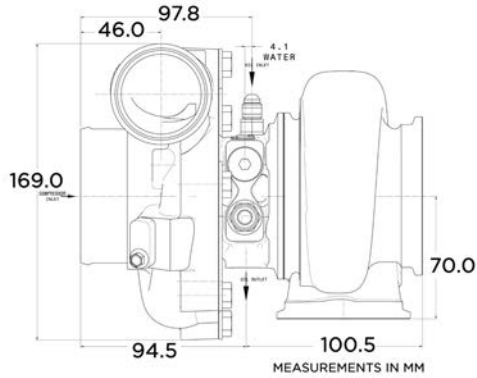

COMPRESSOR MAP

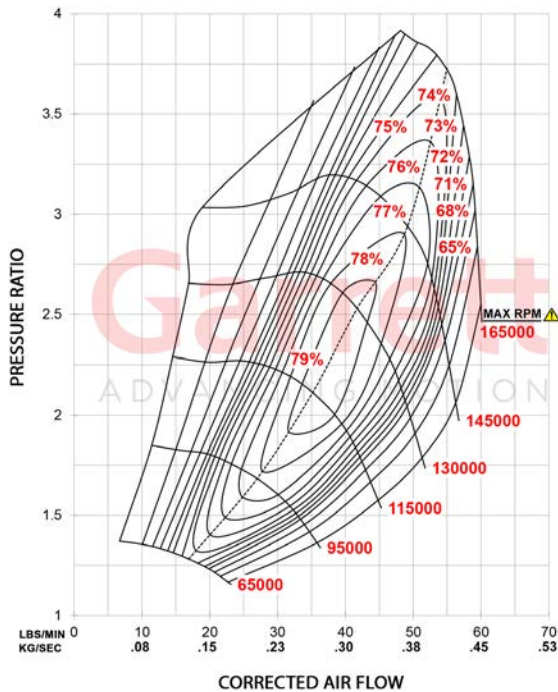

REVERSE ROTATION

FEATURES:

- ◆ G-SERIES COMPRESSOR AERODYNAMICS FOR MAXIMUM HP
- ◆ G-SERIES TURBINE WHEEL AERO WITH IMPROVED EFFICIENCY
- ◆ STANDARD AND REVERSE ROTATION CONFIGURATIONS
- ◆ TURBINE WHEEL CONSTRUCTED OF MAR-M ALLOY RATED UP TO 1050°C
- ◆ FULLY MACHINED SPEED SENSOR AND PRESSURE PORTS
- ◆ OIL RESTRICTOR AND WATER FITTINGS INCLUDED

EXHAUST FLOW CHART

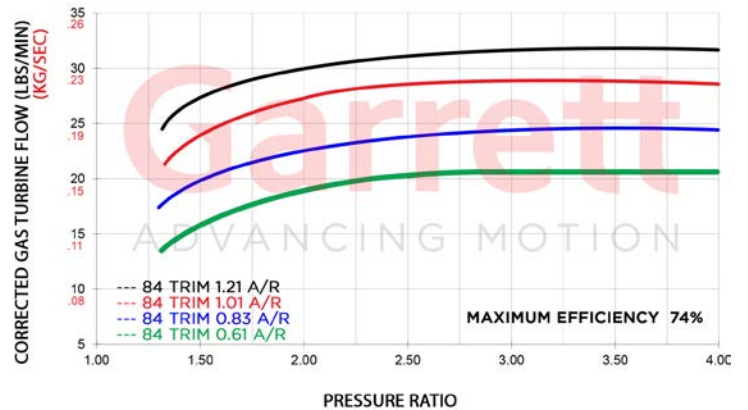

G30-660	Compressor				Turbine				
	HP: 350-660	Disp: 2.0L-3.5L	Inducer 54mm	Exducer 67mm	Trim 65	A/R 0.70	Inducer 60mm	Exducer 55mm	Trim 84
Turbo: Standard Rotation		PN		A/R	Inlet	Outlet	Wastegate	Divided	
Assembled and calibrated with 0.5 bar actuator		880704-5002S		0.83	V-Band	V-Band	Internal	N	
		880704-5003S		1.01	V-Band	V-Band	Internal	N	
Turbine Kits Standard Rotation		PN		A/R	Inlet	Outlet	Wastegate	Divided	
Internal Wastegate		740902-0094		0.83	V-Band	V-Band	Internal	N	
		740902-0095		1.01	V-Band	V-Band	Internal	N	
Supercore		PN							
Standard Rotation		880693-5001S							
Reverse Rotation		880694-5001S							
Turbine Kits Standard Rotation		PN		A/R	Inlet	Outlet	Wastegate	Divided	
Free Float		740902-0092		1.06	T4	V-Band	External	Y	
		740902-0090		0.83	T3	V-Band	External	N	
		740902-0091		1.01	T3	V-Band	External	N	
		740902-0086		0.61	V-Band	V-Band	External	N	
		740902-0087		0.83	V-Band	V-Band	External	N	
		740902-0088		1.01	V-Band	V-Band	External	N	
		740902-0089		1.21	V-Band	V-Band	External	N	
Turbine Kits Reverse Rotation		PN		A/R	Inlet	Outlet	Wastegate	Divided	
Free Float		740902-0100		0.83	T3	V-Band	External	N	
		740902-0101		1.01	T3	V-Band	External	N	
		740902-0096		0.61	V-Band	V-Band	External	N	
		740902-0097		0.83	V-Band	V-Band	External	N	
		740902-0098		1.01	V-Band	V-Band	External	N	
		740902-0099		1.21	V-Band	V-Band	External	N	

Garrett G30-770

Horsepower: 475 - 770
Displacement: 2.0L - 3.5L

Garrett
ADVANCING MOTION

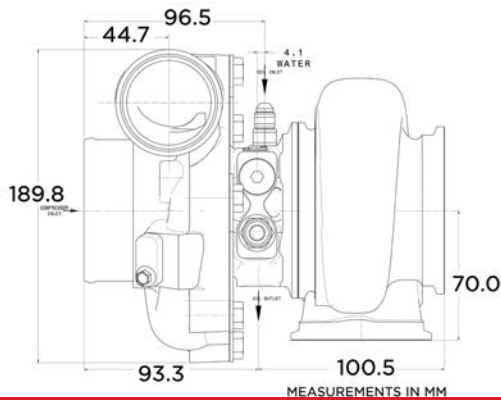

COMPRESSOR MAP

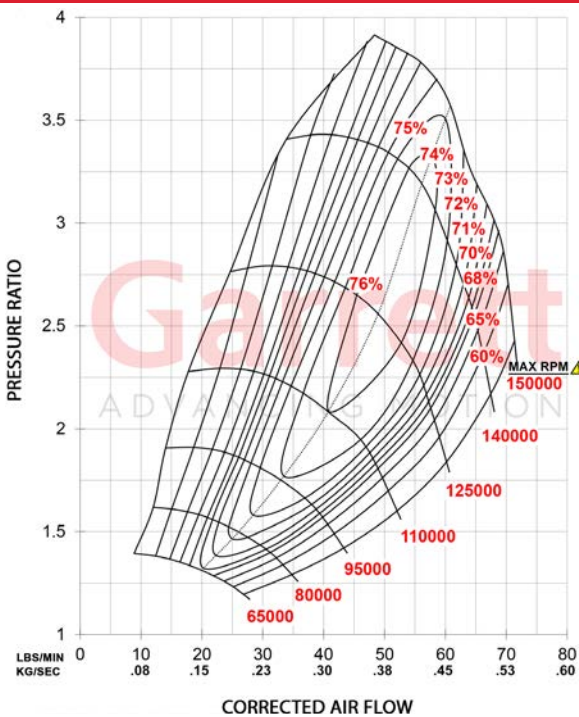

REVERSE ROTATION

FEATURES:

- ◆ G-SERIES COMPRESSOR AERODYNAMICS FOR MAXIMUM HP
- ◆ G-SERIES TURBINE WHEEL AERO WITH IMPROVED EFFICIENCY
- ◆ STANDARD AND REVERSE ROTATION CONFIGURATIONS
- ◆ TURBINE WHEEL CONSTRUCTED OF MAR-M ALLOY RATED UP TO 1050°C
- ◆ FULLY MACHINED SPEED SENSOR AND PRESSURE PORTS
- ◆ OIL RESTRICTOR AND WATER FITTINGS INCLUDED

EXHAUST FLOW CHART

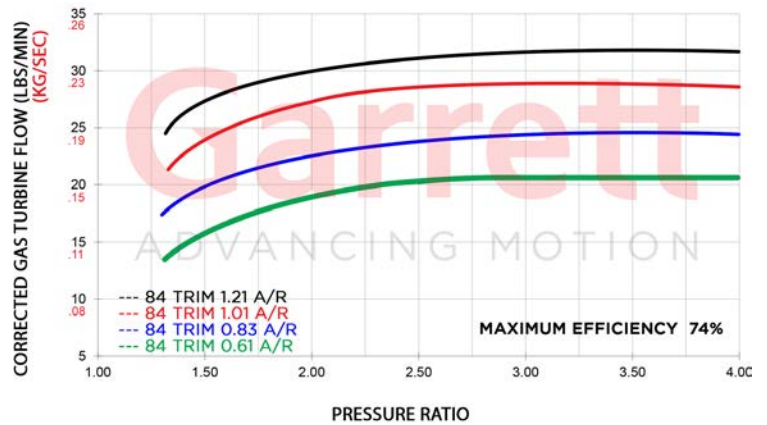

G30-770 HP: 475-770 Disp: 2.0L-3.5L	Compressor				Turbine		
	Inducer 58mm	Exducer 71mm	Trim 65	A/R 0.72	Inducer 60mm	Exducer 55mm	Trim 84
Turbo: Standard Rotation	PN		A/R	Inlet	Outlet	Wastegate	Divided
Assembled and calibrated with 0.5 bar actuator	880704-5005S		0.83	V-Band	V-Band	Internal	N
	880704-5006S		1.01	V-Band	V-Band	Internal	N
Turbine Kits Standard Rotation	PN		A/R	Inlet	Outlet	Wastegate	Divided
Internal Wastegate	740902-0094		0.83	V-Band	V-Band	Internal	N
	740902-0095		1.01	V-Band	V-Band	Internal	N
Supercore	PN						
Standard Rotation	880693-5002S						
Reverse Rotation	880694-5002S						
Turbine Kits Standard Rotation	PN		A/R	Inlet	Outlet	Wastegate	Divided
Free Float	740902-0092		1.06	T4	V-Band	External	Y
	740902-0090		0.83	T3	V-Band	External	N
	740902-0091		1.01	T3	V-Band	External	N
	740902-0086		0.61	V-Band	V-Band	External	N
	740902-0087		0.83	V-Band	V-Band	External	N
	740902-0088		1.01	V-Band	V-Band	External	N
	740902-0089		1.21	V-Band	V-Band	External	N
Turbine Kits Reverse Rotation	PN		A/R	Inlet	Outlet	Wastegate	Divided
Free Float	740902-0100		0.83	T3	V-Band	External	N
	740902-0101		1.01	T3	V-Band	External	N
	740902-0096		0.61	V-Band	V-Band	External	N
	740902-0097		0.83	V-Band	V-Band	External	N
	740902-0098		1.01	V-Band	V-Band	External	N
	740902-0099		1.21	V-Band	V-Band	External	N

Garrett G30-900

Horsepower: 550 - 900
Displacement: 2.0L - 3.5L

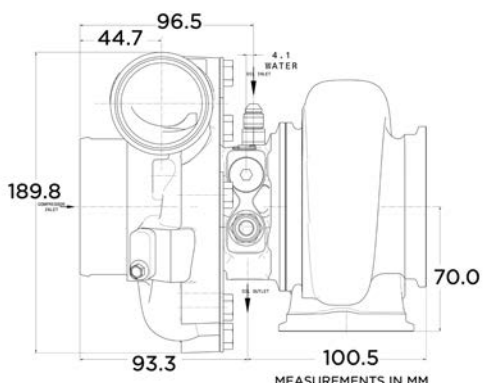

COMPRESSOR MAP

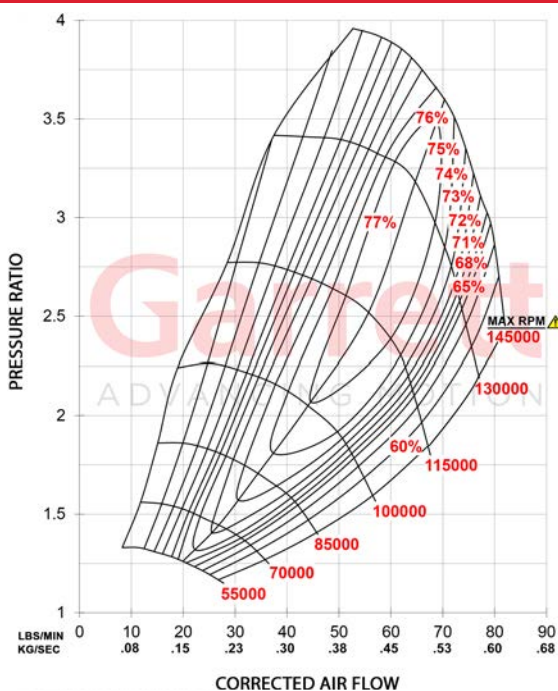

REVERSE ROTATION

FEATURES:

- ◆ G-SERIES COMPRESSOR AERODYNAMICS FOR MAXIMUM HP
- ◆ G-SERIES TURBINE WHEEL AERO WITH IMPROVED EFFICIENCY
- ◆ STANDARD AND REVERSE ROTATION CONFIGURATIONS
- ◆ TURBINE WHEEL CONSTRUCTED OF MAR-M ALLOY RATED UP TO 1050°C
- ◆ FULLY MACHINED SPEED SENSOR AND PRESSURE PORTS
- ◆ OIL RESTRICTOR AND WATER FITTINGS INCLUDED

EXHAUST FLOW CHART

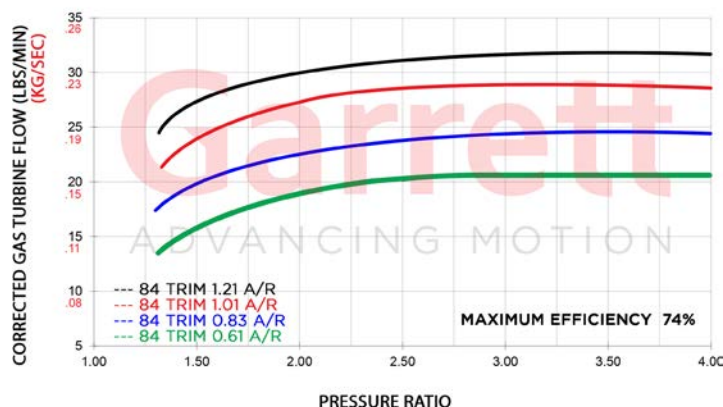

G30-900		Compressor				Turbine		
		Inducer	Exducer	Trim	A/R	Inducer	Exducer	Trim
HP: 550-900	Disp: 2.0L-3.5L	62mm	76mm	65	0.72	60mm	55mm	84
Turbo: Standard Rotation		PN		A/R	Inlet	Outlet	Wastegate	Divided
Assembled and calibrated with 0.5 bar actuator		880704-5008S		0.83	V-Band	V-Band	Internal	N
		880704-5009S		1.01	V-Band	V-Band	Internal	N
Turbine Kits Standard Rotation		PN		A/R	Inlet	Outlet	Wastegate	Divided
Internal Wastegate		740902-0094		0.83	V-Band	V-Band	Internal	N
		740902-0095		1.01	V-Band	V-Band	Internal	N
Supercore		PN						
Supercore: Standard Rotation		880693-5003S						
Supercore: Reverse Rotation		880694-5003S						
Turbine Kits Standard Rotation		PN		A/R	Inlet	Outlet	Wastegate	Divided
Free Float		740902-0092		1.06	T4	V-Band	External	Y
		740902-0090		0.83	T3	V-Band	External	N
		740902-0091		1.01	T3	V-Band	External	N
		740902-0086		0.61	V-Band	V-Band	External	N
		740902-0087		0.83	V-Band	V-Band	External	N
		740902-0088		1.01	V-Band	V-Band	External	N
		740902-0089		1.21	V-Band	V-Band	External	N
Turbine Kits Reverse Rotation		PN		A/R	Inlet	Outlet	Wastegate	Divided
Free Float		740902-0100		0.83	T3	V-Band	External	N
		740902-0101		1.01	T3	V-Band	External	N
		740902-0096		0.61	V-Band	V-Band	External	N
		740902-0097		0.83	V-Band	V-Band	External	N
		740902-0098		1.01	V-Band	V-Band	External	N
		740902-0099		1.21	V-Band	V-Band	External	N

Garrett G35-900

Horsepower: 550 - 900
Displacement: 2.0L - 5.5L

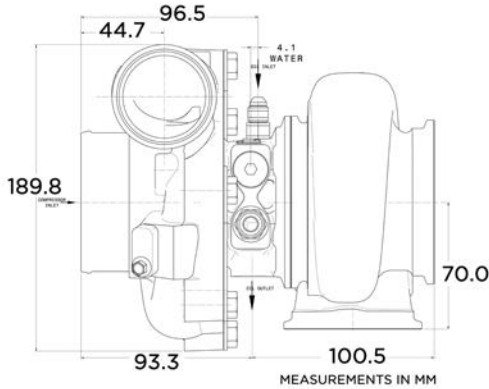

REVERSE ROTATION

COMPRESSOR MAP

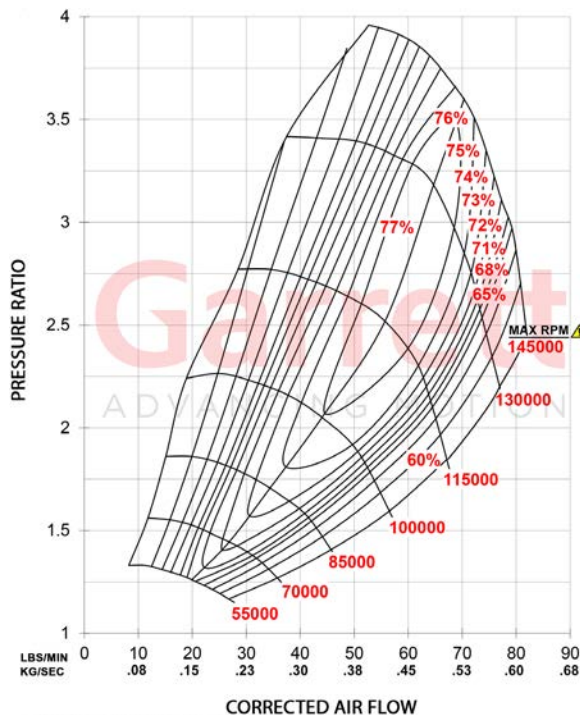

FEATURES:

- ◆ G-SERIES COMPRESSOR AERODYNAMICS FOR MAXIMUM HP
- ◆ G-SERIES TURBINE WHEEL AERO WITH IMPROVED EFFICIENCY
- ◆ STANDARD AND REVERSE ROTATION CONFIGURATIONS
- ◆ TURBINE WHEEL CONSTRUCTED OF MAR-M ALLOY RATED UP TO 1050°C
- ◆ FULLY MACHINED SPEED SENSOR AND PRESSURE PORTS
- ◆ OIL RESTRICTOR AND WATER FITTINGS INCLUDED

EXHAUST FLOW CHART

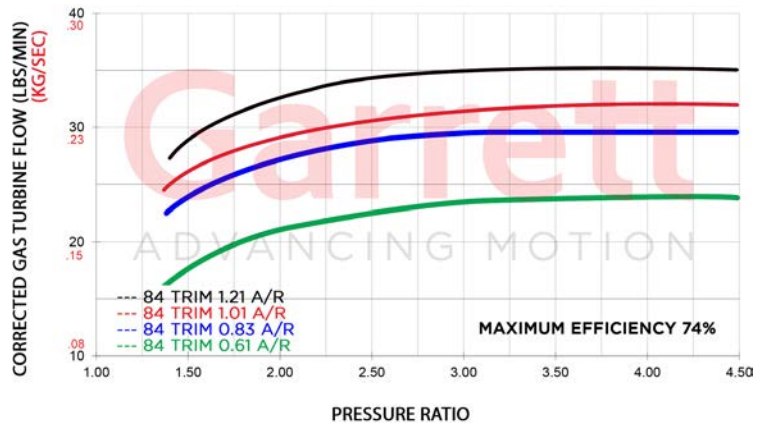

G35-900	Compressor				Turbine				
	Inducer	Exducer	Trim	A/R	Inducer	Exducer	Trim		
HP: 550-900 Disp: 2.0L-5.5L	62mm	76mm	65	0.72	68mm	62mm	84		
Turbo: Standard Rotation	PN				Outlet	Wastegate	Divided		
Assembled and calibrated with 0.5 bar actuator	880707-5002S		0.83	V-Band	V-Band	Internal	N		
	880707-5003S		1.01	V-Band	V-Band	Internal	N		
Turbine Kits Standard Rotation	PN				Outlet	Wastegate	Divided		
Internal Wastegate	740902-0110		0.83	V-Band	V-Band	Internal	N		
	740902-0111		1.01	V-Band	V-Band	Internal	N		
Supercore	PN								
Supercore: Standard Rotation	880695-5001S								
Supercore: Reverse Rotation	880696-5001S								
Turbine Kits Standard Rotation	PN				A/R	Inlet	Outlet	Wastegate	Divided
Free Float	740902-0108		1.06	T4	V-Band	External	Y		
	740902-0106		0.83	T3	V-Band	External	N		
	740902-0107		1.01	T3	V-Band	External	N		
	740902-0102		0.61	V-Band	V-Band	External	N		
	740902-0103		0.83	V-Band	V-Band	External	N		
	740902-0104		1.01	V-Band	V-Band	External	N		
	740902-0105		1.21	V-Band	V-Band	External	N		
Turbine Kits Reverse Rotation	PN				A/R	Inlet	Outlet	Wastegate	Divided
Free Float	740902-0116		0.83	T3	V-Band	External	N		
	740902-0117		1.01	T3	V-Band	External	N		
	740902-0112		0.61	V-Band	V-Band	External	N		
	740902-0113		0.83	V-Band	V-Band	External	N		
	740902-0114		1.01	V-Band	V-Band	External	N		
	740902-0115		1.21	V-Band	V-Band	External	N		

Garrett G35-1050

Horsepower: 700 - 1050
Displacement: 2.0L - 5.5L

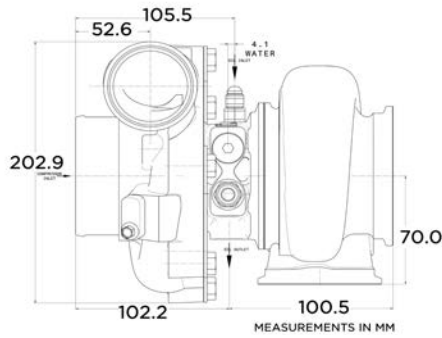

REVERSE ROTATION

COMPRESSOR MAP

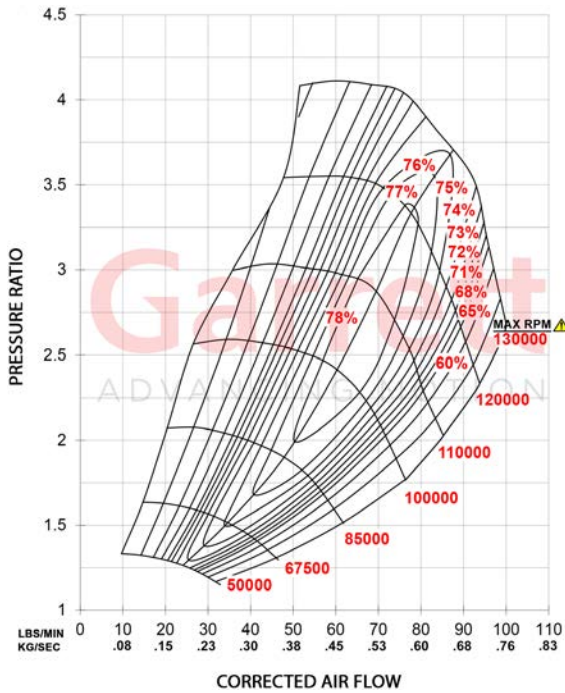

FEATURES:

- ◆ G-SERIES COMPRESSOR AERODYNAMICS FOR MAXIMUM HP
- ◆ G-SERIES TURBINE WHEEL AERO WITH IMPROVED EFFICIENCY
- ◆ STANDARD AND REVERSE ROTATION CONFIGURATIONS
- ◆ TURBINE WHEEL CONSTRUCTED OF MAR-M ALLOY RATED UP TO 1050°C
- ◆ FULLY MACHINED SPEED SENSOR AND PRESSURE PORTS
- ◆ OIL RESTRICTOR AND WATER FITTINGS INCLUDED

EXHAUST FLOW CHART

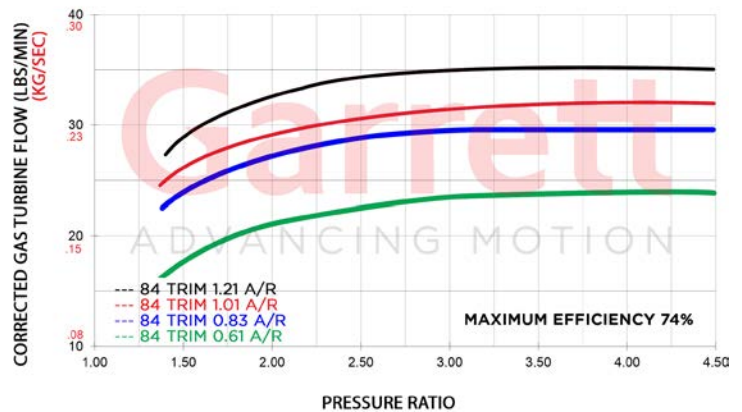

G35-1050	Compressor				Turbine		
	Inducer	Exducer	Trim	A/R	Inducer	Exducer	Trim
HP: 700-1050 Disp: 2.0L-5.5L	68mm	84mm	65	0.75	68mm	62mm	84
Standard Turbo: G35-1050	PN		A/R	Inlet	Outlet	Wastgate	Divided
Assembled and calibrated with 0.5 bar actuator	880707-5005S		0.83	V-Band	V-Band	Internal	N
	880707-5006S		1.01	V-Band	V-Band	Internal	N
Turbine Kits Standard Rotation	PN		A/R	Inlet	Outlet	Wastgate	Divided
Internal Wastgate	740902-0110		0.83	V-Band	V-Band	Internal	N
	740902-0111		1.01	V-Band	V-Band	Internal	N
Supercore	PN						
Supercore: Standard Rotation	880695-5002S						
Supercore: Reverse Rotation	880696-5002S						
Turbine Kits Standard Rotation	PN		A/R	Inlet	Outlet	Wastgate	Divided
Free Float	740902-0108		1.06	T4	V-Band	External	Y
	740902-0106		0.83	T3	V-Band	External	N
	740902-0107		1.01	T3	V-Band	External	N
	740902-0102		0.61	V-Band	V-Band	External	N
	740902-0103		0.83	V-Band	V-Band	External	N
	740902-0104		1.01	V-Band	V-Band	External	N
	740902-0105		1.21	V-Band	V-Band	External	N
Turbine Kits Reverse Rotation	PN		A/R	Inlet	Outlet	Wastgate	Divided
Free Float	740902-0116		0.83	T3	V-Band	External	N
	740902-0117		1.01	T3	V-Band	External	N
	740902-0112		0.61	V-Band	V-Band	External	N
	740902-0113		0.83	V-Band	V-Band	External	N
	740902-0114		1.01	V-Band	V-Band	External	N
	740902-0115		1.21	V-Band	V-Band	External	N

Garrett G40-900

Horsepower: 500 - 900
Displacement: 2.0L - 6.0L

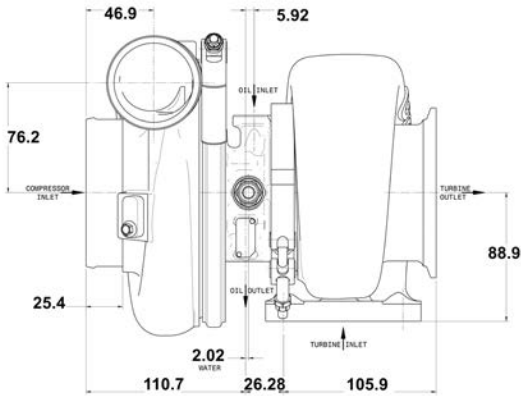

COMPRESSOR MAP

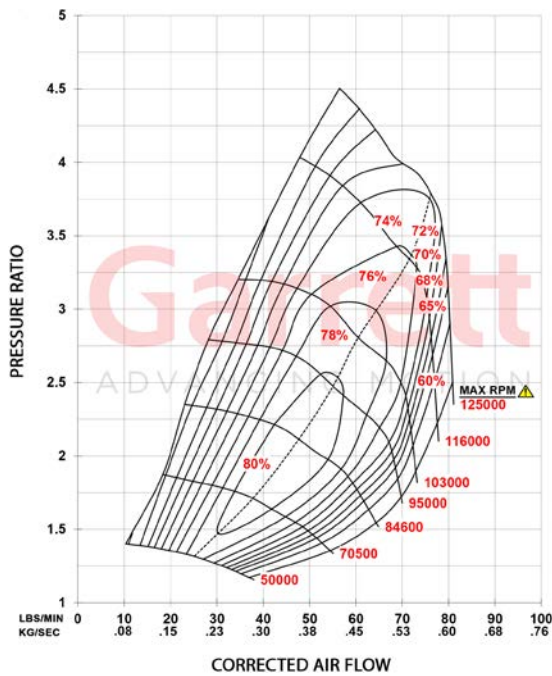

FEATURES:

- ◆ UP TO 32% MORE COMPRESSOR FLOW (COMPARED TO GTX4088R)
- ◆ CERAMIC DUAL BALL BEARING WITH STEEL CAGES
- ◆ UP TO 16% MORE TURBINE FLOW (COMPARED TO GTX4088R)
- ◆ 77MM INCONEL TURBINE WHEEL FLOWS UP TO 43 LBS/MIN
- ◆ LIGHTWEIGHT ALUMINUM BACKPLATE
- ◆ FULLY MACHINED SPEED SENSOR AND PRESSURE PORTS
- ◆ WATER FITTINGS INCLUDED WITH SUPERCORE
- ◆ STAINLESS STEEL V-BAND AND T4 TWIN SCROLL TURBINE HOUSINGS
- ◆ T4 TURBINE HOUSING OUTLET V-BAND DIMENSION (117.4MM | 4.622" OD) IS EQUAL TO EXISTING GTX42, GTX45 AND G42 MODELS

EXHAUST FLOW CHART

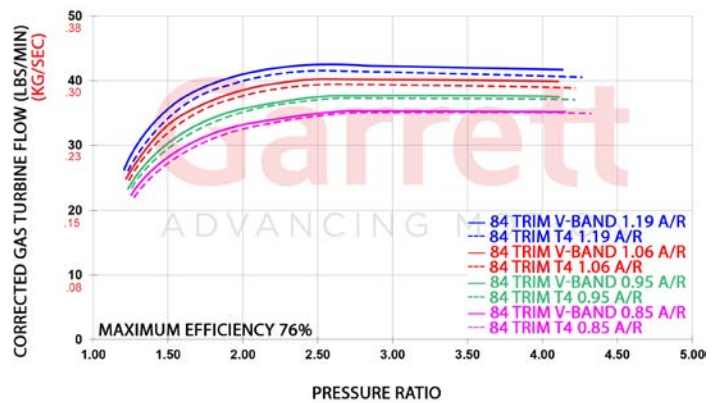

G40-900 HP: 500-900 Disp: 2.0L-6.0L	Compressor				Turbine				
	Inducer 62mm	Exducer 88mm	Trim 51	A/R 0.80	Inducer 77mm	Exducer 70mm	Trim 84		
Supercore	PN								
Standard Rotation	860777-5003S								
Turbine Kits: G40	PN				A/R	Inlet	Outlet	Wastegate	Divided
Free Float	757707-0027			0.85	V-Band	V-Band	External	N	
	757707-0028			0.95	V-Band	V-Band	External	N	
	757707-0029			1.06	V-Band	V-Band	External	N	
	757707-0030			1.19	V-Band	V-Band	External	N	
	757707-0032			0.85	T4	V-Band	External	Y	
	757707-0033			0.95	T4	V-Band	External	Y	
	757707-0034			1.06	T4	V-Band	External	Y	
	757707-0035			1.19	T4	V-Band	External	Y	

Garrett G40-1150

Horsepower: 500 - 1150
Displacement: 2.0L - 6.0L

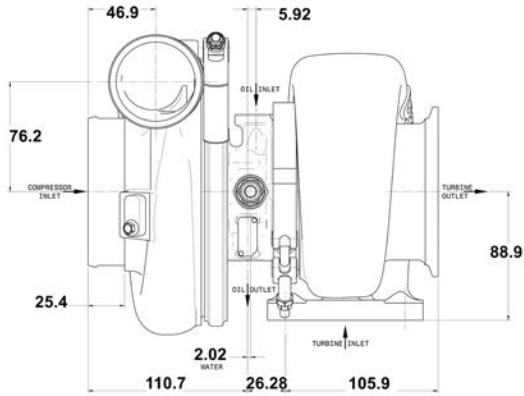

COMPRESSOR MAP

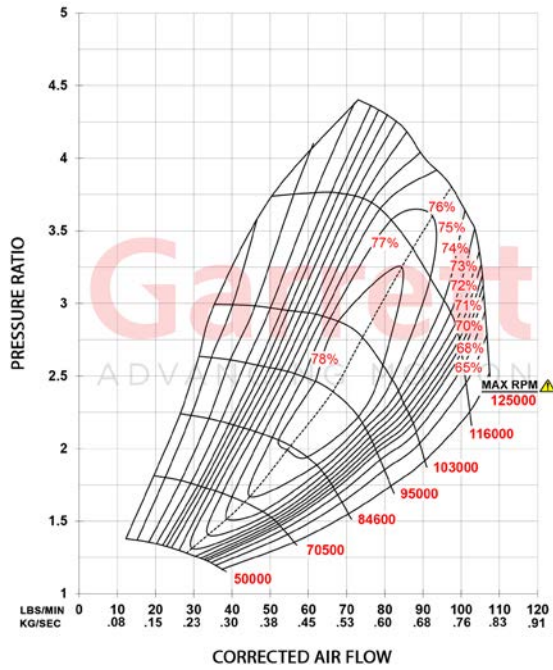

FEATURES:

- ◆ UP TO 32% MORE COMPRESSOR FLOW (COMPARED TO GTX4088R)
- ◆ CERAMIC DUAL BALL BEARING WITH STEEL CAGES
- ◆ UP TO 16% MORE TURBINE FLOW (COMPARED TO GTX4088R)
- ◆ 77MM INCONEL TURBINE WHEEL FLOWS UP TO 43 LBS/MIN
- ◆ LIGHTWEIGHT ALUMINUM BACKPLATE
- ◆ FULLY MACHINED SPEED SENSOR AND PRESSURE PORTS
- ◆ WATER FITTINGS INCLUDED WITH SUPERCORE
- ◆ STAINLESS STEEL V-BAND AND T4 TWIN SCROLL TURBINE HOUSINGS
- ◆ T4 TURBINE HOUSING OUTLET V-BAND DIMENSION (117.4MM | 4.622" OD) IS EQUAL TO EXISTING GTX42, GTX45 AND G42 MODELS

EXHAUST FLOW CHART

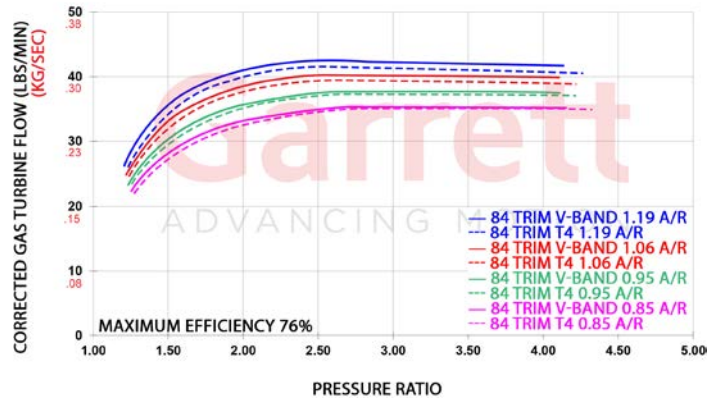

G40-1150 HP: 500-1150 Disp: 2.0L-6.0L	Compressor				Turbine				
	Inducer 71mm	Exducer 88mm	Trim 65	A/R 0.80	Inducer 77mm	Exducer 70mm	Trim 84		
Supercore	PN								
Standard Rotation	860777-5002S								
Turbine Kits: G40	PN				A/R	Inlet	Outlet	Wastegate	Divided
Free Float	757707-0027		0.85	V-Band	V-Band	External	N		
	757707-0028		0.95	V-Band	V-Band	External	N		
	757707-0029		1.06	V-Band	V-Band	External	N		
	757707-0030		1.19	V-Band	V-Band	External	N		
	757707-0032		0.85	T4	V-Band	External	Y		
	757707-0033		0.95	T4	V-Band	External	Y		
	757707-0034		1.06	T4	V-Band	External	Y		
	757707-0035		1.19	T4	V-Band	External	Y		

Garrett G42-1200 Compact

Horsepower: 475 - 1200
Displacement: 2.0L - 7.0L

Garrett
ADVANCING MOTION

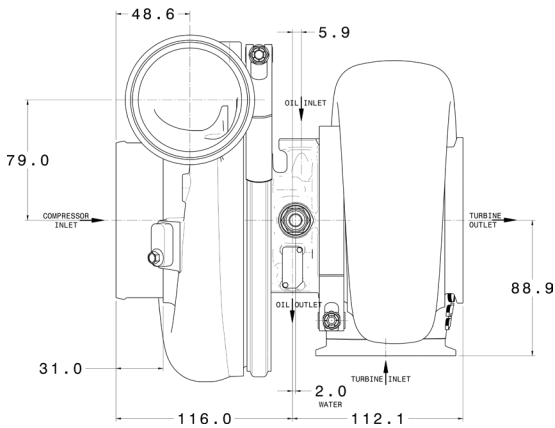

COMPRESSOR MAP

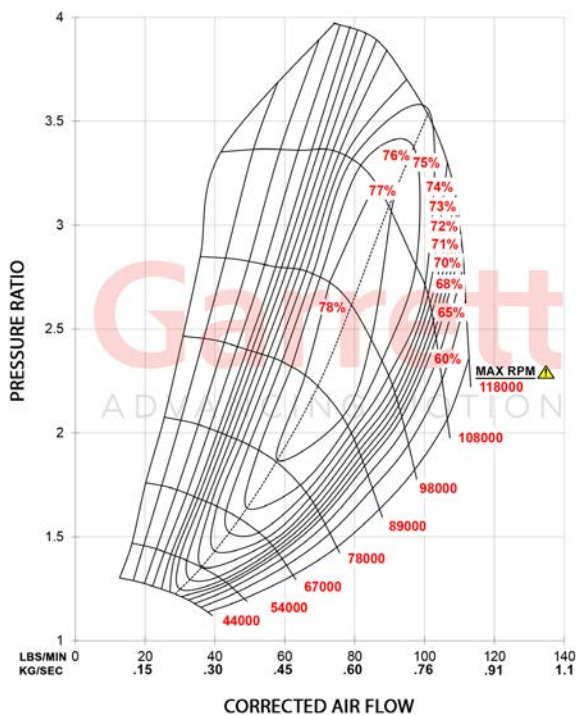

FEATURES:

- ◆ GARRETT G-SERIES COMPRESSOR AERODYNAMICS FOR MAXIMUM HP
- ◆ FULLY MACHINED SPEED SENSOR AND PRESSURE PORTS
- ◆ NEW TURBINE WHEEL AERO FOR INCREASED EFFICIENCY AND FLOW
- ◆ STAINLESS STEEL V-BAND AND T4 TWIN SCROLL TURBINE HOUSINGS
- ◆ WATER FITTINGS INCLUDED

EXHAUST FLOW CHART

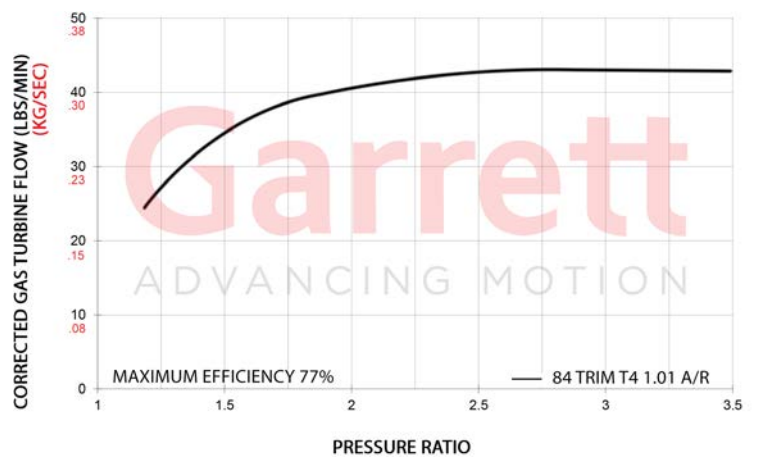

G42-1200 Compact	Compressor				A/R	Turbine			
	HP: 475-1200	Disp: 2.0L-7.0L	Inducer	Exducer		Trim	Inducer	Exducer	Trim
Supercore			73mm	91mm	65	82mm	75mm	84	
Compact Comp Housing			PN 860778-5002S						
Turbine Kits: G42			PN		A/R	Inlet	Outlet	Wastegate	Divided
Free Float			757707-0011		1.01	V-Band	V-Band	External	N
			757707-0012		1.15	V-Band	V-Band	External	N
			757707-0013		1.28	V-Band	V-Band	External	N
			757707-0014		1.01	T4	V-Band	External	Y
			757707-0015		1.15	T4	V-Band	External	Y
			757707-0016		1.28	T4	V-Band	External	Y

Garrett G42-1200

Horsepower: 475 - 1200
Displacement: 2.0L - 7.0L

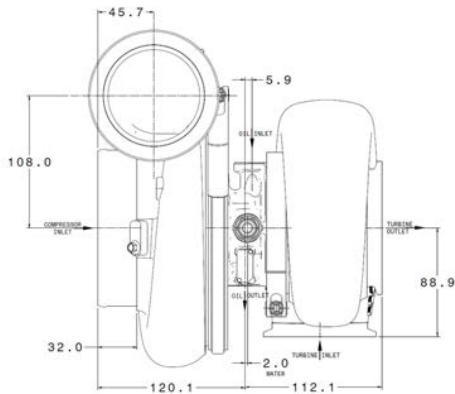

COMPRESSOR MAP

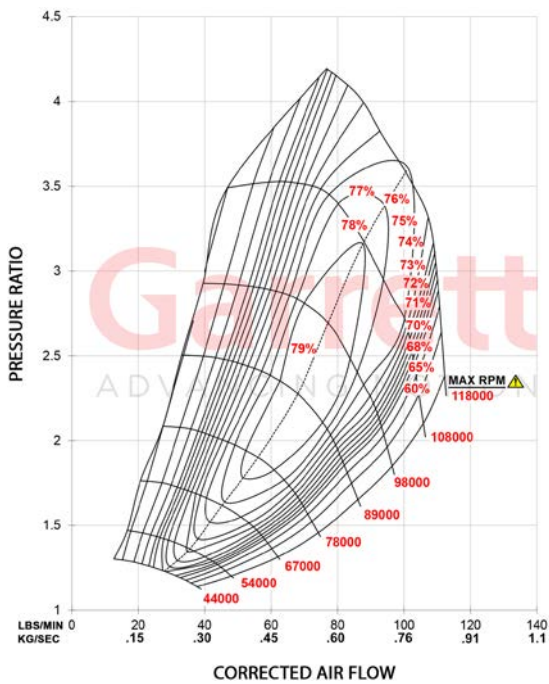

FEATURES:

- ◆ GARRETT G-SERIES COMPRESSOR AERODYNAMICS FOR MAXIMUM HP
- ◆ FULLY MACHINED SPEED SENSOR AND PRESSURE PORTS
- ◆ NEW TURBINE WHEEL AERO FOR INCREASED EFFICIENCY AND FLOW
- ◆ STAINLESS STEEL V-BAND AND T4 TWIN SCROLL TURBINE HOUSINGS
- ◆ WATER FITTINGS INCLUDED

EXHAUST FLOW CHART

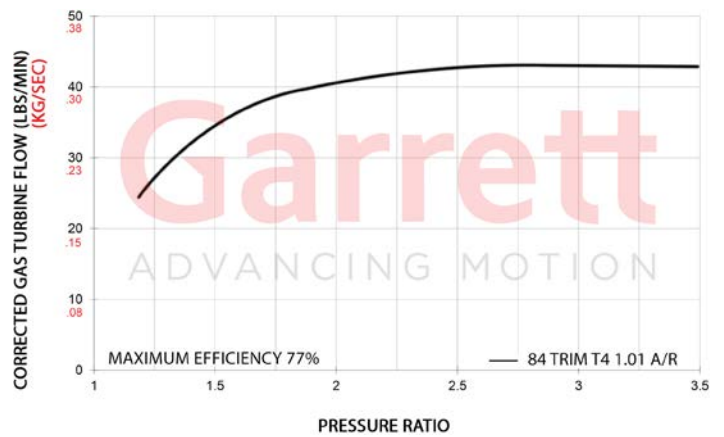

G42-1200		Compressor				Turbine				
HP: 475-1200	Disp: 2.0L-7.0L	Inducer	Exducer	Trim	A/R	Inducer	Exducer	Trim		
Supercore		73mm	91mm	65	0.85	82mm	75mm	84		
Full-Size Comp Housing		860778-5004S								
Turbine Kits: G42		PN				A/R	Inlet	Outlet	Wastegate	Divided
Free Float		757707-0011		1.01	V-Band	V-Band	External	N		
		757707-0012		1.15	V-Band	V-Band	External	N		
		757707-0013		1.28	V-Band	V-Band	External	N		
		757707-0014		1.01	T4	V-Band	External	Y		
		757707-0015		1.15	T4	V-Band	External	Y		
		757707-0016		1.28	T4	V-Band	External	Y		

Garrett G42-1450

Horsepower: 525 - 1450
Displacement: 2.0L - 8.0L

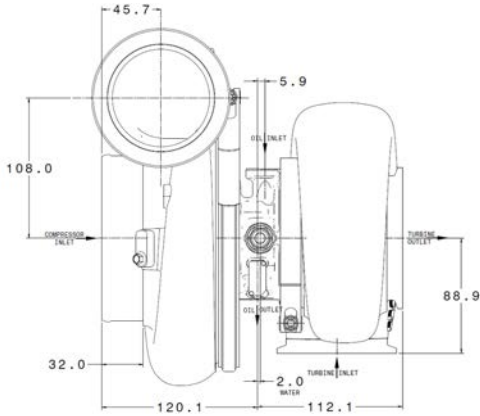

COMPRESSOR MAP

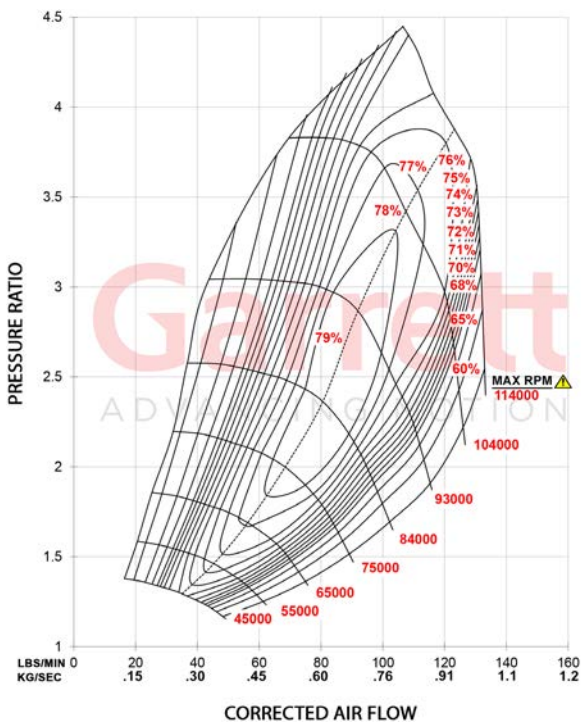

FEATURES:

- ◆ GARRETT G-SERIES COMPRESSOR AERODYNAMICS FOR MAXIMUM HP
- ◆ FULLY MACHINED SPEED SENSOR AND PRESSURE PORTS
- ◆ NEW TURBINE WHEEL AERO FOR INCREASED EFFICIENCY AND FLOW
- ◆ STAINLESS STEEL V-BAND AND T4 TWIN SCROLL TURBINE HOUSINGS
- ◆ WATER FITTINGS INCLUDED

EXHAUST FLOW CHART

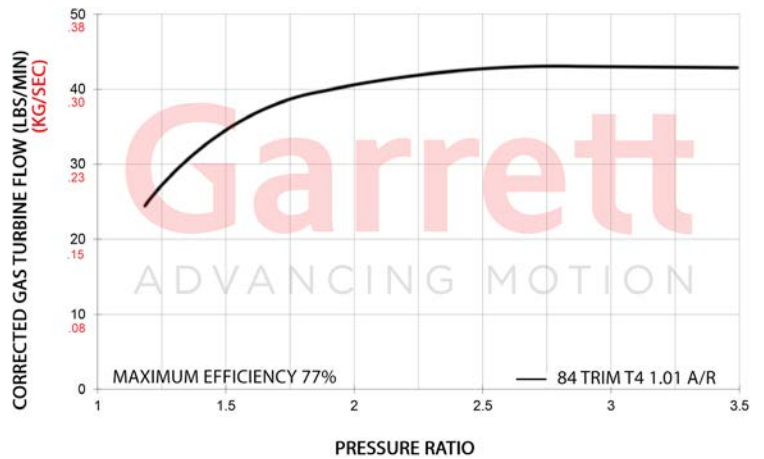

G42-1450	Compressor				Turbine				
	HP: 525-1450	Disp: 2.0L-8.0L	Inducer	Exducer	Trim	A/R	Inducer	Exducer	Trim
Supercore	PN								
Standard Rotation	860778-5006S								
Turbine Kits: G42			PN	A/R	Inlet	Outlet	Wastegate	Divided	
Free Float			757707-0011	1.01	V-Band	V-Band	External	N	
			757707-0012	1.15	V-Band	V-Band	External	N	
			757707-0013	1.28	V-Band	V-Band	External	N	
			757707-0014	1.01	T4	V-Band	External	Y	
			757707-0015	1.15	T4	V-Band	External	Y	
			757707-0016	1.28	T4	V-Band	External	Y	

Garrett G45-1125

Horsepower: 600 - 1125
Displacement: 2.0L - 8.0L

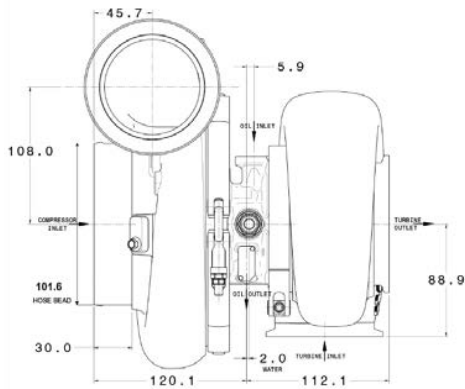

COMPRESSOR MAP

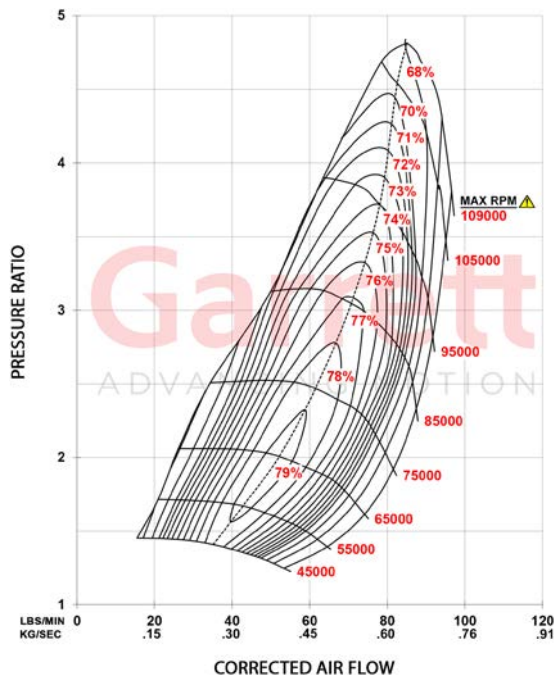

FEATURES:

- ◆ COMPRESSOR AERO INCREASES FLOW UP TO 10% (COMPARED TO GTX4502R 67MM)
- ◆ 67MM COMPRESSOR INDUCER | 102MM COMPRESSOR EXDUCER
- ◆ 10MM CERAMIC DUAL BALL BEARING WITH STEEL CAGES
- ◆ G-SERIES TURBINE AERO INCREASES FLOW 14% (COMPARED TO GTX45R)
- ◆ 89MM INCONEL TURBINE WHEEL INDUCER FLOWS UP TO 56 LBS/MIN
- ◆ LIGHTWEIGHT ALUMINUM BACKPLATE
- ◆ STAINLESS STEEL V-BAND AND T4 TWIN SCROLL TURBINE HOUSINGS

EXHAUST FLOW CHART

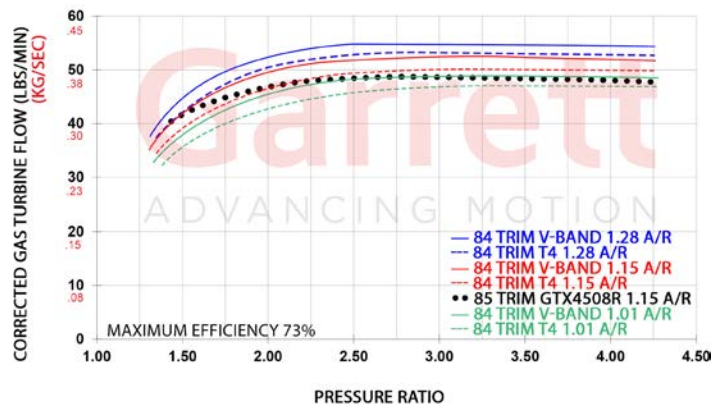

G45-1125	Compressor				Turbine				
	HP: 600-1125	Disp: 2.0L-8.0L	Inducer 67mm	Exducer 102mm	Trim 44	A/R 0.85	Inducer 89mm	Exducer 82mm	Trim 84
Supercore	PN								
Standard Rotation	888169-5003S								
Turbine Kits: G45	PN								
Free Float			757707-0019		1.01	V-Band	V-Band	External	N
			757707-0020		1.15	V-Band	V-Band	External	N
			757707-0021		1.28	V-Band	V-Band	External	N
			757707-0022		1.44	V-Band	V-Band	External	N
			757707-0023		1.01	T4	V-Band	External	Y
			757707-0024		1.15	T4	V-Band	External	Y
			757707-0025		1.28	T4	V-Band	External	Y
			757707-0026		1.44	T4	V-Band	External	Y

Garrett G45-1350

Horsepower: 650 - 1350
Displacement: 2.0L - 8.0L

Garrett
ADVANCING MOTION

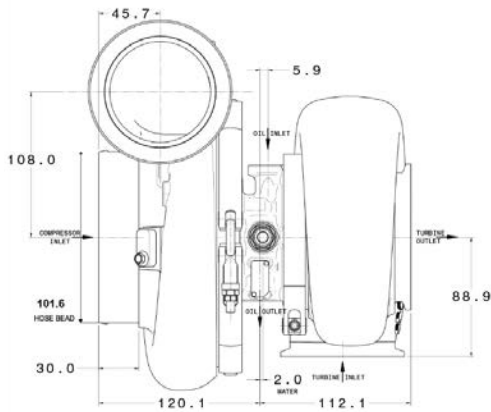

COMPRESSOR MAP

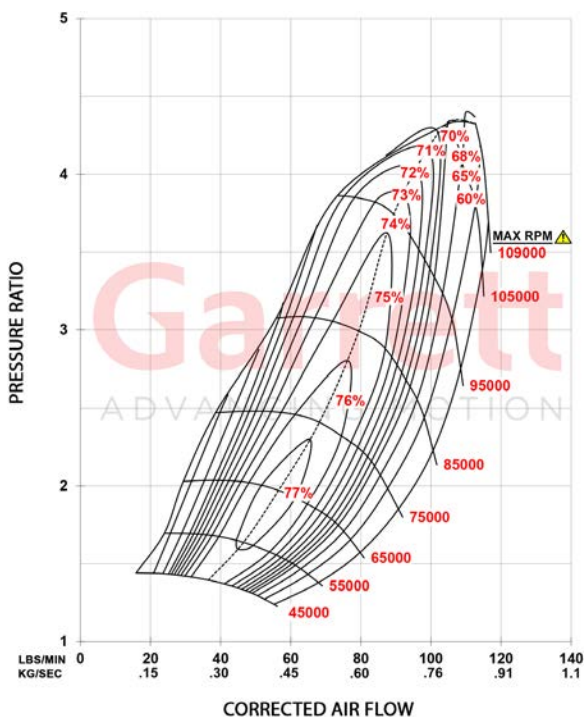

FEATURES:

- ◆ COMPRESSOR AERO INCREASES FLOW UP TO 15% (COMPARED TO GTX4502R 72MM)
- ◆ 72MM COMPRESSOR INDUCER | 102MM COMPRESSOR EXDUCER
- ◆ 10MM CERAMIC DUAL BALL BEARING WITH STEEL CAGES
- ◆ G-SERIES TURBINE AERO INCREASES FLOW 14% (COMPARED TO GTX45R)
- ◆ 89MM INCONEL TURBINE WHEEL INDUCER FLOWS UP TO 56 LBS/MIN
- ◆ LIGHTWEIGHT ALUMINUM BACKPLATE
- ◆ STAINLESS STEEL V-BAND AND T4 TWIN SCROLL TURBINE HOUSINGS

EXHAUST FLOW CHART

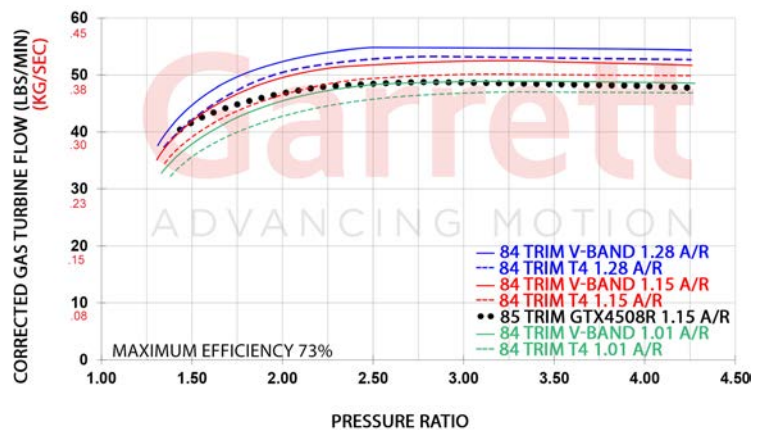

G45-1350	Compressor				Inducer	Turbine		Trim	
	HP: 650-1350	Disp: 2.0L-8.0L	Inducer	Exducer		Trim	A/R		Inducer
Supercore			72mm	102mm	51	0.85	89mm	82mm	84
Standard Rotation			PN 888169-5004S						
Turbine Kits: G45					A/R	Inlet	Outlet	Wastegate	Divided
Free Float			757707-0019		1.01	V-Band	V-Band	External	N
			757707-0020		1.15	V-Band	V-Band	External	N
			757707-0021		1.28	V-Band	V-Band	External	N
			757707-0022		1.44	V-Band	V-Band	External	N
			757707-0023		1.01	T4	V-Band	External	Y
			757707-0024		1.15	T4	V-Band	External	Y
			757707-0025		1.28	T4	V-Band	External	Y
			757707-0026		1.44	T4	V-Band	External	Y

Garrett G45-1500

Horsepower: 750 - 1500
Displacement: 2.0L - 8.0L

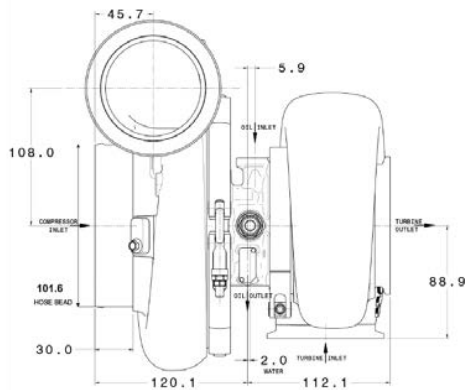

COMPRESSOR MAP

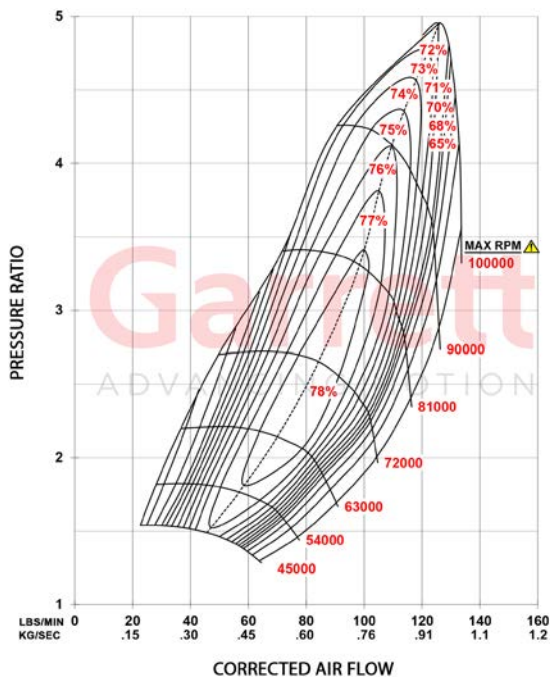

FEATURES:

- ◆ COMPRESSOR AERO INCREASES FLOW UP TO 18% (COMPARED TO GTX4508R 76MM)
- ◆ 76MM COMPRESSOR INDUCER | 102MM COMPRESSOR EXDUCER
- ◆ 10MM CERAMIC DUAL BALL BEARING WITH STEEL CAGES
- ◆ G-SERIES TURBINE AERO INCREASES FLOW 14% (COMPARED TO GTX45R)
- ◆ 89MM INCONEL TURBINE WHEEL INDUCER FLOWS UP TO 56 LBS/MIN
- ◆ LIGHTWEIGHT ALUMINUM BACKPLATE
- ◆ STAINLESS STEEL V-BAND AND T4 TWIN SCROLL TURBINE HOUSINGS

EXHAUST FLOW CHART

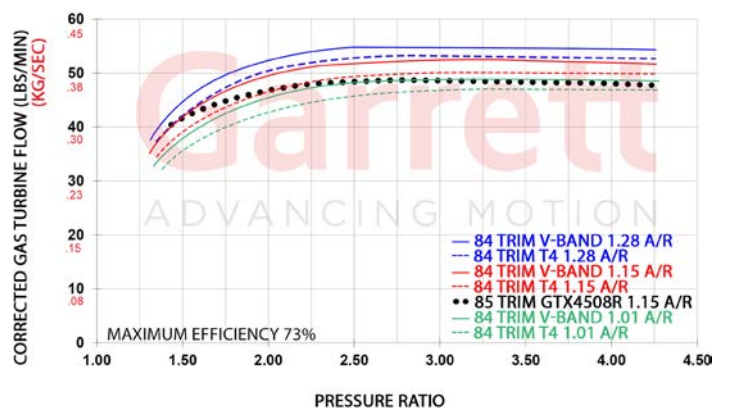

G45-1500	Compressor				Turbine				
	HP: 750-1500	Disp: 2.0L-8.0L	Inducer 76mm	Exducer 109mm	Trim 49	A/R 0.85	Inducer 89mm	Exducer 82mm	Trim 84
Supercore	PN								
Standard Rotation	888169-5005S								
Turbine Kits: G45	PN				A/R	Inlet	Outlet	Wastegate	Divided
Free Float	757707-0019		1.01		V-Band	V-Band	External	N	
	757707-0020		1.15		V-Band	V-Band	External	N	
	757707-0021		1.28		V-Band	V-Band	External	N	
	757707-0022		1.44		V-Band	V-Band	External	N	
	757707-0023		1.01		T4	V-Band	External	Y	
	757707-0024		1.15		T4	V-Band	External	Y	
	757707-0025		1.28		T4	V-Band	External	Y	
	757707-0026		1.44		T4	V-Band	External	Y	

Garrett G45-1475

Horsepower: 750 - 1475
Displacement: 2.0L - 8.0L

Garrett
ADVANCING MOTION

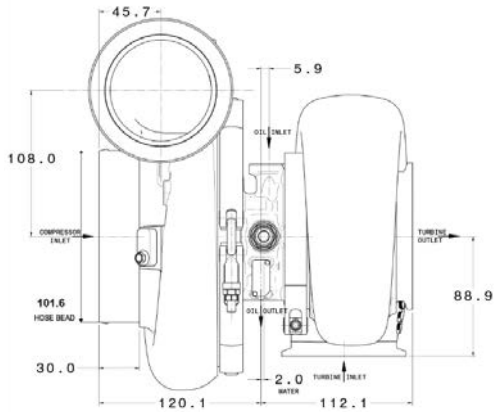

COMPRESSOR MAP

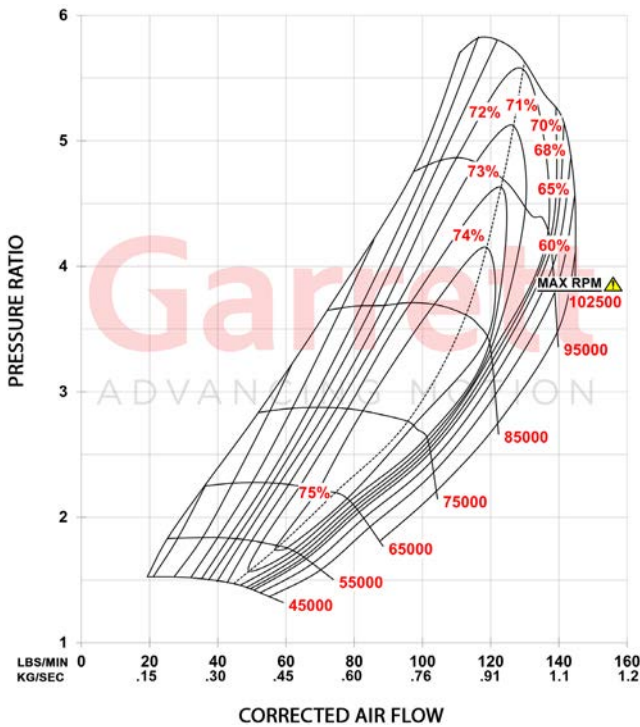

FEATURES:

- ◆ 79MM COMPRESSOR INDUCER | 98MM COMPRESSOR EXDUCER
- ◆ LARGER 65 TRIM COMPRESSOR WHEEL
- ◆ 10MM CERAMIC DUAL BALL BEARING WITH STEEL CAGES
- ◆ G-SERIES TURBINE AERO INCREASES FLOW 14% (COMPARED TO GTX45R)
- ◆ 89MM INCONEL TURBINE WHEEL INDUCER FLOWS UP TO 56 LBS/MIN
- ◆ LIGHTWEIGHT ALUMINUM BACKPLATE
- ◆ STAINLESS STEEL V-BAND AND T4 TWIN SCROLL TURBINE HOUSINGS

EXHAUST FLOW CHART

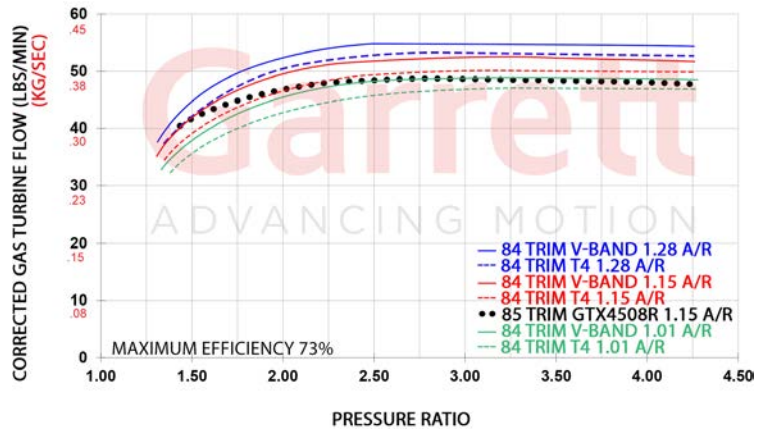

G45-1475	Compressor				Turbine				
	HP: 750-1475	Disp: 2.0L-8.0L	Inducer	Exducer	Trim	A/R	Inducer	Exducer	Trim
			79mm	98mm	65	0.85	89mm	82mm	84
Supercore	PN								
Standard Rotation	888169-5007S								
Turbine Kits:	PN		A/R	Inlet	Outlet	Wastegate	Divided		
Free Float	757707-0019		1.01	V-Band	V-Band	External	N		
	757707-0020		1.15	V-Band	V-Band	External	N		
	757707-0021		1.28	V-Band	V-Band	External	N		
	757707-0022		1.44	V-Band	V-Band	External	N		
	757707-0023		1.01	T4	V-Band	External	Y		
	757707-0024		1.15	T4	V-Band	External	Y		
	757707-0025		1.28	T4	V-Band	External	Y		
	757707-0026		1.44	T4	V-Band	External	Y		

Garrett G45-1600

Horsepower: 750 - 1600
Displacement: 2.0L - 8.0L

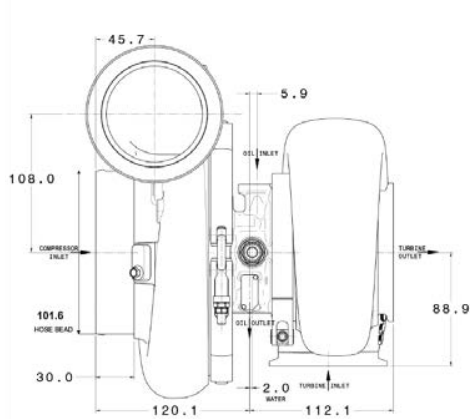

COMPRESSOR MAP

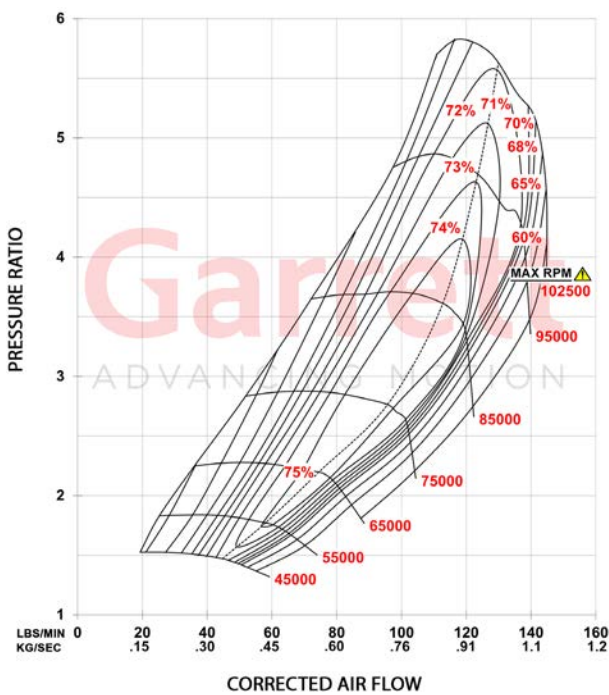

FEATURES:

- ◆ COMPRESSOR AERO INCREASES FLOW UP TO 16% (COMPARED TO GTX4508R 76MM)
- ◆ 80MM COMPRESSOR INDUCER | 102MM COMPRESSOR EXDUCER
- ◆ 10MM CERAMIC DUAL BALL BEARING WITH STEEL CAGES
- ◆ G-SERIES TURBINE AERO INCREASES FLOW 14% (COMPARED TO GTX45R)
- ◆ 89MM INCONEL TURBINE WHEEL INDUCER FLOWS UP TO 56 LBS/MIN
- ◆ LIGHTWEIGHT ALUMINUM BACKPLATE
- ◆ STAINLESS STEEL V-BAND AND T4 TWIN SCROLL TURBINE HOUSINGS

EXHAUST FLOW CHART

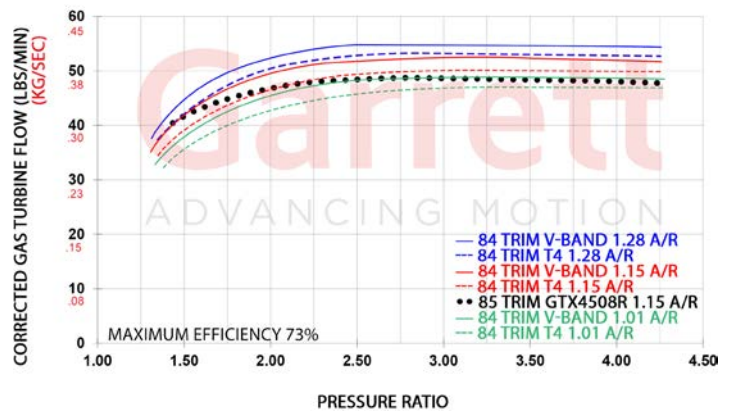

G45-1600	Compressor				Turbine				
	HP: 750-1600	Disp: 2.0L-8.0L	Inducer 80mm	Exducer 109mm	Trim 54	A/R 0.85	Inducer 89mm	Exducer 82mm	Trim 84
Supercore	PN								
Standard Rotation	888169-5006S								
Turbine Kits: G45	PN				A/R	Inlet	Outlet	Wastegate	Divided
Free Float	757707-0019		1.01		V-Band	V-Band	External	N	
	757707-0020		1.15		V-Band	V-Band	External	N	
	757707-0021		1.28		V-Band	V-Band	External	N	
	757707-0022		1.44		V-Band	V-Band	External	N	
	757707-0023		1.01		T4	V-Band	External	Y	
	757707-0024		1.15		T4	V-Band	External	Y	
	757707-0025		1.28		T4	V-Band	External	Y	
	757707-0026		1.44		T4	V-Band	External	Y	

Garrett G47

Horsepower: 825 - 1850
Displacement: 2.5L - 10.0L

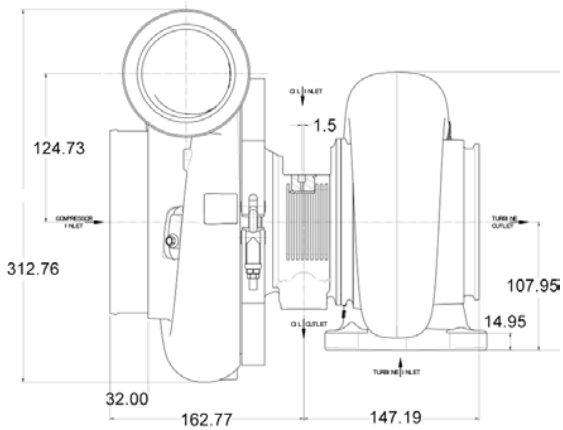

COMPRESSOR MAP

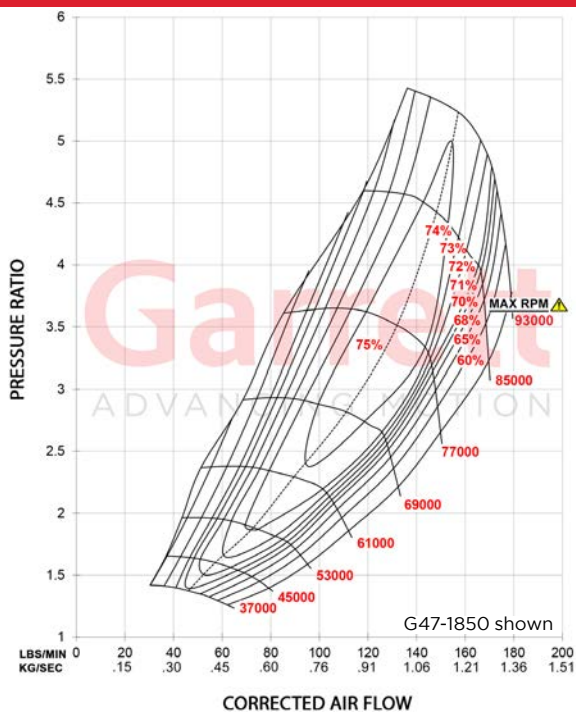

FEATURES:

- ◆ OUTLINE INTERCHANGEABLE WITH GTX GEN II TURBOS
- ◆ 76MM | 80MM COMP IND | 109MM COMP EXD
- ◆ 80MM | 88MM COMP IND | 120 COMP EXD
- ◆ HIGH FLOW, HIGH EFFICIENCY GTX GEN II COMP AERO
- ◆ G-SERIES TURBINE WHEEL AERO INCREASES PERFORMANCE COMPARED TO GTX47 GEN II: • FLOW: UP TO 20% MORE • SPOOL: UP TO +9% (ESTIMATED BY FLOW, EFFICIENCY, AND INERTIA)
- ◆ ONE-PIECE LIGHTWEIGHT ALUMINUM CENTER HSG/BACKPLATE

EXHAUST FLOW CHART

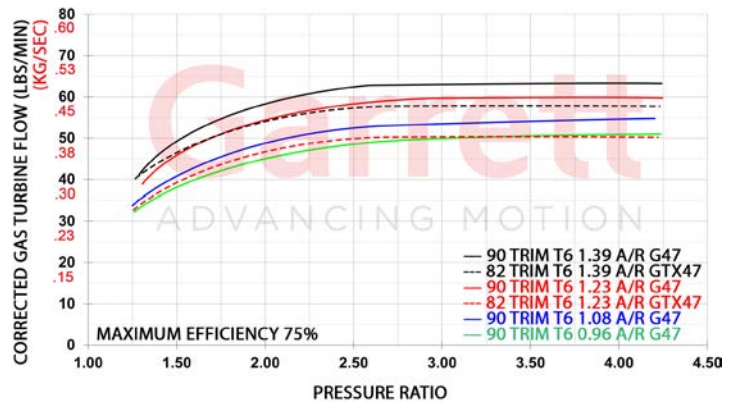

G-Series G47		Compressor			Turbine		
HP: 825-1850	Disp: 2.5L-10.0L	Inducer	Exducer	A/R	Inducer	Exducer	Trim
Supercore PN							
G47-1550	880547-5023S	76mm	109mm	0.88	93mm	88mm	90
G47-1650	880547-5024S	80mm	109mm	0.88	93mm	88mm	90
G47-1650	880547-5025S	80mm	120mm	0.88	93mm	88mm	90
G47-1850	880547-5026S	88mm	120mm	0.88	93mm	88mm	90
Turbine Kits: G47		PN	A/R	Inlet	Outlet	Wastegate	Divided
Free Float		761208-0075	0.96	T6	V-Band	External	N
		761208-0076	1.08	T6	V-Band	External	N
		761208-0077	1.23	T6	V-Band	External	N
		761208-0078	1.39	T6	V-Band	External	N

COMPRESSOR MAPS:



G47-1550 76mm



G47-1650
80/109mm



G47-1650
80/120mm



G47-1850 88mm

Garrett G50

Horsepower: 875 - 1900
 Displacement: 2.5L - 11.0L

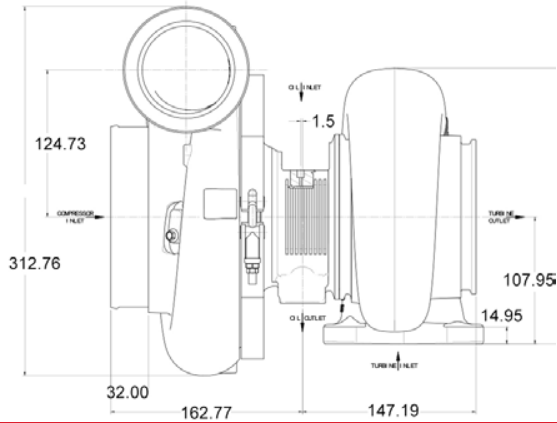

COMPRESSOR MAP

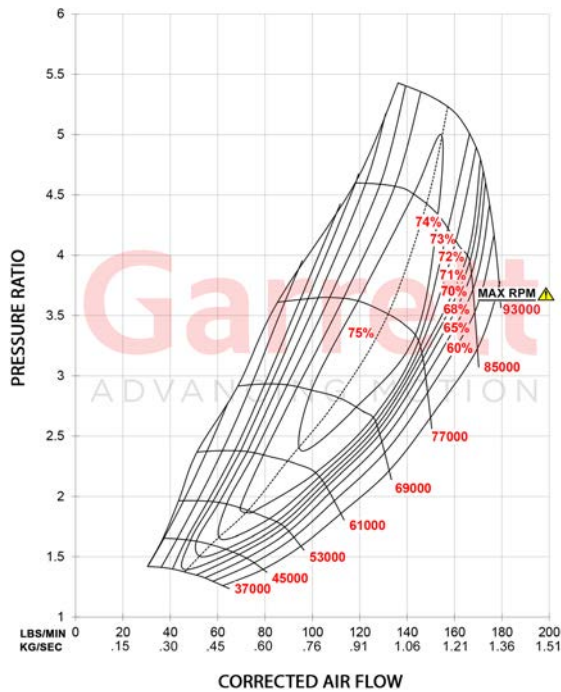

FEATURES:

- ◆ OUTLINE INTERCHANGEABLE WITH GTX GEN II TURBOS
- ◆ 80MM COMP IND | 109MM COMP EXD
- ◆ 88MM COMP IND | 120MM COMP EXD
- ◆ HIGH FLOW, HIGH EFFICIENCY GTX GEN II COMP AERO
- ◆ G-SERIES TURBINE WHEEL AERO INCREASES PERFORMANCE COMPARED TO GTX50 GEN II: • FLOW: UP TO 23% MORE • SPOOL: UP TO +12% (ESTIMATED BY FLOW, EFFICIENCY, AND INERTIA)
- ◆ ONE-PIECE LIGHTWEIGHT ALUMINUM CENTER HSG/BACKPLATE

EXHAUST FLOW CHART

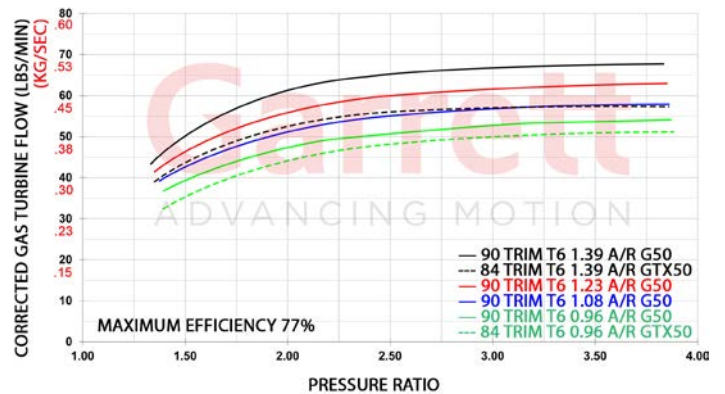

G-Series G50		Compressor			Turbine		
HP: 875-1900	Disp: 2.5L-10.0L	Inducer	Exducer	A/R	Inducer	Exducer	Trim
Supercore	PN						
G50-1700	880547-5027S	80mm	109mm	0.88	99mm	94mm	90
G50-1900	880547-5028S	88mm	120mm	0.88	99mm	94mm	90
Turbine Kits: G50		PN	A/R	Inlet	Outlet	Wastegate	Divided
Free Float	761208-0079		0.96	T6	V-Band	External	N
	761208-0080		1.08	T6	V-Band	External	N
	761208-0081		1.23	T6	V-Band	External	N
	761208-0082		1.39	T6	V-Band	External	N

COMPRESSOR MAPS:



G47-1650
80/109mm



G47-1850 88mm

Garrett G55

Horsepower: 1000 - 2900
Displacement: 3.0L - 12.0L

Garrett

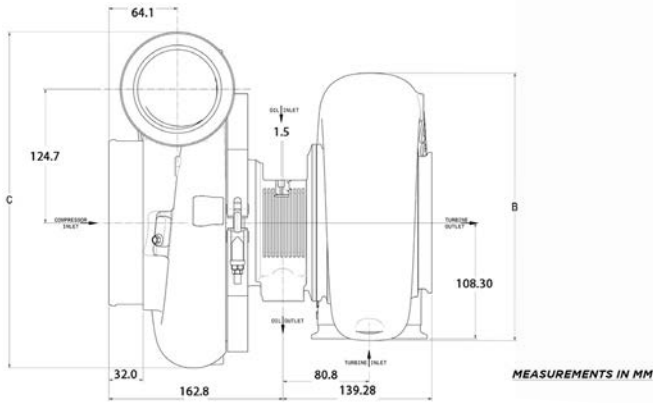

COMPRESSOR MAP

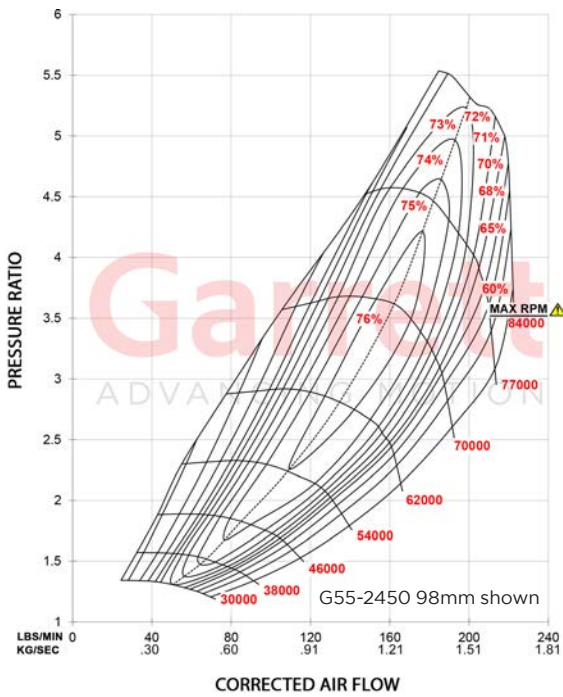

FEATURES:

- ◆ 85MM, 88MM, 91MM, 94MM, 98MM, 102MM, 106MM COMPRESSOR SIZES
- ◆ GTX GEN II COMPRESSOR AERODYNAMICS
- ◆ 106MM TURBINE EXDUCER (+4MM COMPARED TO GTX55)
- ◆ 15% MORE TURBINE FLOW (COMPARED TO GTX)
- ◆ 6% INCREASE IN SPOOL-UP PERFORMANCE
- ◆ STAINLESS STEEL TURBINE HOUSINGS IN T6 AND V-BAND INLET
- ◆ ONE-PIECE ALUMINUM CENTER HOUSING (28% LIGHTER)
- ◆ 16MM CERAMIC DUAL BALL BEARING WITH STEEL CAGES
- ◆ OUTLINE INTERCHANGEABLE WITH GTX GEN II TURBOS

EXHAUST FLOW CHART

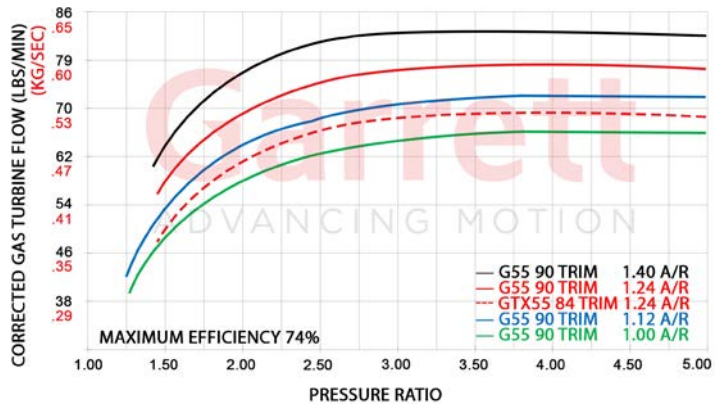

G Series G55 HP: 1000-2900 Disp: 3.0L-12.0L		Compressor			Turbine		
		Inducer	Exducer	A/R	Inducer	Exducer	Trim
Supercore	PN						
G55-1850	880547-5001S	85mm	133mm	0.88	112mm	106mm	90
G55-1950	880547-5002S	88mm	133mm	0.88	112mm	106mm	90
G55-2100	880547-5003S	91mm	133mm	0.96	112mm	106mm	90
G55-2250	880547-5004S	94mm	133mm	0.96	112mm	106mm	90
G55-2450	880547-5005S	98mm	133mm	0.96	112mm	106mm	90
G55-2650	880547-5021S	102mm	144mm	0.96	112mm	106mm	90
G55-2900	880547-5022S	106mm	144mm	0.96	112mm	106mm	90
Turbine Kits: G55		PN	A/R	Inlet	Outlet	Wastegate	Divided
Free Float		761208-0069	1.24	V-Band	V-Band	External	N
		761208-0070	1.40	V-Band	V-Band	External	N
		761208-0071	1.00	T6	V-Band	External	N
		761208-0072	1.12	T6	V-Band	External	N
		761208-0073	1.24	T6	V-Band	External	N
		761208-0074	1.40	T6	V-Band	External	N

COMPRESSOR MAPS:



G55-1850 85mm



G55-1950 88mm



G55-2100 91mm



G55-2250 94mm



G55-2650 102mm



G55-2900 106mm

Garrett G57

Horsepower: 1400 - 3000
Displacement: 3.0L - 12.0L

Garrett

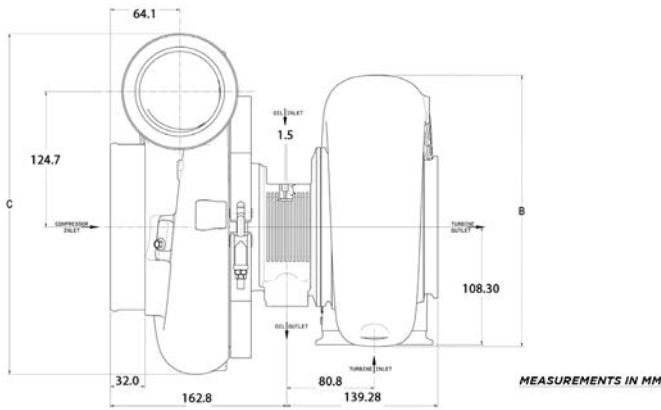

COMPRESSOR MAP

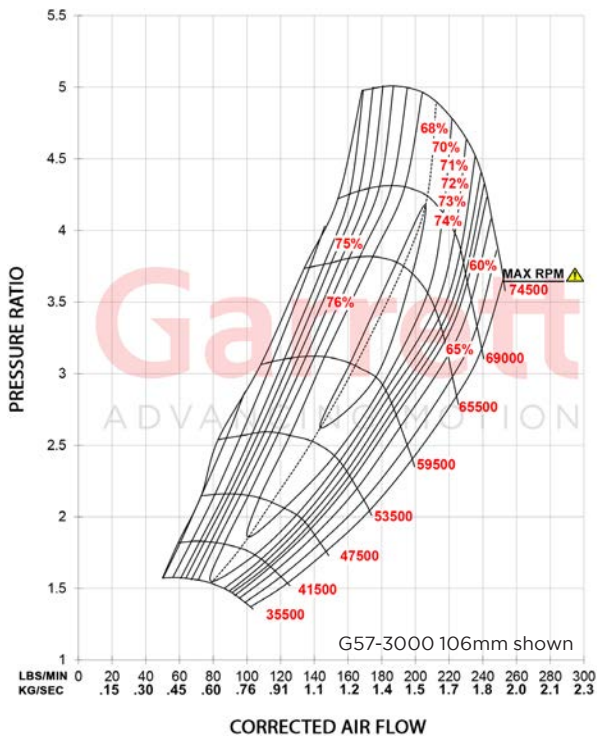

FEATURES:

- ◆ 88MM, 94MM, 102MM, 106MM COMPRESSOR OPTIONS
- ◆ 118MM INDUCER TURBINE WHEEL
- ◆ 28% MORE TURBINE FLOW (COMPARED TO GTX) SEE GRAPH BELOW
- ◆ STAINLESS STEEL TURBINE HOUSINGS
- ◆ ONE-PIECE ALUMINUM CENTER HOUSING
- ◆ 16MM CERAMIC DUAL BALL BEARING WITH STEEL CAGES
- ◆ OUTLINE INTERCHANGEABLE WITH GTX GEN II TURBOS
- ◆ STAINLESS STEEL TURBINE KIT SOLD INDIVIDUALLY. 1.09 A/R, 1.25 A/R, 1.41 A/R

EXHAUST FLOW CHART

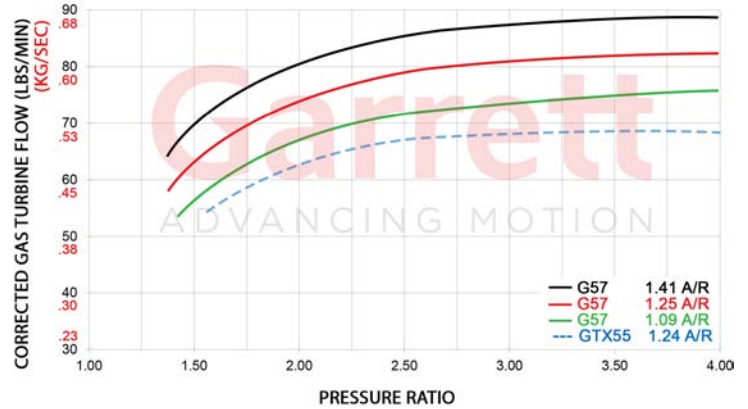

G Series G57		Compressor			Turbine		
HP: 1400-3000	Disp: 3.0L-12.0L	Inducer	Exducer	A/R	Inducer	Exducer	Trim
Supercore	PN						
G57-2000	880547-5031S	88mm	133mm	0.88	118mm	112mm	90
G57-2350	880547-5032S	94mm	133mm	0.96	118mm	112mm	90
G57-2550	880547-5033S	98mm	133mm	0.96	118mm	112mm	90
G57-2750	880547-5029S	102mm	144mm	0.96	118mm	112mm	90
G57-3000	880547-5030S	106mm	144mm	0.96	118mm	112mm	90
Turbine Kits: G57		PN	A/R	Inlet	Outlet	Wastegate	Divided
Free Float		761208-0083	1.09	V-Band	V-Band	External	N
		761208-0084	1.25	V-Band	V-Band	External	N
		761208-0085	1.41	V-Band	V-Band	External	N

COMPRESSOR MAPS:



G57-2000 88mm



G57-2350 94mm



G57-2550 98mm



G57-2750 102mm

G-XRACE

When Xtreme Power Meets Xtreme Performance

Winners aren't born – they are built. Reputations are forged through skill, speed and consistency. Racers push their skills, their cars, and their turbos to extreme limits. When the stakes are high, only the best turbo will take you to the finish line. Garrett G-XRace is built for those who know that winning comes from being the quickest, pass after pass, race after race.



GXRACE



Garrett GXR40-64

Horsepower: 500-1150
Displacement: 2.0L - 6.0L

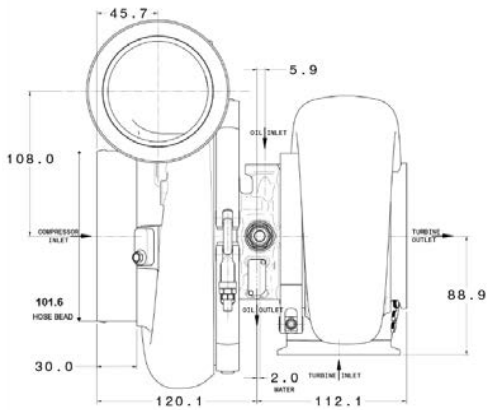

COMPRESSOR MAP

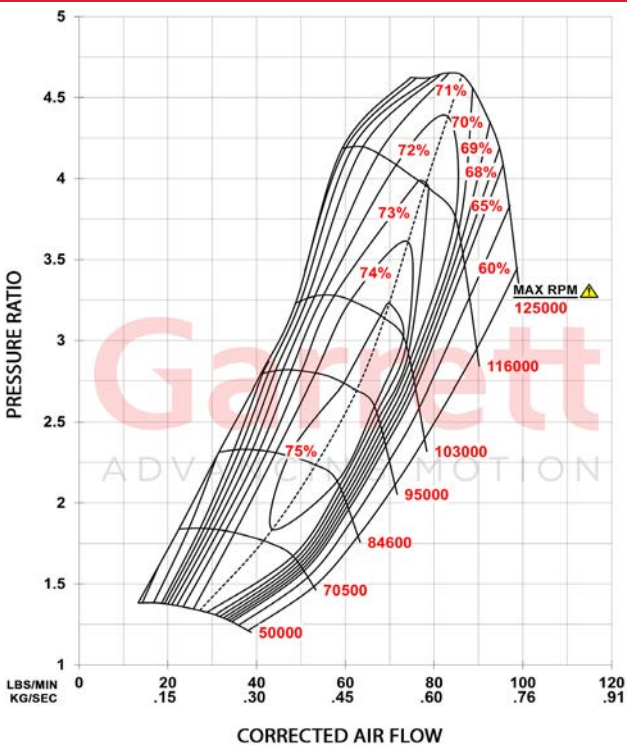

FEATURES:

- ◆ XBOOST TECHNOLOGY INCREASES POWER AND PERFORMANCE
- ◆ +23% COMPRESSOR FLOW (GXR40-64 COMPARED TO G40-900)
- ◆ ENHANCED PRESSURE RATIO CAPABILITY AND HIGHER BOOST PRESSURE
- ◆ INCREASED EFFICIENCY AT HIGH FLOW RATES
- ◆ LOWER INTAKE TEMPERATURE
- ◆ LIGHTWEIGHT ALUMINUM BACKPLATE
- ◆ FULLY MACHINED FLANGE-STYLE SPEED SENSOR PORT FOR EASY SENSOR INSTALLATION AND MONITORING TURBO SPEED
- ◆ UTILIZES THE SAME TWIN-SCROLL T4 AND V-BAND TURBINE HOUSINGS AS G-SERIES TO ENABLE AN EASY UPGRADE

EXHAUST FLOW CHART

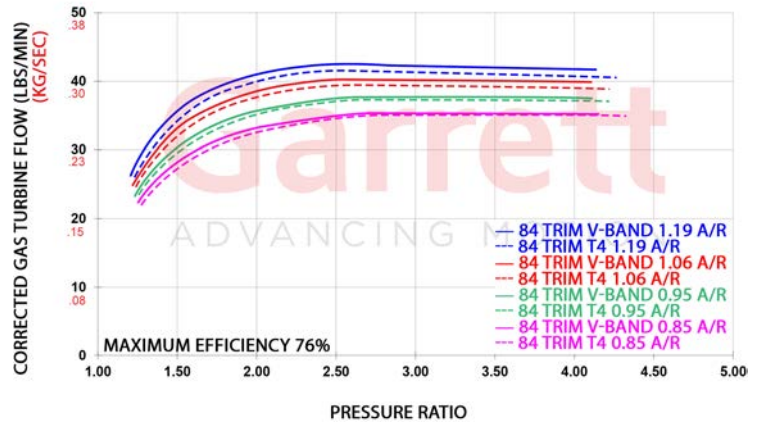

GXR40-64	Compressor					Turbine			
	HP: 500-1150	Disp: 2.0L-6.0L	Inducer	Exducer	Trim	A/R	Inducer	Exducer	Trim
			64.9mm	88mm	53	0.85	77mm	70mm	84
Supercore	PN								
Standard Rotation	934173-5005S								
Turbine Kits:	PN		A/R	Inlet	Outlet	Wastegate	Divided		
Free Float	757707-0027		0.85	V-Band	V-Band	External	N		
	757707-0028		0.95	V-Band	V-Band	External	N		
	757707-0029		1.06	V-Band	V-Band	External	N		
	757707-0030		1.19	V-Band	V-Band	External	N		
	757707-0032		0.85	T4	V-Band	External	Y		
	757707-0033		0.95	T4	V-Band	External	Y		
	757707-0034		1.06	T4	V-Band	External	Y		
	757707-0035		1.19	T4	V-Band	External	Y		

Approved for use in drag racing classes with compressor wheel inducer limits 64.9. Please verify class rules before purchasing.

Garrett GXR42-68

Horsepower: 650 - 1400

Displacement: 2.0L - 7.0L

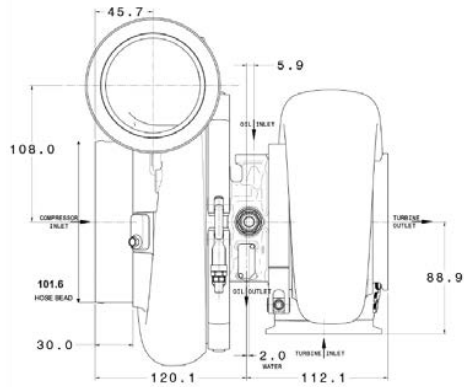

COMPRESSOR MAP

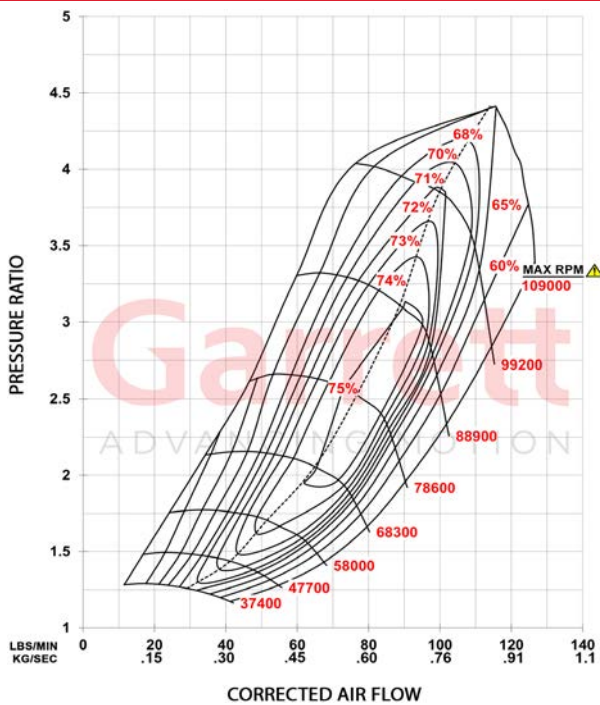

FEATURES:

- ◆ XBOOST TECHNOLOGY INCREASES POWER AND PERFORMANCE
- ◆ ENHANCED PRESSURE RATIO CAPABILITY AND HIGHER BOOST PRESSURE
- ◆ INCREASED EFFICIENCY AT HIGH FLOW RATES
- ◆ LOWER INTAKE TEMPERATURE
- ◆ LIGHTWEIGHT ALUMINUM BACKPLATE
- ◆ TWIN-SCROLL T4 AND V-BAND TURBINE INLET FLANGES AVAILABLE FOR RACERS WITH DIFFERENT ENGINES AND MANIFOLD DESIGNS

EXHAUST FLOW CHART

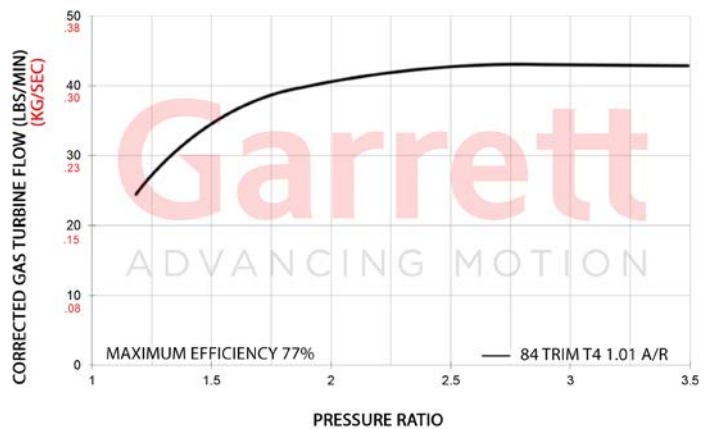

GXR42-68	Compressor				Turbine				
	HP: 650-1400	Disp: 2.0L-7.0L	Inducer	Exducer	Trim	A/R	Inducer	Exducer	Trim
			68.9mm	102mm	45	0.85	82mm	75mm	84
Supercore	PN								
Standard Rotation	934173-5001S								
Turbine Kits:			PN	A/R	Inlet	Outlet	Wastegate	Divided	
Free Float			757707-0011	1.01	V-Band	V-Band	External	N	
			757707-0012	1.15	V-Band	V-Band	External	N	
			757707-0013	1.28	V-Band	V-Band	External	N	
			757707-0014	1.01	T4	V-Band	External	Y	
			757707-0015	1.15	T4	V-Band	External	Y	
			757707-0016	1.28	T4	V-Band	External	Y	

Garrett GXR42-72

Horsepower: 700 - 1450
Displacement: 2.0L - 7.0L

Garrett
ADVANCING MOTION

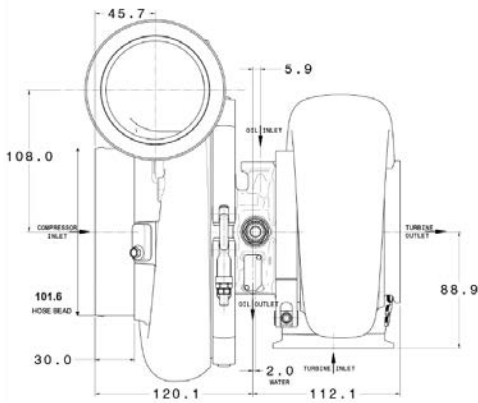

COMPRESSOR MAP

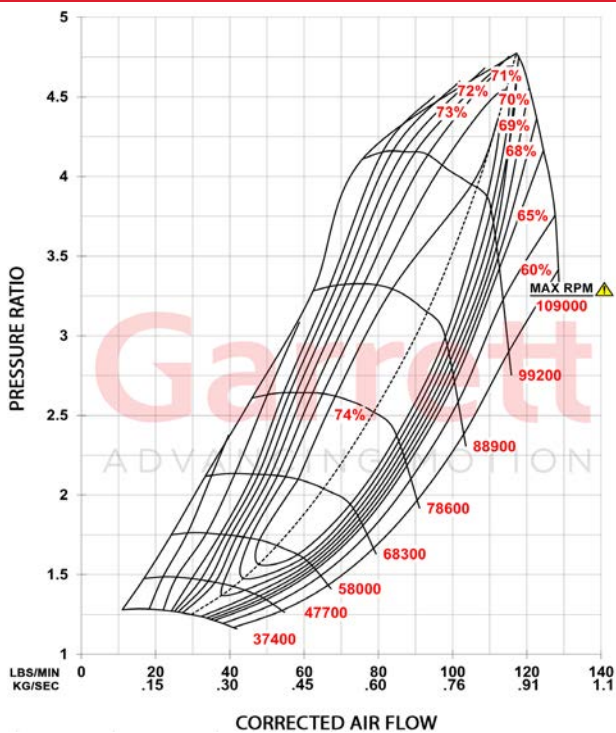

FEATURES:

- ◆ XBOOST TECHNOLOGY INCREASES POWER AND PERFORMANCE
- ◆ ENHANCED PRESSURE RATIO CAPABILITY AND HIGHER BOOST PRESSURE
- ◆ INCREASED EFFICIENCY AT HIGH FLOW RATES
- ◆ LOWER INTAKE TEMPERATURE
- ◆ LIGHTWEIGHT ALUMINUM BACKPLATE
- ◆ TWIN-SCROLL T4 AND V-BAND TURBINE INLET FLANGES AVAILABLE FOR RACERS WITH DIFFERENT ENGINES AND MANIFOLD DESIGNS

EXHAUST FLOW CHART

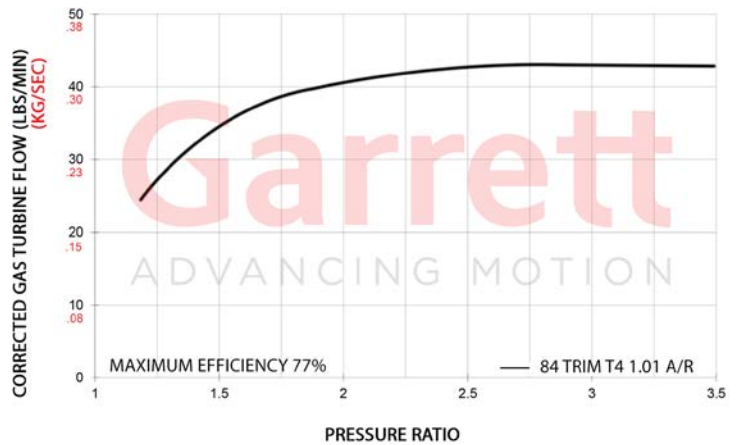

GXR42-72	Compressor				Turbine		
	Inducer	Exducer	Trim	A/R	Inducer	Exducer	Trim
HP: 700-1450 Disp: 2.0L-7.0L	72.9mm	102mm	51	0.85	82mm	75mm	84
Supercore	PN						
Standard Rotation	934173-5002S						
Turbine Kits:	PN		A/R	Inlet	Outlet	Wastegate	Divided
Free Float	757707-0011		1.01	V-Band	V-Band	External	N
	757707-0012		1.15	V-Band	V-Band	External	N
	757707-0013		1.28	V-Band	V-Band	External	N
	757707-0014		1.01	T4	V-Band	External	Y
	757707-0015		1.15	T4	V-Band	External	Y
	757707-0016		1.28	T4	V-Band	External	Y

Garrett GXR45-67

Horsepower: 725 - 1475

Displacement: 2.0L - 8.0L

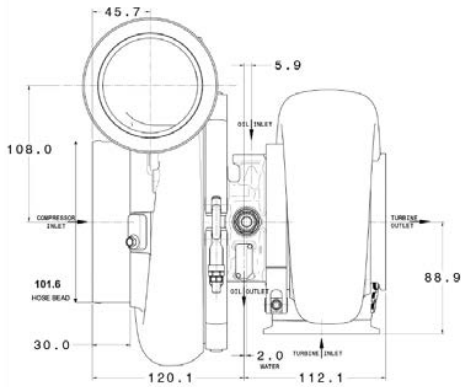

COMPRESSOR MAP

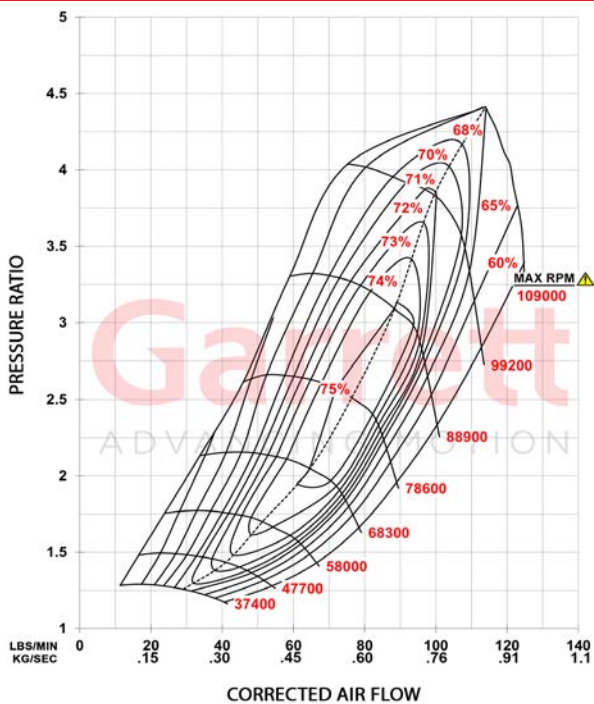

FEATURES:

- ◆ XBOOST TECHNOLOGY INCREASES POWER AND PERFORMANCE
- ◆ ENHANCED PRESSURE RATIO CAPABILITY AND HIGHER BOOST PRESSURE
- ◆ INCREASED EFFICIENCY AT HIGH FLOW RATES
- ◆ LOWER INTAKE TEMPERATURE
- ◆ LIGHTWEIGHT ALUMINUM BACKPLATE
- ◆ TWIN-SCROLL T4 AND V-BAND TURBINE INLET FLANGES AVAILABLE FOR RACERS WITH DIFFERENT ENGINES AND MANIFOLD DESIGNS

EXHAUST FLOW CHART

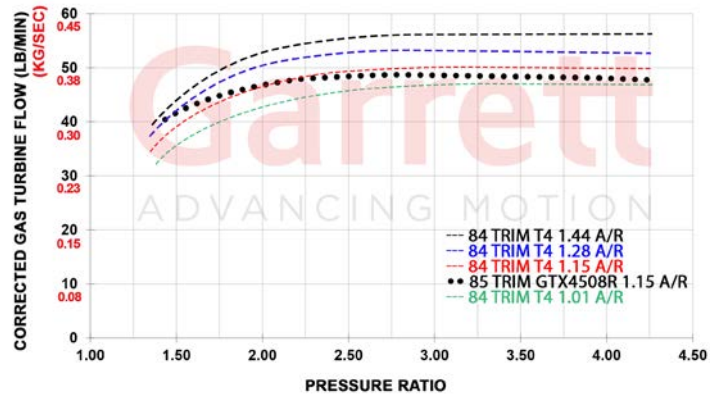

GXR45-67	Compressor				Turbine				
	HP: 725-1425	Disp: 2.0L-8.0L	Inducer	Exducer	Trim	A/R	Inducer	Exducer	Trim
			67.9mm	102mm	44	0.85	89mm	82mm	84
Supercore			PN						
			934173-5003S		For classes with no map groove rule				
Optional Compressor Housing			PN						
0.25" Map Groove			934809-0009		For classes with 0.25" map groove rule (FL2K, PanAm, etc)				
Turbine Kits:			PN	A/R	Inlet	Outlet	Wastegate	Divided	
Free Float			757707-0019	1.01	V-Band	V-Band	External	N	
			757707-0020	1.15	V-Band	V-Band	External	N	
			757707-0021	1.28	V-Band	V-Band	External	N	
			757707-0022	1.44	V-Band	V-Band	External	N	
			757707-0023	1.01	T4	V-Band	External	Y	
			757707-0024	1.15	T4	V-Band	External	Y	
			757707-0025	1.28	T4	V-Band	External	Y	
			757707-0025	1.28	T4	V-Band	External	Y	

Garrett GXR45-73

Horsepower: 750 - 1550
Displacement: 2.0L - 8.0L

Garrett
ADVANCING MOTION

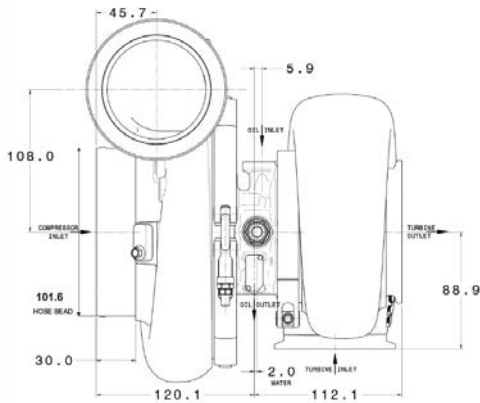

COMPRESSOR MAP

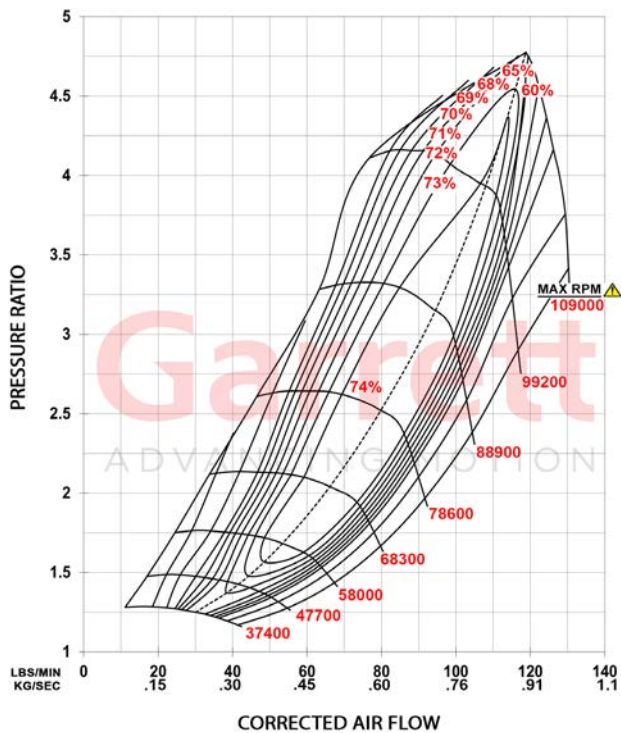

FEATURES:

- ◆ XBOOST TECHNOLOGY INCREASES POWER AND PERFORMANCE
- ◆ ENHANCED PRESSURE RATIO CAPABILITY AND HIGHER BOOST PRESSURE
- ◆ INCREASED EFFICIENCY AT HIGH FLOW RATES
- ◆ LOWER INTAKE TEMPERATURE
- ◆ LIGHTWEIGHT ALUMINUM BACKPLATE
- ◆ TWIN-SCROLL T4 AND V-BAND TURBINE INLET FLANGES AVAILABLE FOR RACERS WITH DIFFERENT ENGINES AND MANIFOLD DESIGNS

EXHAUST FLOW CHART

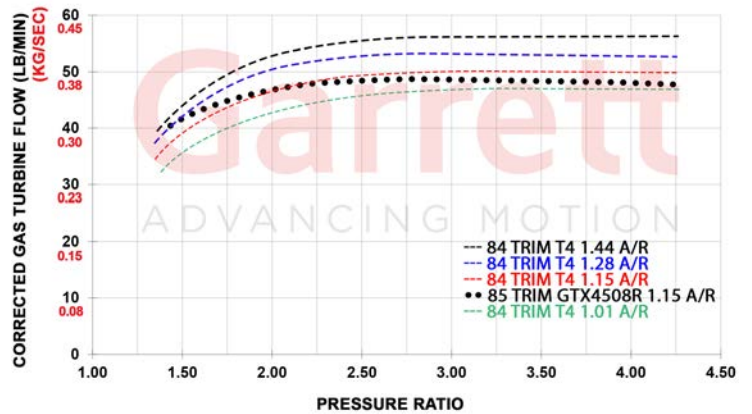

GXR45-73	Compressor				Turbine				
	HP: 750-1500	Disp: 2.0L-8.0L	Inducer	Exducer	Trim	A/R	Inducer	Exducer	Trim
			73.9mm	102mm	52	0.85	89mm	82mm	84
Supercore			PN						
			934173-5004S		For classes with no map groove rule				
Optional Compressor Housing			PN						
0.25" Map Groove			934809-0010		For classes with 0.25" map groove rule (FL2K, PanAm, etc)				
Turbine Kits:			PN		A/R	Inlet	Outlet	Wastegate	Divided
Free Float			757707-0019		1.01	V-Band	V-Band	External	N
			757707-0020		1.15	V-Band	V-Band	External	N
			757707-0021		1.28	V-Band	V-Band	External	N
			757707-0022		1.44	V-Band	V-Band	External	N
			757707-0023		1.01	T4	V-Band	External	Y
			757707-0024		1.15	T4	V-Band	External	Y
			757707-0025		1.28	T4	V-Band	External	Y
			757707-0025		1.28	T4	V-Band	External	Y

Garrett GXR55-88

Horsepower: 1000 - 2350
Displacement: 3.0L - 12.0L

Garrett

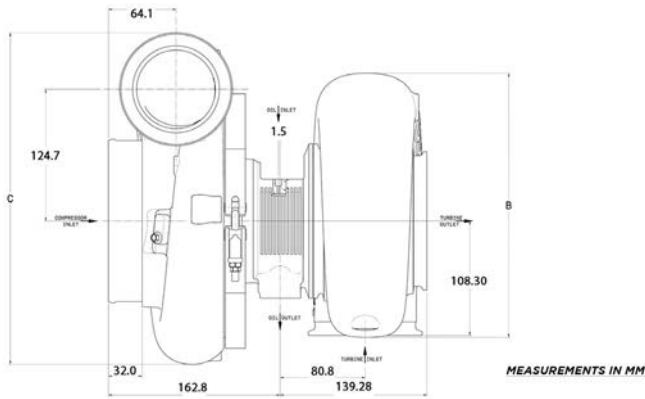

FEATURES:

- ◆ XBOOST TECHNOLOGY INCREASES POWER AND PERFORMANCE
- ◆ +21% COMPRESSOR FLOW (GXR55-88 COMPARED TO G55-1950)
- ◆ ENHANCED PRESSURE RATIO CAPABILITY AND HIGHER BOOST PRESSURE
- ◆ INCREASED EFFICIENCY AT HIGH FLOW RATES
- ◆ LOWER INTAKE TEMPERATURE
- ◆ LIGHTWEIGHT ALUMINUM BACKPLATE
- ◆ FULLY MACHINED FLANGE-STYLE SPEED SENSOR PORT FOR EASY SENSOR INSTALLATION AND MONITORING TURBO SPEED
- ◆ FOR USE IN DRAG RACE CLASSES LDR (LIMITED DRAG RADIAL), X275, AND CLASSES WITH 88MM COMPRESSOR INDUCER RULE. PLEASE VERIFY CLASS RULES BEFORE PURCHASING

COMPRESSOR MAP

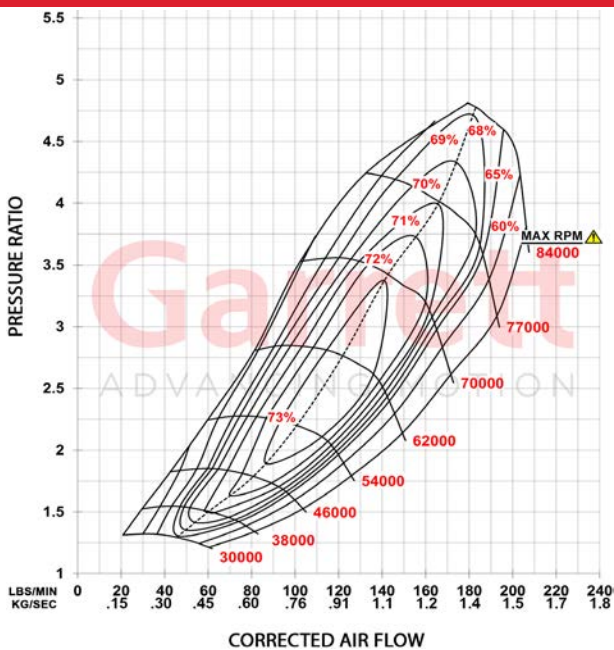

EXHAUST FLOW CHART

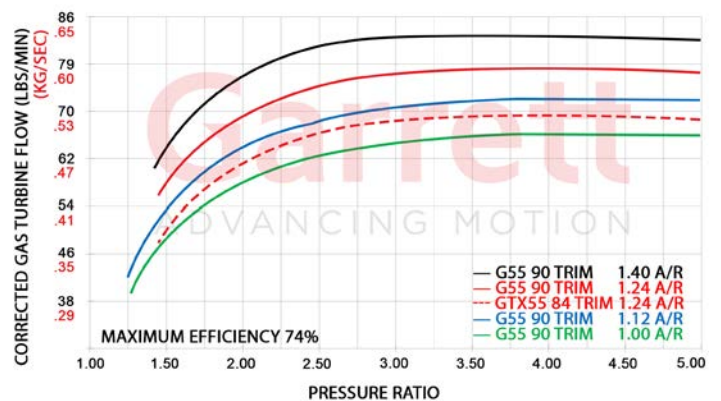

GXR55-88	Compressor				Turbine		
	Inducer	Exducer	Trim	A/R	Inducer	Exducer	Trim
HP: 1000-2350 Disp: 3.0L-12.0L	88.9mm	133mm	44	0.88	112mm	103mm	86
Supercore	PN				Drag Race Class		
0.25" Map Groove	934174-5001S				LDR, X275		
0.18" Map Groove	934174-5008S				X275		
Turbine Kits:	PN	A/R	Inlet	Outlet	Wastegate	Divided	
Free Float	761208-0086	1.24	V-Band	V-Band	External	N	
	761208-0087	1.40	V-Band	V-Band	External	N	

GXR55-88	Compressor				Turbine		
	Inducer	Exducer	Trim	A/R	Inducer	Exducer	Trim
HP: 1000-2350 Disp: 3.0L-12.0L	88.9mm	133mm	44	0.88	112mm	106mm	90
Supercore	PN				Drag Race Class		
0.18" Map Groove	934174-5002S				X275		
0.25" Map Groove	934174-5007S				X275		
Turbine Kits:	PN	A/R	Inlet	Outlet	Wastegate	Divided	
Free Float	761208-0069	1.24	V-Band	V-Band	External	N	
	761208-0070	1.40	V-Band	V-Band	External	N	
	761208-0071	1.00	T6	V-Band	External	N	
	761208-0072	1.12	T6	V-Band	External	N	
	761208-0073	1.24	T6	V-Band	External	N	
	761208-0074	1.40	T6	V-Band	External	N	

GTX SERIES

GTX and GTX Gen II Series turbochargers are an evolution of the GT Series product line. The original architecture of the GT Series turbos remains however many design and performance features have been introduced over time. Ceramic dual ball bearings and forged fully-machined compressor wheels with GTX and GTX Gen II aerodynamics provide a larger horsepower range and maximize boost response.

The water cooled center housing keeps housing temperatures to a minimum. The turbine wheel is constructed from Inconel, a super alloy that maintains strength over prolonged exposure to high exhaust gas temperatures.

Turbine kits are offered in open volute and twin scroll, and a variety of A/R and flange configurations from T25, T3, T4, T6, and V-band.

GEN II PRODUCT UPDATES UPDATED FEATURES ON SELECT GTX TURBOCHARGERS



GEN II COMPRESSOR AERODYNAMICS FOR INCREASED HORSEPOWER RANGE (GTX28/30/35/47/50/ 55)
FULLY MACHINED SPEED SENSOR PORT FOR DATA ACQUISITION (GTX28/30/35/47/50/55)
LIGHTWEIGHT ALUMINUM BACKPLATE FOR WEIGHT REDUCTION (GTX47/50/55)

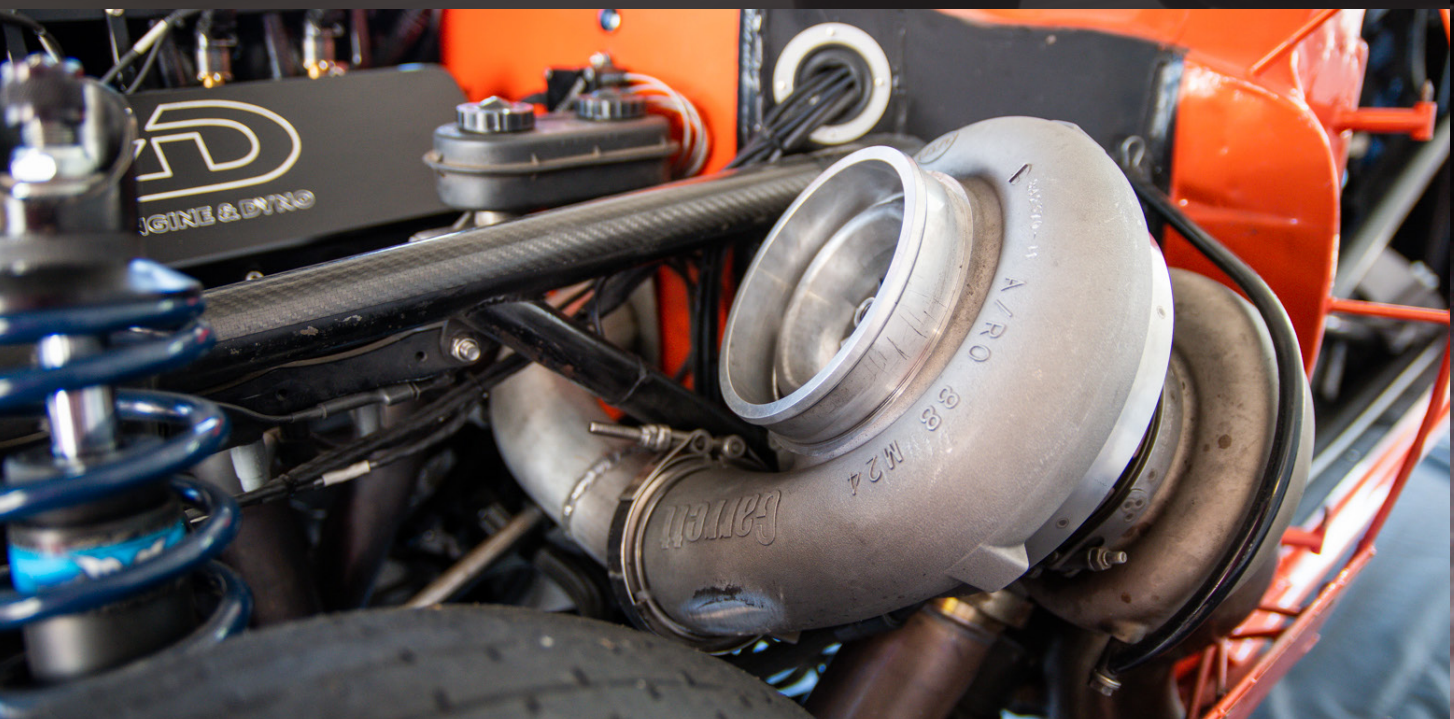

ON RACEWORKS



Garrett GTX2860R GEN II

Horsepower: 200 - 475
Displacement: 1.4L - 2.5L

Garrett
ADVANCING MOTION

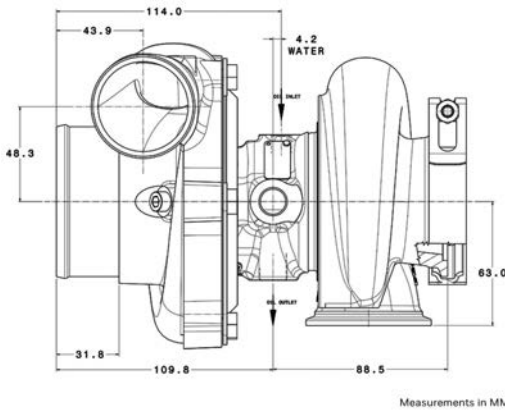

COMPRESSOR MAP

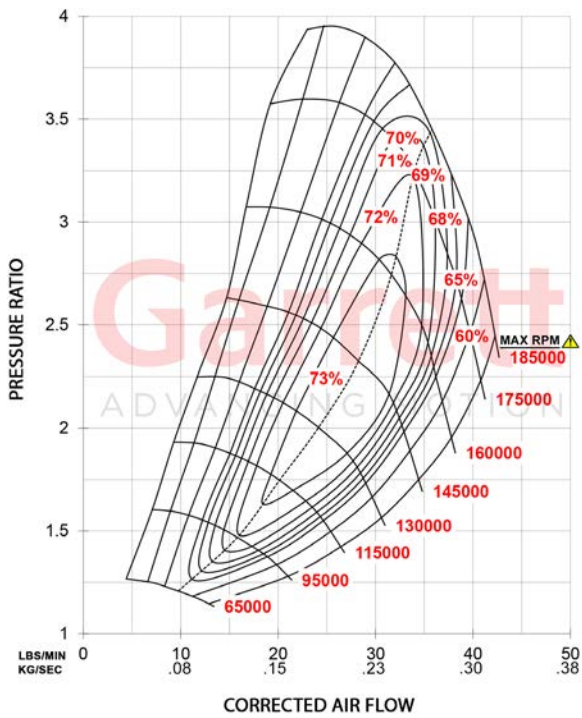

FEATURES:

- ◆ GEN 2 AERODYNAMICS FEATURE INCREASED HORSEPOWER RANGE
- ◆ IMPROVED PORTED SHROUD DESIGN FOR SURGE RESISTANCE
- ◆ FULLY-MACHINED SPEED SENSOR PORT. DETAILS ON PG. 80
- ◆ WASTEGATE ACTUATORS & BRACKET KIT AVAILABLE ON PG. 81

EXHAUST FLOW CHART

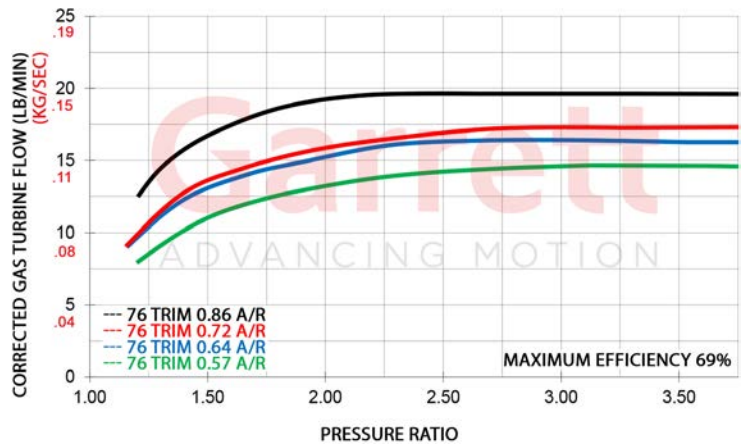

GTX2860R Gen II		Compressor				Turbine		
		Inducer	Exducer	Trim	A/R	Inducer	Exducer	Trim
HP: 200-475	Disp: 1.4L-2.5L	46mm	60mm	58	0.60	54mm	47mm	76
Supercore	Assembly Kit	Turbine Kit		A/R	Inlet	Outlet	Wastegate	Divided
849894-5001S	856800-5001S	827690-0001		0.57	V-Band	V-Band	Free Float	N
	856800-5002S	827690-0002		0.72	V-Band	V-Band	Free Float	N
Assembly Kit PN Includes	856800-5003S	827690-0003		0.64	T25	5 bolt	Wastegated	N
Supercore and Turbine Kit	856800-5004S	827690-0004		0.86	T25	5 bolt	Wastegated	N

Garrett GTX2867R GEN II

Horsepower: 275 - 550
Displacement: 1.4L - 2.5L

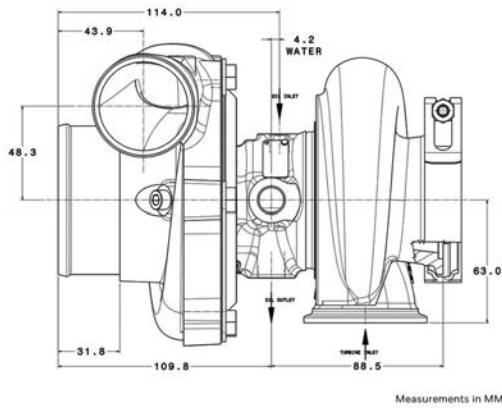

COMPRESSOR MAP

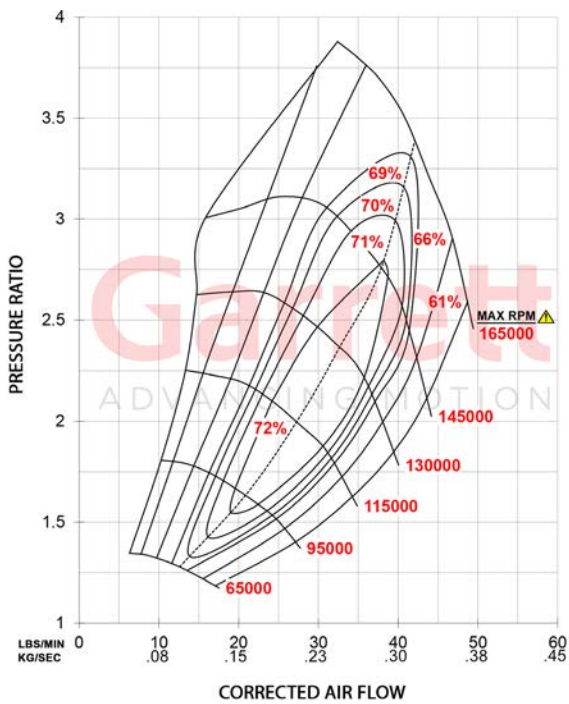

FEATURES:

- ◆ GEN 2 AERODYNAMICS FEATURE INCREASED HORSEPOWER RANGE
- ◆ IMPROVED PORTED SHROUD DESIGN FOR SURGE RESISTANCE
- ◆ FULLY-MACHINED SPEED SENSOR PORT. DETAILS ON PG. 80
- ◆ WASTEGATE ACTUATORS & BRACKET KIT AVAILABLE ON PG. 81

EXHAUST FLOW CHART

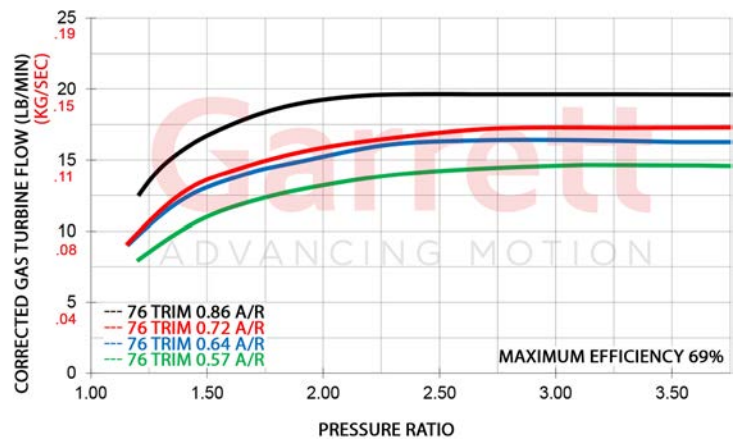

GTX2867R Gen II		Compressor				Turbine		
		Inducer	Exducer	Trim	A/R	Inducer	Exducer	Trim
HP: 275-550	Disp: 1.4L-2.5L	50mm	67mm	55	0.60	54mm	47mm	76
Supercore	Assembly Kit	Turbine Kit		A/R	Inlet	Outlet	Wastegate	Divided
849894-5002S	856800-5005S	827690-0001		0.57	V-Band	V-Band	Free Float	N
	856800-5006S	827690-0002		0.72	V-Band	V-Band	Free Float	N
Assembly Kit PN Includes	856800-5007S	827690-0003		0.64	T25	5 bolt	Wastegated	N
Supercore and Turbine Kit	856800-5008S	827690-0004		0.86	T25	5 bolt	Wastegated	N

Garrett GTX3071R GEN II

Horsepower: 340 - 675
Displacement: 1.8L - 3.0L

Garrett
ADVANCING MOTION

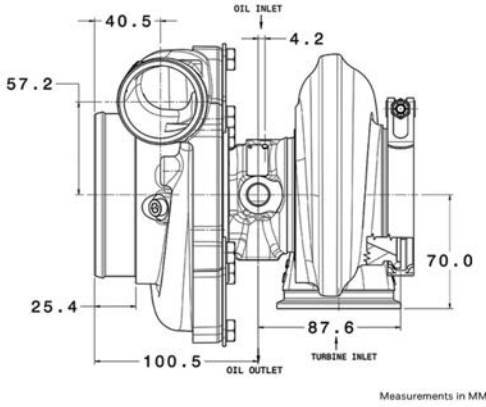

COMPRESSOR MAP

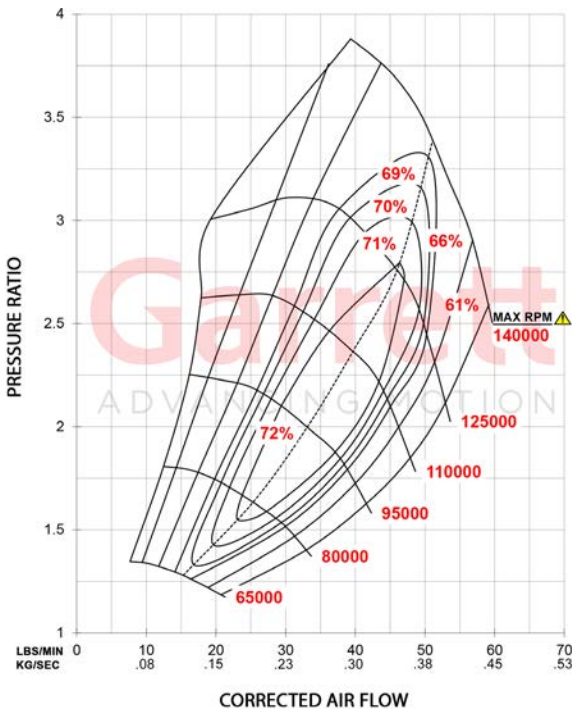

FEATURES:

- ◆ GEN 2 AERODYNAMICS FEATURE INCREASED HORSEPOWER RANGE
- ◆ FULLY-MACHINED SPEED SENSOR PORT. DETAILS ON PG. 80
- ◆ WASTEGATE ACTUATORS & BRACKET KIT AVAILABLE ON PG. 81
- ◆ REVERSE ROTATION CONFIGURATIONS AVAILABLE

EXHAUST FLOW CHART

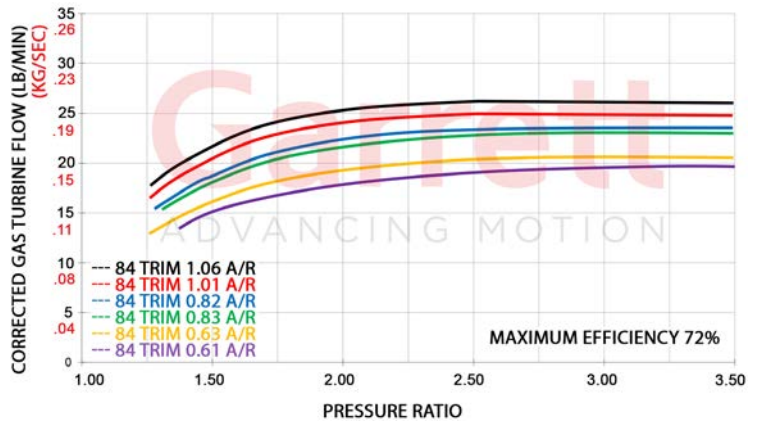

GTX3071R Gen II		Compressor				Turbine		
HP: 340-675	Disp: 1.8L-3.0L	Inducer	Exducer	Trim	A/R	Inducer	Exducer	Trim
Supercore	Assembly Kit	54mm	71mm	58	0.60	60mm	55mm	84
851154-5002S	856801-5006S	Turbine Kit		A/R	Inlet	Outlet	Wastegate	Divided
	856801-5005S	740902-0009		0.63	T3	V-Band	Free Float	N
		740902-0008		0.82	T3	V-Band	Free Float	N
		740902-0007		1.06	T3	V-Band	Free Float	N
	856801-5018S	740902-0036		0.61	V-Band	V-Band	Free Float	N
	856801-5017S	740902-0035		0.83	V-Band	V-Band	Free Float	N
		740902-0034		1.01	V-Band	V-Band	Free Float	N
		771300-0006		0.63	T3	5 bolt	Wastegated	N
Assembly Kit PN Includes		771300-0005		0.82	T3	5 bolt	Wastegated	N
Supercore and Turbine Kit		771300-0004		1.06	T3	5 bolt	Wastegated	N
Reverse Rotation	Supercore	Turbine Kit		A/R	Inlet	Outlet	Wastegate	Divided
	844621-5003S	740902-0053		0.61	V-Band	V-Band	Free Float	N
		740902-0054		0.83	V-Band	V-Band	Free Float	N
		740902-0055		1.01	V-Band	V-Band	Free Float	N

Garrett GTX3076R GEN II

Horsepower: 400 - 750
Displacement: 1.8L - 3.0L

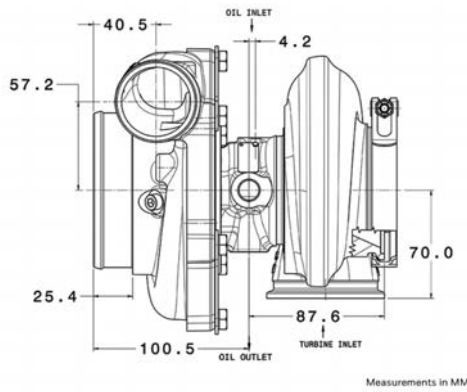

COMPRESSOR MAP

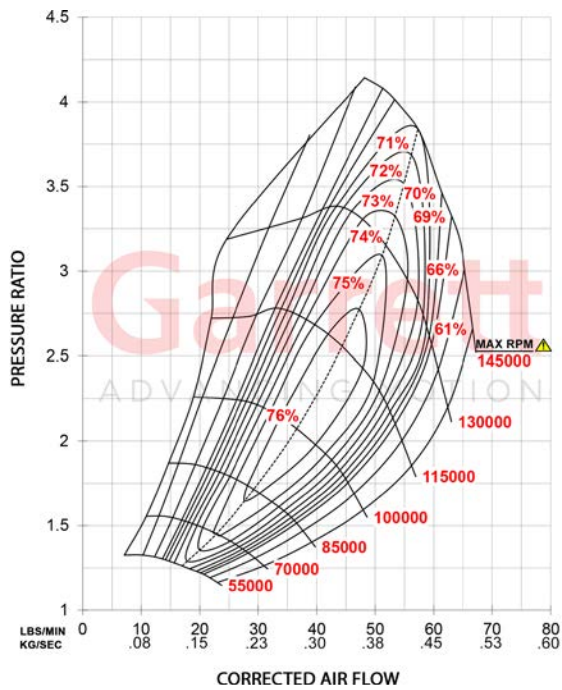

FEATURES:

- ◆ GEN 2 AERODYNAMICS FEATURE INCREASED HORSEPOWER RANGE
- ◆ FULLY-MACHINED SPEED SENSOR PORT. DETAILS ON PG. 80
- ◆ WASTEGATE ACTUATORS & BRACKET KIT AVAILABLE ON PG. 81
- ◆ REVERSE ROTATION OPTIONS AVAILABLE

EXHAUST FLOW CHART

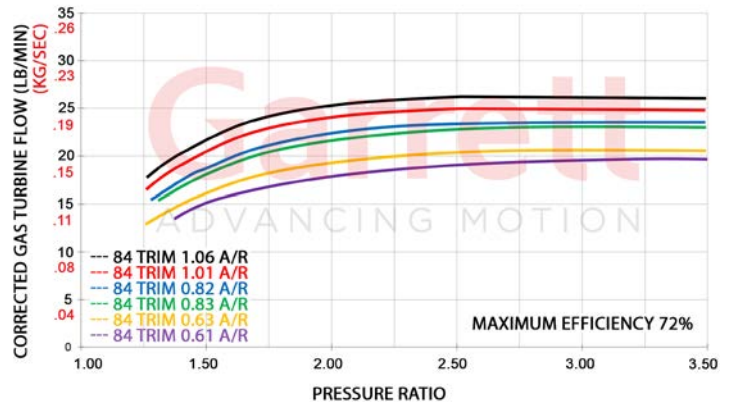

GTX3076R Gen II		Compressor				Turbine			
		Inducer	Exducer	Trim	A/R	Inducer	Exducer	Trim	
HP: 400-750	Disp: 1.8L-3.0L	58mm	76mm	58	0.60	60mm	55mm	84	
Supercore	Assembly Kit	Turbine Kit			A/R	Inlet	Outlet	Wastegate	Divided
851154-5001S	856801-5027S	740902-0009			0.63	T3	V-Band	Free Float	N
	856801-5026S	740902-0008			0.82	T3	V-Band	Free Float	N
		740902-0007			1.06	T3	V-Band	Free Float	N
		740902-0036			0.61	V-Band	V-Band	Free Float	N
	856801-5038S	740902-0035			0.83	V-Band	V-Band	Free Float	N
	856801-5037S	740902-0034			1.01	V-Band	V-Band	Free Float	N
			771300-0006			0.63	T3	5 bolt	Wastegated
Assembly Kit PN Includes Supercore and Turbine Kit		771300-0005			0.82	T3	5 bolt	Wastegated	N
		771300-0004			1.06	T3	5 bolt	Wastegated	N
Reverse Rotation	Supercore	Turbine Kit			A/R	Inlet	Outlet	Wastegate	Divided
	844621-5004S	740902-0053			0.61	V-Band	V-Band	Free Float	N
		740902-0054			0.83	V-Band	V-Band	Free Float	N
		740902-0055			1.01	V-Band	V-Band	Free Float	N

Garrett GTX3576R GEN II

Horsepower: 400 - 750
Displacement: 2.0L- 4.5L

Garrett
ADVANCING MOTION

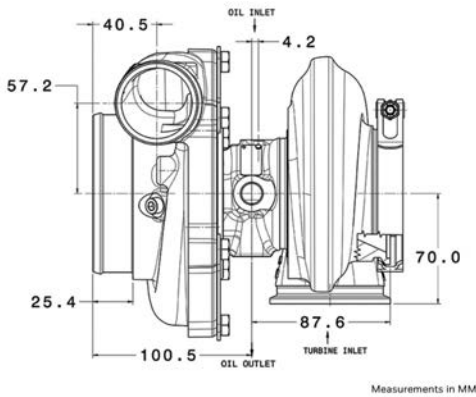

COMPRESSOR MAP

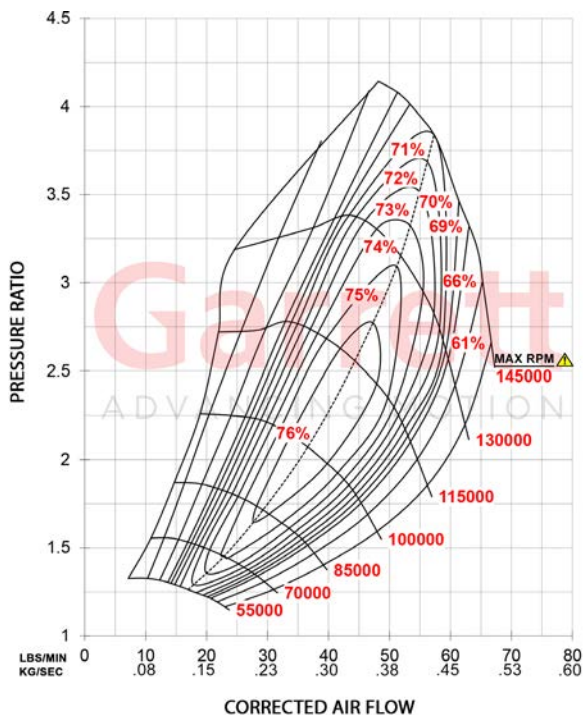

FEATURES:

- ◆ GEN 2 AERODYNAMICS FEATURE INCREASED HORSEPOWER RANGE
- ◆ FULLY-MACHINED SPEED SENSOR PORT. DETAILS ON PG. 80
- ◆ REVERSE ROTATION OPTIONS AVAILABLE

EXHAUST FLOW CHART

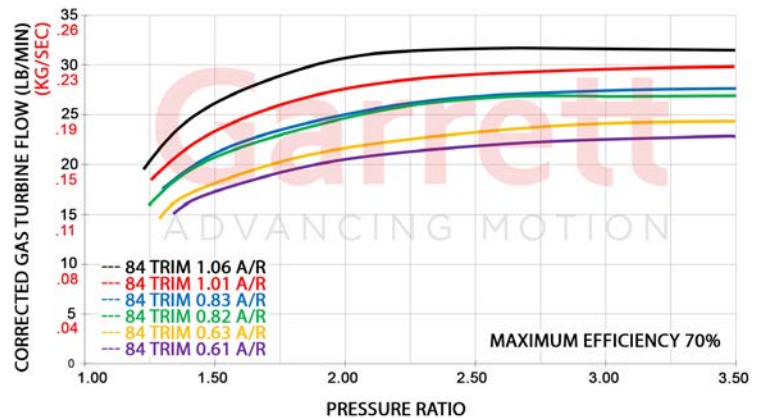

GTX3576R Gen II		Compressor				Turbine		
		Inducer	Exducer	Trim	A/R	Inducer	Exducer	Trim
HP: 400-750	Disp: 2.0L-4.5L	58mm	76mm	58	0.60	68mm	62mm	84
Supercore	Assembly Kit	Turbine Kit			Inlet	Outlet	Wastegate	Divided
851154-5003S		740902-0012		0.63	T3	V-Band	Free Float	N
		740902-0011		0.82	T3	V-Band	Free Float	N
		740902-0010		1.06	T3	V-Band	Free Float	N
		740902-0018		0.63	T4	V-Band	Free Float	N
		740902-0017		0.82	T4	V-Band	Free Float	N
		740902-0016		1.06	T4	V-Band	Free Float	N
Assembly Kit PN Includes Supercore and Turbine Kit	856801-5059S	740902-0033		0.61	V-Band	V-Band	Free Float	N
	856801-5059S	740902-0032		0.83	V-Band	V-Band	Free Float	N
	856801-5058S	740902-0031		1.01	V-Band	V-Band	Free Float	N
Reverse Rotation	Supercore	Turbine Kit			Inlet	Outlet	Wastegate	Divided
	844626-5003S	740902-0056		0.61	V-Band	V-Band	Free Float	N
		740902-0057		0.83	V-Band	V-Band	Free Float	N
		740902-0058		1.01	V-Band	V-Band	Free Float	N

Garrett GTX3582R GEN II

Horsepower: 450 - 900
Displacement: 2.0L - 4.5L

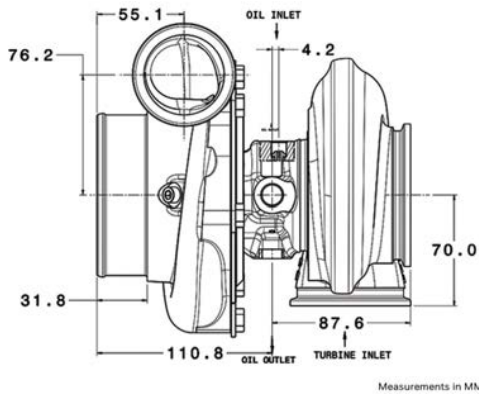

REVERSE ROTATION

COMPRESSOR MAP

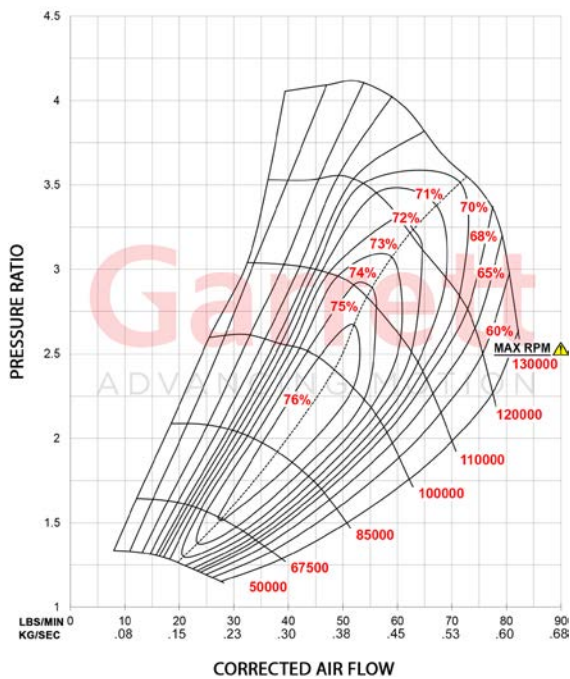

FEATURES:

- ◆ GEN 2 AERODYNAMICS FEATURE INCREASED HORSEPOWER RANGE
- ◆ FULLY-MACHINED SPEED SENSOR PORT. DETAILS ON PG. 80
- ◆ REVERSE ROTATION OPTIONS AVAILABLE

EXHAUST FLOW CHART

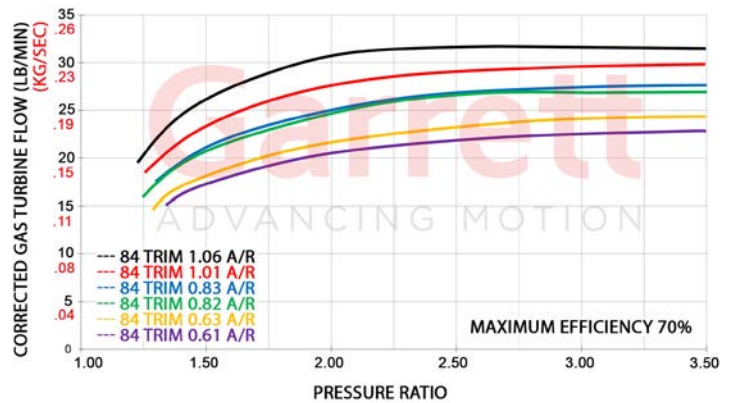

GTX3582R Gen II		Compressor				Turbine		
		Inducer	Exducer	Trim	A/R	Inducer	Exducer	Trim
HP: 450-900	Disp: 2.0L-4.5L	66mm	82mm	64	0.70	68mm	62mm	84
Supercore	Assembly Kit	Turbine Kit		A/R	Inlet	Outlet	Wastegate	Divided
851154-5004S	856801-5068S	740902-0012		0.63	T3	V-Band	Free Float	N
		740902-0011		0.82	T3	V-Band	Free Float	N
		740902-0010		1.06	T3	V-Band	Free Float	N
	856801-5071S	740902-0018		0.63	T4	V-Band	Free Float	N
		740902-0017		0.82	T4	V-Band	Free Float	N
		740902-0016		1.06	T4	V-Band	Free Float	N
740902-0033		0.61	V-Band	V-Band	Free Float	N		
Assembly Kit PN Includes Supercore and Turbine Kit	856801-5080S	740902-0032		0.83	V-Band	V-Band	Free Float	N
	856801-5079S	740902-0031		1.01	V-Band	V-Band	Free Float	N
Reverse Rotation	Supercore	Turbine Kit		A/R	Inlet	Outlet	Wastegate	Divided
	844626-5004S	740902-0056		0.61	V-Band	V-Band	Free Float	N
		740902-0057		0.83	V-Band	V-Band	Free Float	N
740902-0058		1.01	V-Band	V-Band	Free Float	N		

Garrett GTX3584RS

Horsepower: 550 - 1000
Displacement: 2.0L - 5.5L

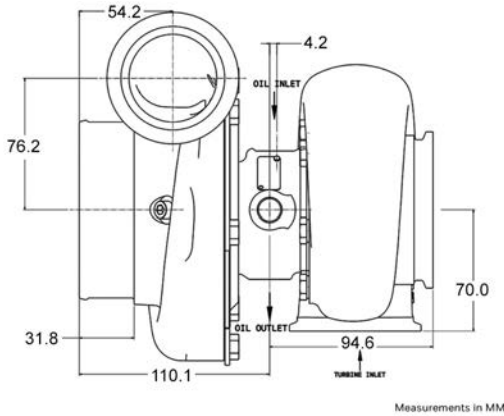

COMPRESSOR MAP

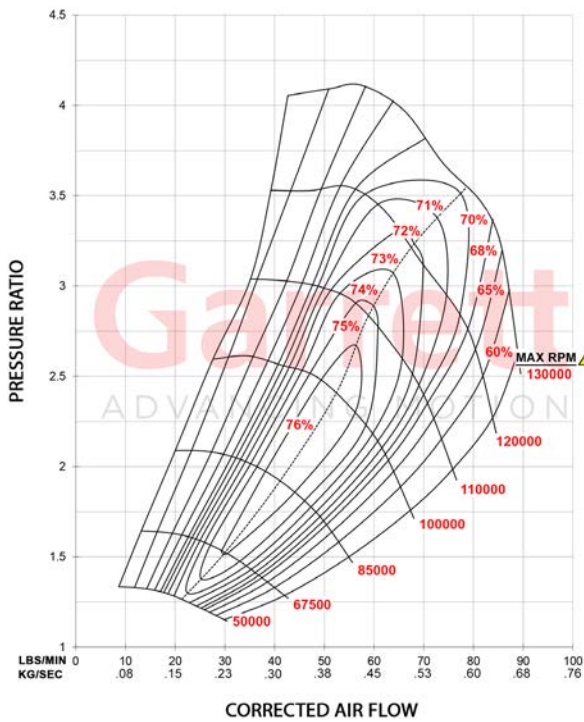

FEATURES:

- ◆ GEN 2 AERODYNAMICS FEATURE INCREASED HORSEPOWER RANGE
- ◆ "RS" HIGH FLOWING TURBINE WHEEL
- ◆ COMPACT DESIGN FOR TIGHT INSTALLATIONS
- ◆ FULLY-MACHINED SPEED SENSOR PORT. DETAILS ON PG. 80
- ◆ COMP OUTLET AVAILABLE IN V-BAND & HOSE CONNECTION

EXHAUST FLOW CHART

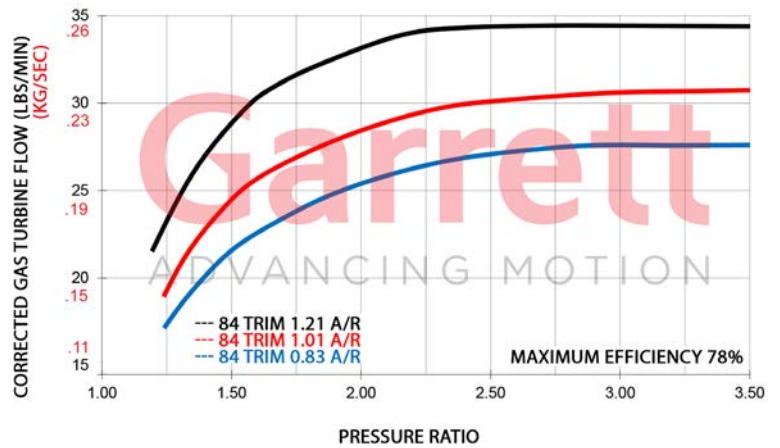

GTX3584RS		Compressor				Turbine		
		Inducer	Exducer	Trim	A/R	Inducer	Exducer	Trim
HP: 550-1000	Disp: 2.0L-5.5L	67mm	84mm	64	0.72	68mm	62mm	84
Supercore	Assembly Kit	Turbine Kit		A/R	Inlet	Outlet	Wastegate	Divided
846098-5001S	856804-5001S	740902-0067		0.83	V-Band	V-Band	Free Float	N
Hose bead comp outlet	856804-5002S	740902-0066		1.01	V-Band	V-Band	Free Float	N
		740902-0052		1.21	V-Band	V-Band	Free Float	N
846098-5002S		740902-0067		0.83	V-Band	V-Band	Free Float	N
V-band comp outlet		740902-0066		1.01	V-Band	V-Band	Free Float	N
		740902-0052		1.21	V-Band	V-Band	Free Float	N

*GTX3584 turbine housings not compatible with GT/GTX35 housings

Garrett GTX4088R

Horsepower: 460 - 850
Displacement: 2.0L - 6.0L

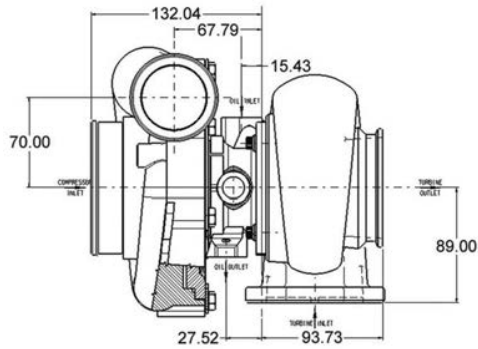

Measurements in MM



COMPRESSOR MAP

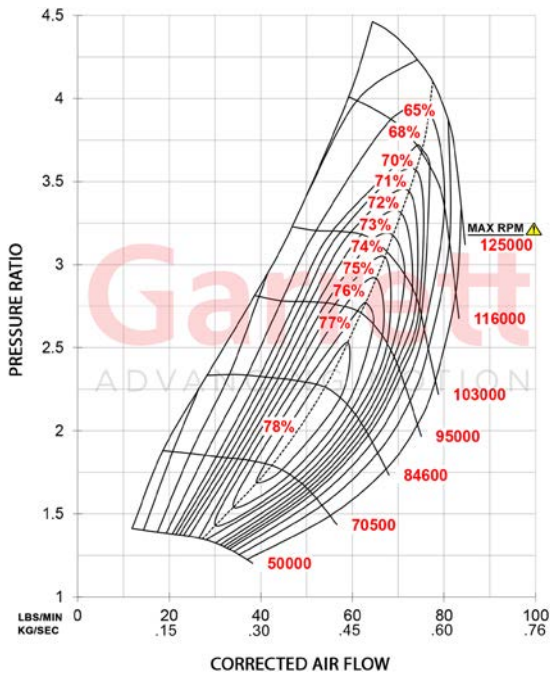

FEATURES:

- ◆ FEATURES ORIGINAL GTX COMP WHEEL AERODYNAMICS
- ◆ SUPERCORE AND TURBINE KIT SOLD SEPARATELY
- ◆ AVAILABLE ONLY WITH DIVIDED TURBINE HOUSINGS

EXHAUST FLOW CHART

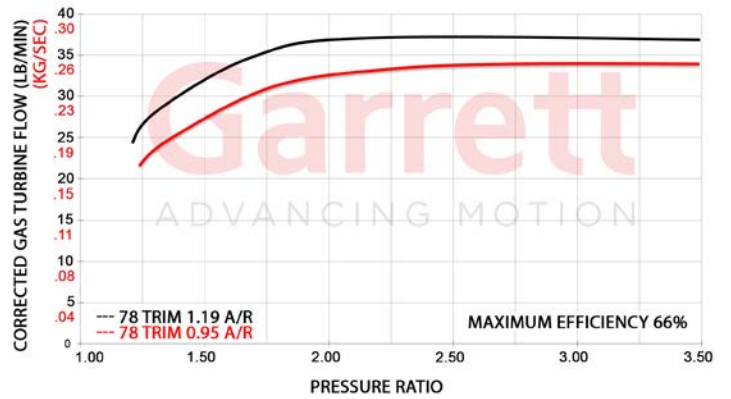

GTX4088R		Compressor				Turbine		
		Inducer	Exducer	Trim	A/R	Inducer	Exducer	Trim
HP: 460-850	Disp: 2.0L-6.0L	65mm	88mm	54	0.72	77mm	68mm	78
Supercore		PN						
Standard Rotation		825614-5005S						
Turbine Kits: GTX40		PN		A/R	Inlet	Outlet	Wastegate	Divided
Free Float		773628-0011		0.95	T4	V-Band	External	Y
		773628-0013		1.19	T4	V-Band	External	Y

Garrett GTX4294R

Horsepower: 475 - 950
Displacement: 2.0L - 7.0L

Garrett
ADVANCING MOTION

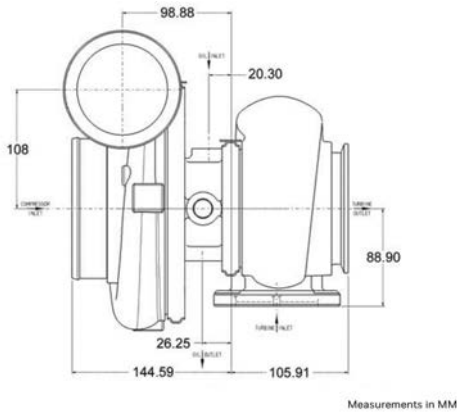

COMPRESSOR MAP

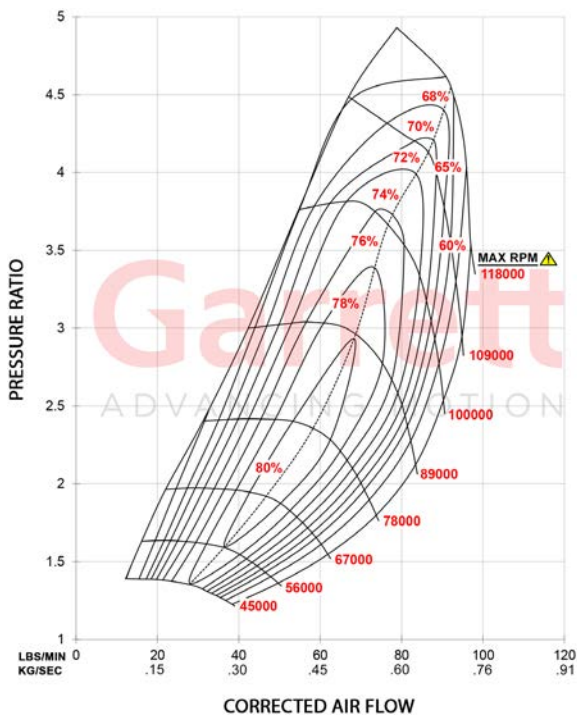

FEATURES:

- ◆ FEATURES ORIGINAL GTX COMP WHEEL AERODYNAMICS
- ◆ SUPERCORE AND TURBINE KIT SOLD SEPARATELY
- ◆ AVAILABLE ONLY WITH DIVIDED TURBINE HOUSINGS
- ◆ V-BAND COMPRESSOR OUTLET CONFIGURATION

EXHAUST FLOW CHART

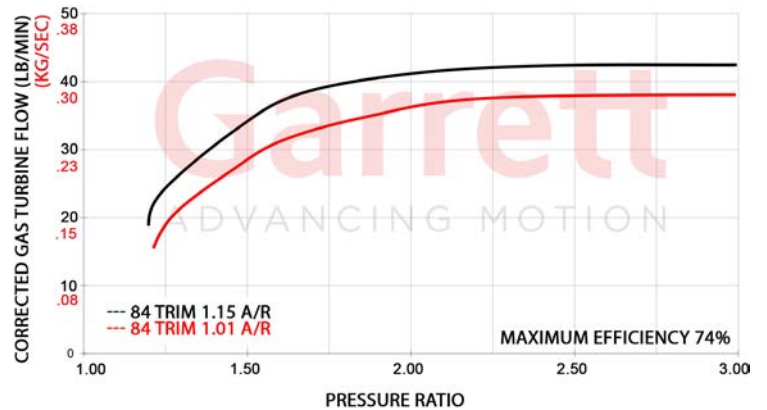

GTX4294R		Compressor				Turbine		
HP: 475-950	Disp: 2.0L-7.0L	Inducer	Exducer	Trim	A/R	Inducer	Exducer	Trim
Supercore		70mm	94mm	56	0.60	82mm	75mm	84
Standard Rotation		PN 800269-5001S						
Turbine Kits: GTX42		PN	A/R	Inlet	Outlet	Wastegate	Divided	
Free Float		757707-0002	1.15	T4	V-Band	External	Y	
		757707-0003	1.28	T4	V-Band	External	Y	
		757707-0004	1.44	T4	V-Band	External	Y	

Garrett GTX4202R

Horsepower: 525 - 1120
Displacement: 2.0L - 7.0L

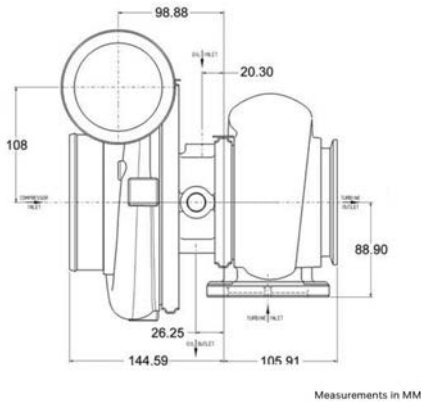

COMPRESSOR MAP

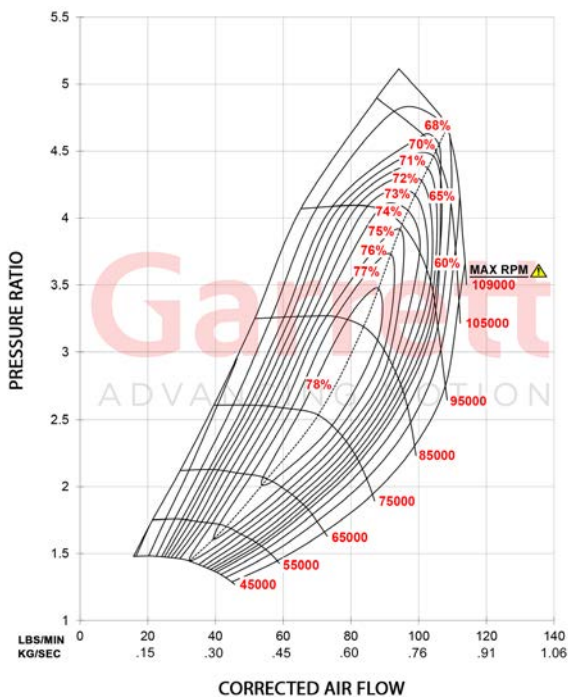

FEATURES:

- ◆ FEATURES ORIGINAL GTX COMP WHEEL AERODYNAMICS
- ◆ SUPERCORE AND TURBINE KIT SOLD SEPARATELY
- ◆ AVAILABLE ONLY WITH DIVIDED TURBINE HOUSINGS
- ◆ V-BAND COMPRESSOR OUTLET CONFIGURATION

EXHAUST FLOW CHART

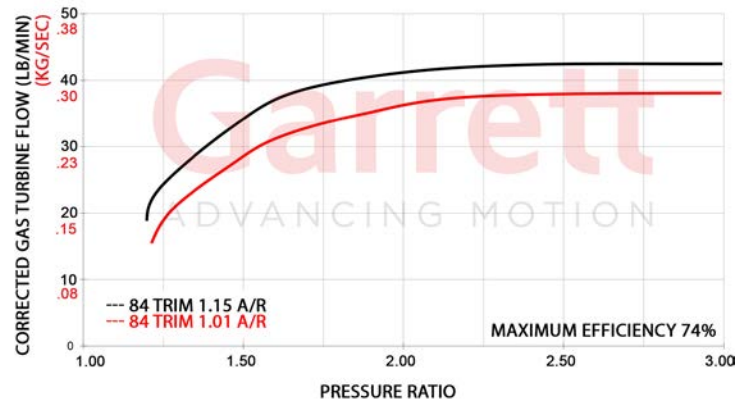

GTX4202R		Inducer	Exducer	Trim	A/R	Inducer	Exducer	Trim
HP: 525-1120	Disp: 2.0L-7.0L	76mm	102mm	55	0.60	82mm	75mm	84
Supercore		PN						
Standard Rotation		800269-5002S						
Turbine Kits: GTX42		PN		A/R	Inlet	Outlet	Wastegate	Divided
Free Float		757707-0002		1.15	T4	V-Band	External	Y
		757707-0003		1.28	T4	V-Band	External	Y
		757707-0004		1.44	T4	V-Band	External	Y

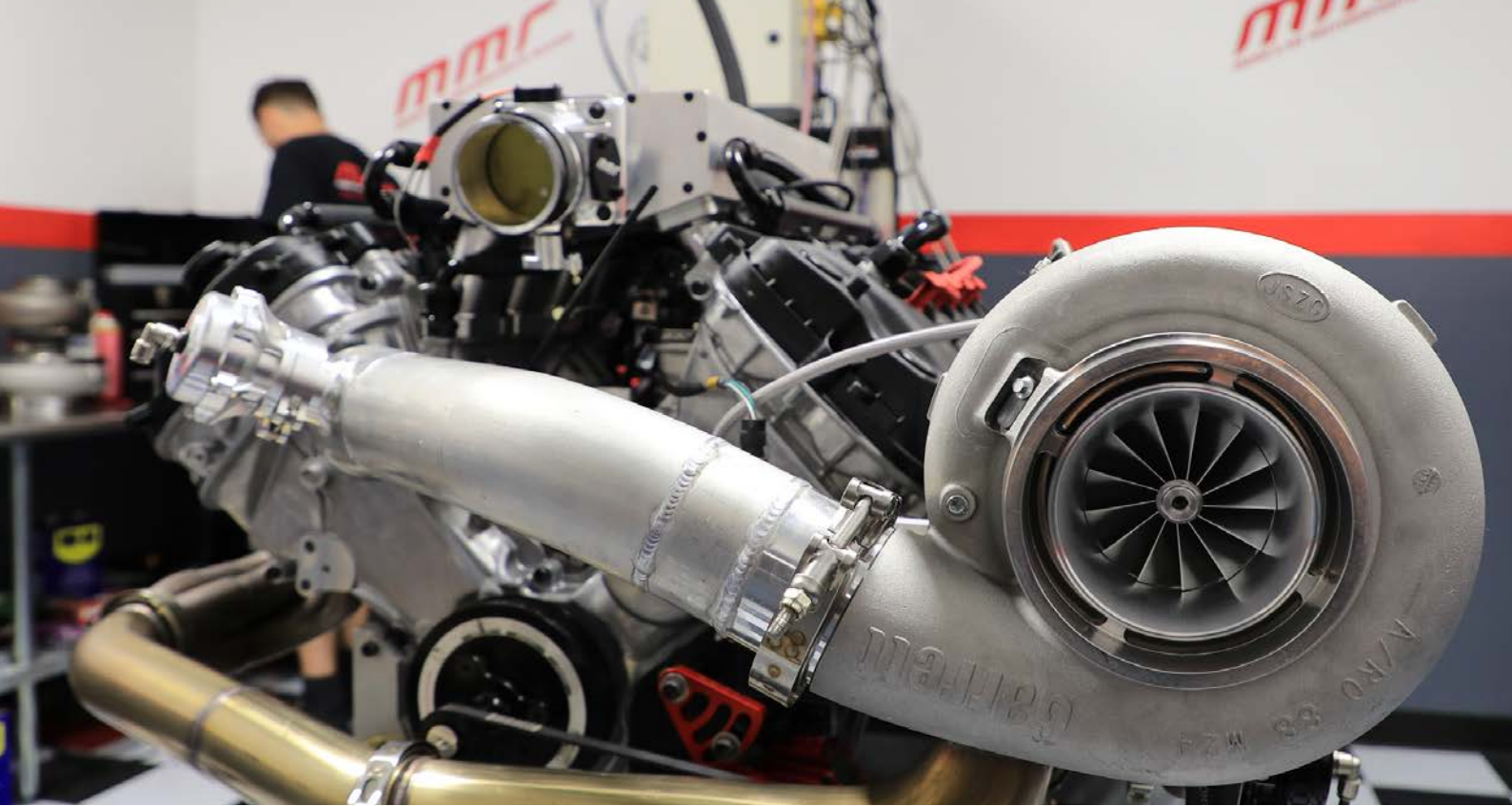

Mark Luton (left) and Greg Seth-Hunter (right) inside the MMR dynocell. The Superflow dyno allows them to test components for performance gains without having to take the racecar to the track.



The turbochargers tested are the GTX5020R Gen II 76mm, 80mm, 88mm, and the GTX5533R Gen II 94mm. Tuning is performed by Mark Luton using Fuel Tech software.

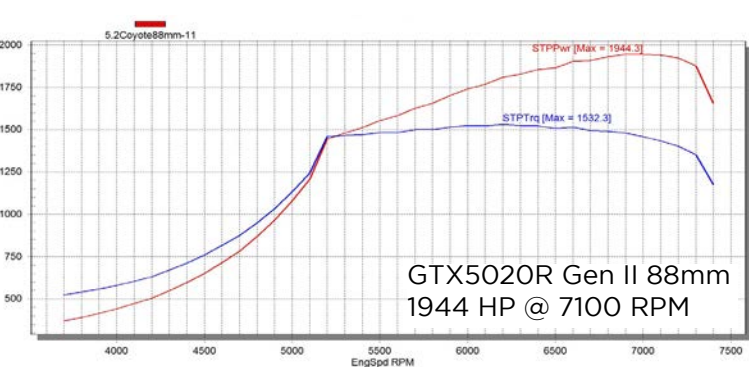

Mark Luton (left) and Greg Seth-Hunter (right) inside the MMR dynocell. The Superflow dyno allows them to test components for performance gains without having to take the racecar to the track.

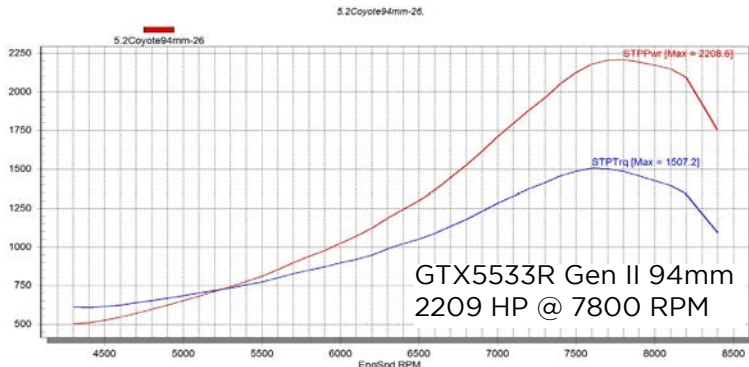

Mark Luton (left) and Greg Seth-Hunter (right) inside the MMR dynocell. The Superflow dyno allows them to test components for performance gains without having to take the racecar to the track.

Garrett GTX4709R GEN II

Horsepower: 825 - 1625
Displacement: 2.0L - 10.0L

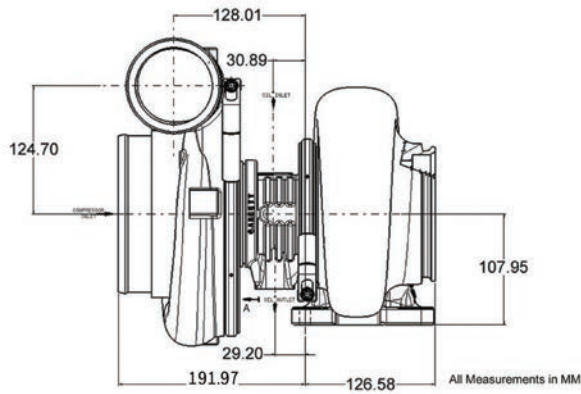

COMPRESSOR MAP

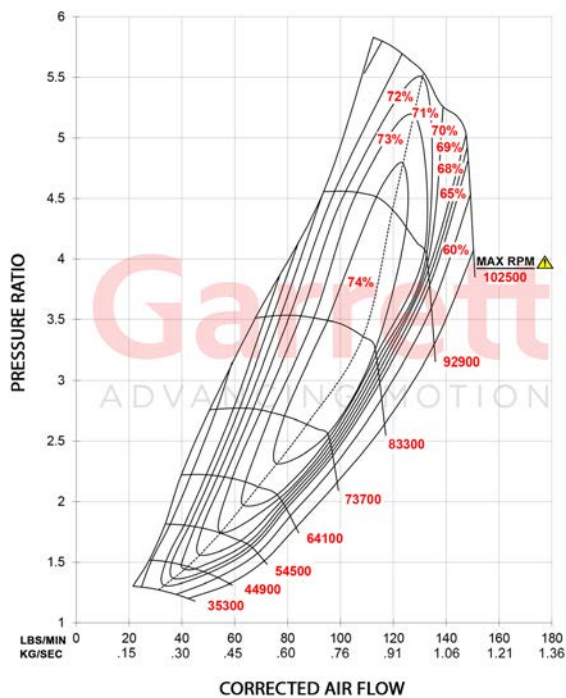

FEATURES:

- ◆ GEN 2 COMPRESSOR WHEEL AERODYNAMICS
- ◆ 15% INCREASED COMPRESSOR FLOW
- ◆ 76MM, 80MM, INDUCER CONFIGURATIONS
- ◆ .88 A/R COMPRESSOR HOUSING VOLUTE
- ◆ 39% LOWER INERTIA THAN PREVIOUS GENERATION
- ◆ SUPERCORE AND TURBINE HOUSING SOLD SEPARATELY
- ◆ COMPATIBLE WITH GT AND GTX GEN I TURBINE HOUSINGS

EXHAUST FLOW CHART

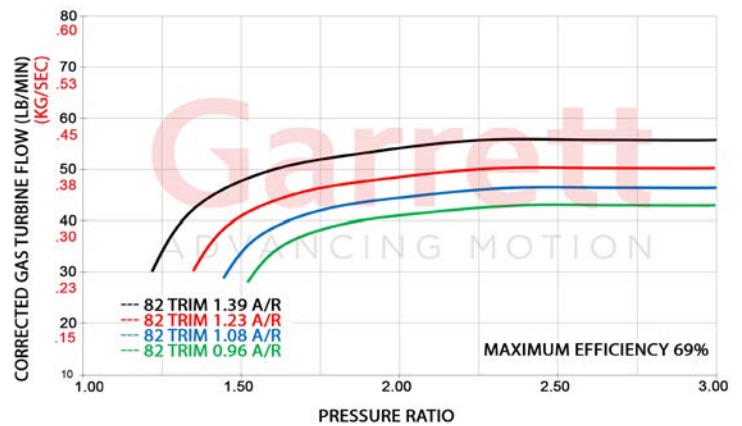

GTX4709R Gen II		Compressor				Turbine		
HP: 825-1625	Disp: 2.0L-10.0L	Inducer	Exducer	Trim	A/R	Inducer	Exducer	Trim
Supercore	PN							
	851285-5011S	76mm	109mm	49	0.88	93mm	84mm	82
	851285-5012S	80mm	109mm	54	0.88	93mm	84mm	82
Turbine Kits: GTX47		PN			A/R	Inlet	Outlet	Wastegate
Free Float		761208-0010			1.08	T6	V-Band	External
		761208-0011			1.23	T6	V-Band	External

Garrett GTX4720R GEN II

Horsepower: 1025 - 1950
Displacement: 2.5L - 10.0L

Garrett
ADVANCING MOTION

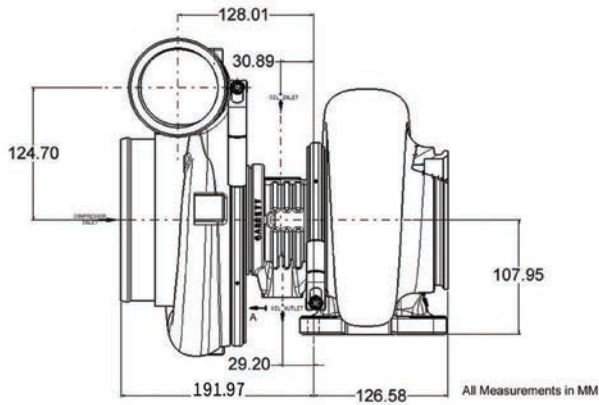

COMPRESSOR MAP

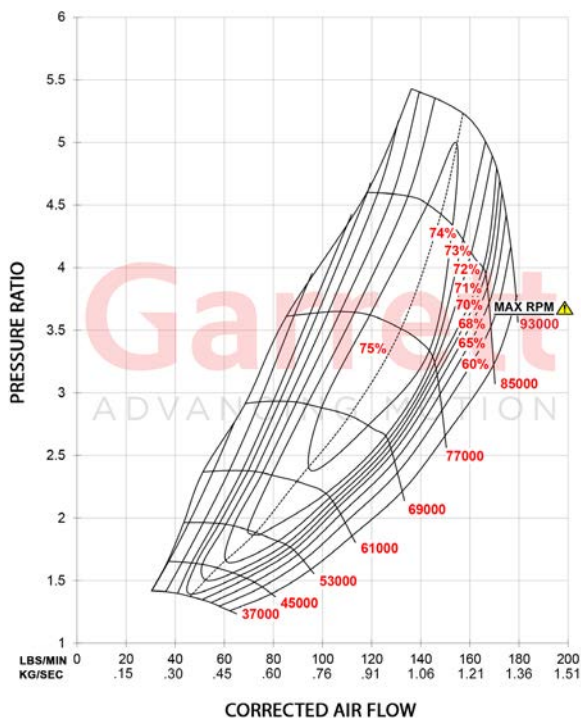

FEATURES:

- ◆ GEN 2 COMPRESSOR WHEEL AERODYNAMICS
- ◆ 9% INCREASED COMPRESSOR FLOW
- ◆ 76MM, 80MM, 88MM INDUCER CONFIGURATIONS
- ◆ .88 A/R COMPRESSOR HOUSING VOLUTE
- ◆ 30% LOWER INERTIA THAN PREVIOUS GENERATION
- ◆ SUPERCORE AND TURBINE HOUSING SOLD SEPARATELY
- ◆ COMPATIBLE WITH GT AND GTX GEN I TURBINE HOUSINGS

EXHAUST FLOW CHART

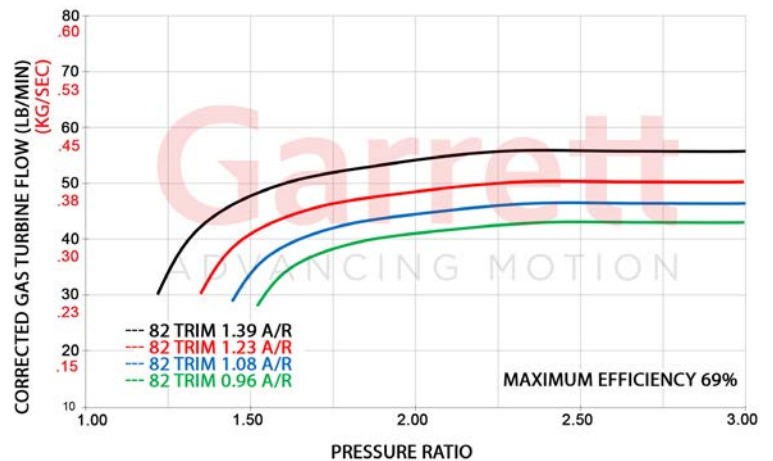

GTX4720R Gen II		Compressor				Turbine		
HP: 1025-1950	Disp: 2.5L-10.0L	Inducer	Exducer	Trim	A/R	Inducer	Exducer	Trim
Supercore PN								
	851285-5013S	76mm	120mm	41	0.88	93mm	84mm	82
	851285-5014S	80mm	120mm	45	0.88	93mm	84mm	82
	851285-5015S	88mm	120mm	54	0.88	93mm	84mm	82
Turbine Kits: GTX47		PN		A/R	Inlet	Outlet	Wastegate	Divided
Free Float		761208-0010		1.08	T6	V-Band	External	N
		761208-0011		1.23	T6	V-Band	External	N

Garrett GTX5009R GEN II

Horsepower: 875 - 1700
Displacement: 2.5L - 10.0L

Garrett
ADVANCING MOTION

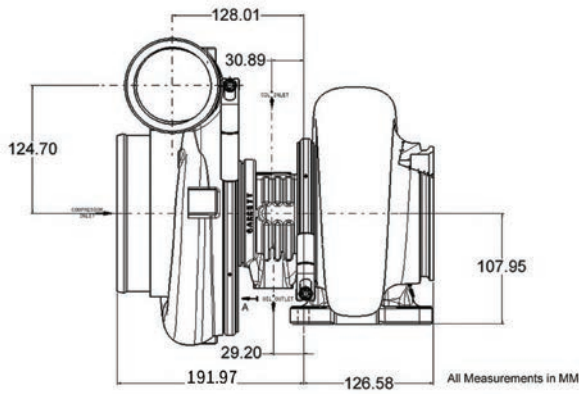

COMPRESSOR MAP

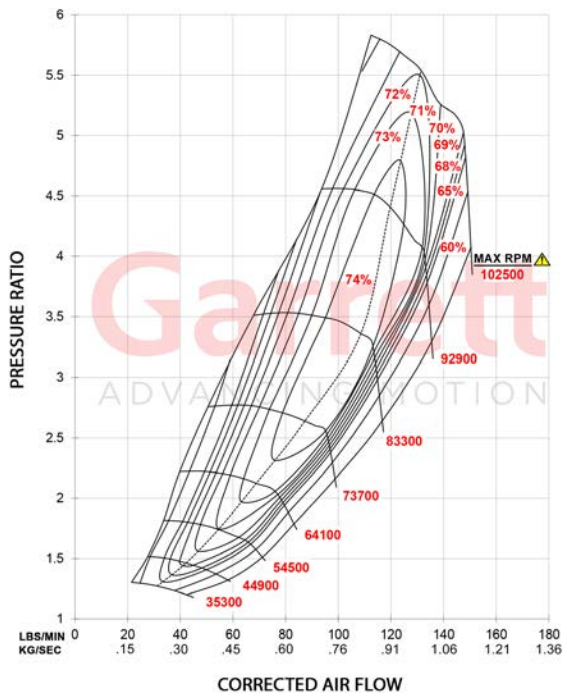

FEATURES:

- ◆ GEN 2 COMPRESSOR WHEEL AERODYNAMICS
- ◆ 15% INCREASED COMPRESSOR FLOW
- ◆ 76MM, 80MM, INDUCER CONFIGURATIONS
- ◆ .88 A/R COMPRESSOR HOUSING VOLUTE
- ◆ 39% LOWER INERTIA THAN PREVIOUS GENERATION
- ◆ SUPERCORE AND TURBINE HOUSING SOLD SEPARATELY
- ◆ COMPATIBLE WITH GT AND GTX GEN I TURBINE HOUSINGS

EXHAUST FLOW CHART

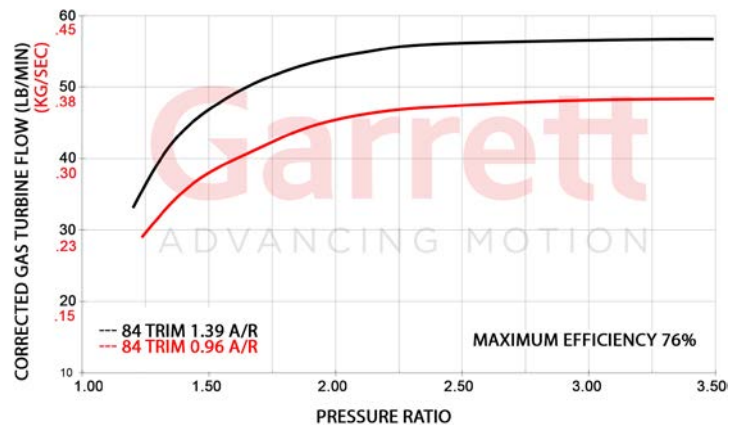

GTX5009R Gen II		Compressor				Turbine		
HP: 875-1700	Disp: 2.5L-10.0L	Inducer	Exducer	Trim	A/R	Inducer	Exducer	Trim
Supercore	PN							
	851285-5016S	76mm	109mm	49	0.88	99mm	91mm	84
	851285-5017S	80mm	109mm	54	0.88	99mm	91mm	84
Turbine Kits: GTX50	PN			A/R	Inlet	Outlet	Wastegate	Divided
Free Float	761208-0030			0.96	T6	V-Band	External	N
	761208-0032			1.23	T6	V-Band	External	N
	761208-0033			1.39	T6	V-Band	External	N

Garrett GTX5020R GEN II

Horsepower: 1075 - 2050
Displacement: 2.8L - 11.0L

Garrett
ADVANCING MOTION

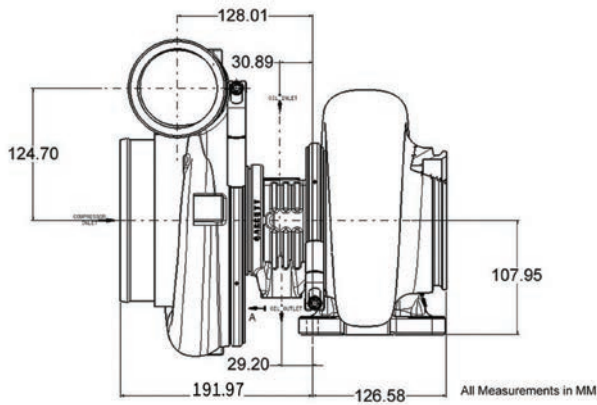

COMPRESSOR MAP

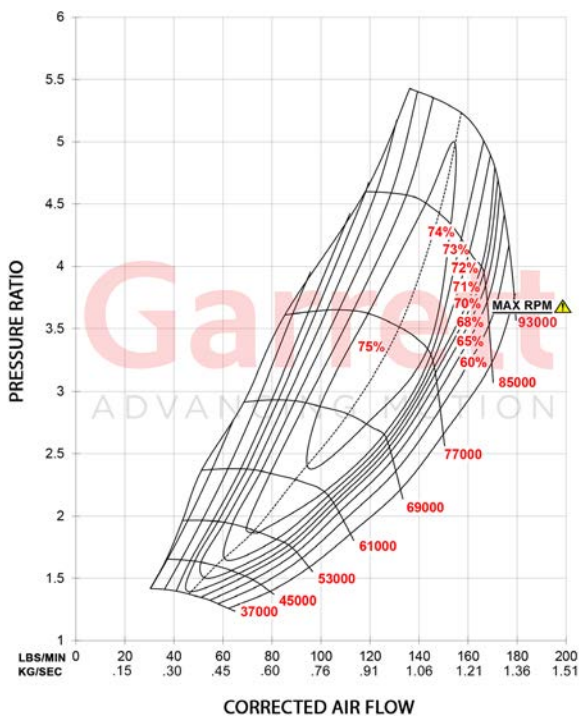

FEATURES:

- ◆ GEN 2 COMPRESSOR WHEEL AERODYNAMICS
- ◆ 9% INCREASED COMPRESSOR FLOW
- ◆ 76MM, 80MM, 88MM INDUCER CONFIGURATIONS
- ◆ .88 A/R COMPRESSOR HOUSING VOLUTE
- ◆ 30% LOWER INERTIA THAN PREVIOUS GENERATION
- ◆ SUPERCORE AND TURBINE HOUSING SOLD SEPARATELY
- ◆ COMPATIBLE WITH GT AND GTX GEN I TURBINE HOUSINGS

EXHAUST FLOW CHART

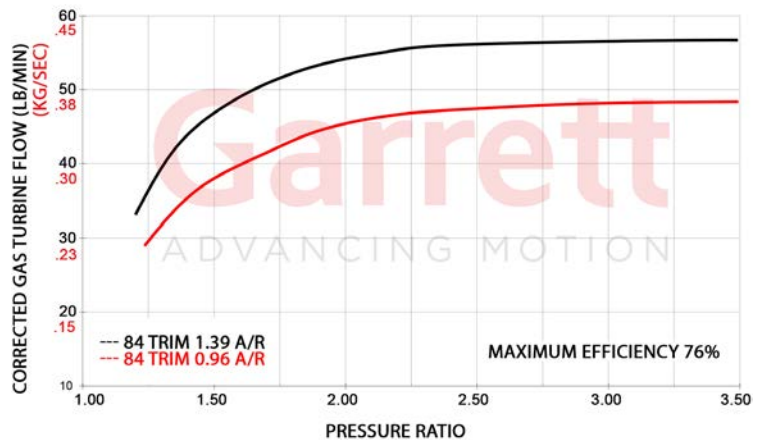

GTX5020R Gen II		Compressor				Turbine				
HP: 1075-2050	Disp: 2.8L-11.0L	Inducer	Exducer	Trim	A/R	Inducer	Exducer	Trim		
Supercore		PN				Inducer	Exducer	Trim		
		851285-5018S	76mm	120mm	41	0.88	99mm	91mm	84	
		851285-5019S	80mm	120mm	45	0.88	99mm	91mm	84	
		851285-5020S	88mm	120mm	54	0.88	99mm	91mm	84	
Turbine Kits: GTX50		PN				A/R	Inlet	Outlet	Wastegate	Divided
Free Float		761208-0030			0.96	T6	V-Band	External	N	
		761208-0032			1.23	T6	V-Band	External	N	
		761208-0033			1.39	T6	V-Band	External	N	

Garrett GTX5533R GEN II



Horsepower: 1000- 2500
Displacement: 3.0L - 12.0L

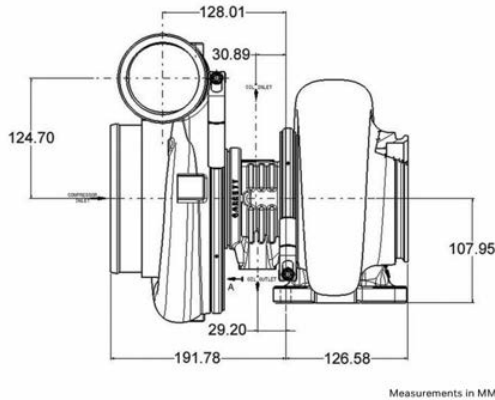

COMPRESSOR MAP

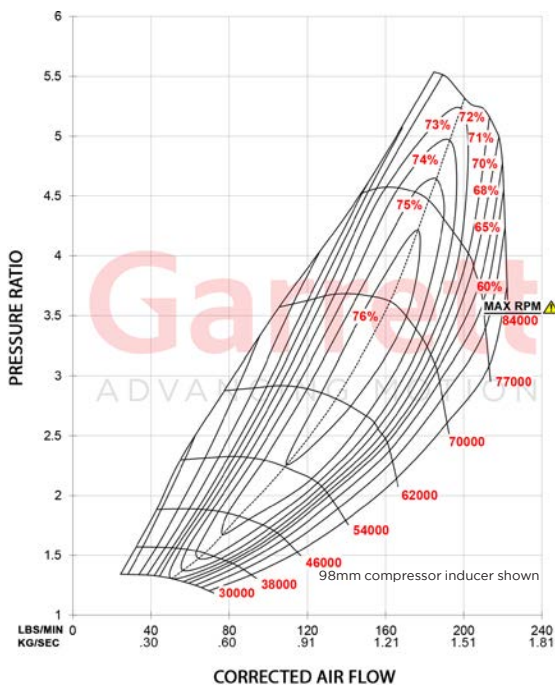

FEATURES:

- ◆ GEN 2 AERODYNAMICS FEATURE INCREASED HORSEPOWER RANGE
- ◆ NEW FULLY-MACHINED SPEED SENSOR PORT
- ◆ IMPROVED PORTED SHROUD DESIGN FOR SURGE RESISTANCE
- ◆ LIGHTWEIGHT BILLET BACKPLATE
- ◆ V-BAND COMPRESSOR OUTLET CONFIGURATION
- ◆ T6 AND V-BAND TURBINE HOUSING INLET OPTIONS

EXHAUST FLOW CHART

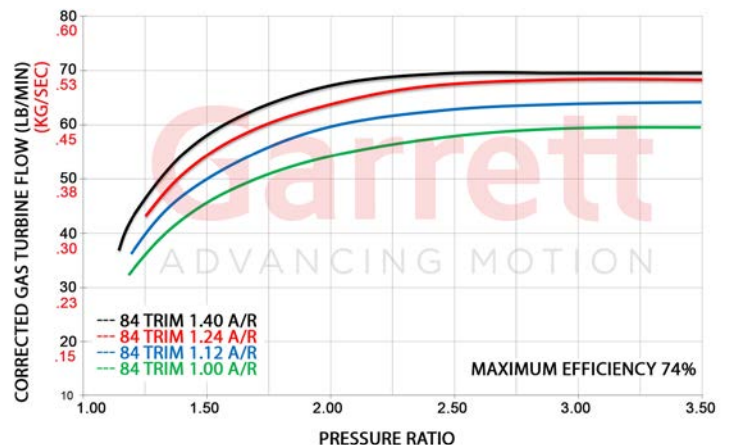

GTX5533R Gen II		Compressor				Turbine		
HP:1000-2500	Disp: 3.0L-12.0L	Inducer	Exducer	Trim	A/R	Inducer	Exducer	Trim
Supercore	PN							
	851285-5001S	85mm	133mm	41	0.88	112mm	102mm	84
	851285-5002S	88mm	133mm	44	0.88	112mm	102mm	84
	851285-5003S	91mm	133mm	47	0.96	112mm	102mm	84
	851285-5004S	94mm	133mm	50	0.96	112mm	102mm	84
	851285-5005S	98mm	133mm	54	0.96	112mm	102mm	84
Turbine Kits: GTX55		PN		A/R	Inlet	Outlet	Wastegate	Divided
* Long outlet with cross bolts		*761208-0062		1.24	V-Band	V-Band	External	N
		*761208-0063		1.40	V-Band	V-Band	External	N
		761208-0064		1.24	V-Band	V-Band	External	N
		761208-0065		1.40	V-Band	V-Band	External	N
		761208-0015		1.12	T6	V-Band	External	N
		761208-0025		1.24	T6	V-Band	External	N
		761208-0017		1.40	T6	V-Band	External	N

Garrett GTX5544R GEN II

Horsepower: 1400- 2850
Displacement: 3.0L - 12.0L

Garrett
ADVANCING MOTION

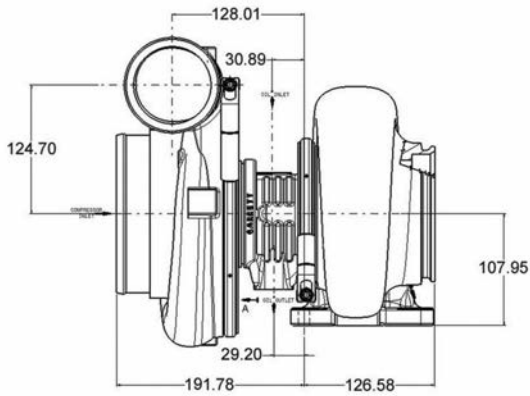

Measurements in MM



COMPRESSOR MAP

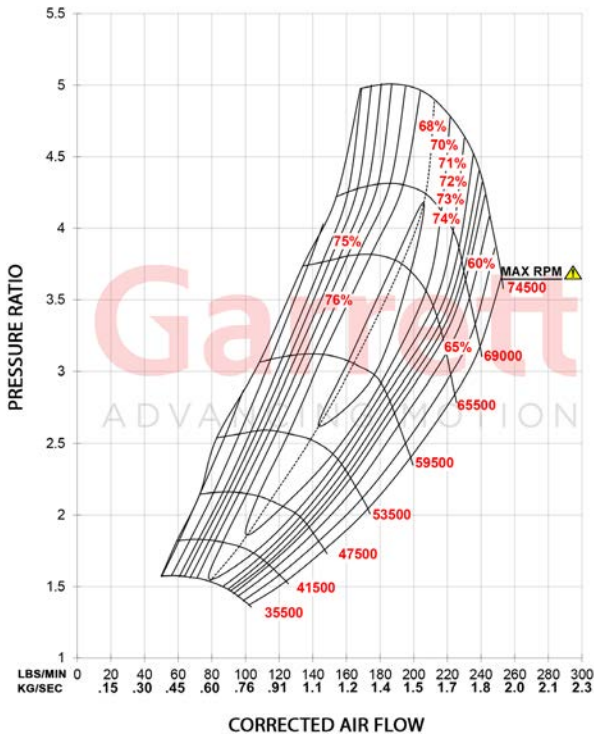

FEATURES:

- ◆ GEN 2 COMPRESSOR WHEEL AERODYNAMICS
- ◆ LIGHTWEIGHT BILLET BACKPLATE
- ◆ (NEW) BACKPLATE TO COMPRESSOR HOUSING O-RING
- ◆ 144MM COMPRESSOR EXDUCER
- ◆ FEATURES THE .96 A/R COMPRESSOR HOUSING
- ◆ SUPERCORE AND TURBINE HOUSING SOLD SEPARATELY
- ◆ COMPATIBLE WITH GT, GTX, AND GTX5533R TURBINE HOUSINGS

EXHAUST FLOW CHART

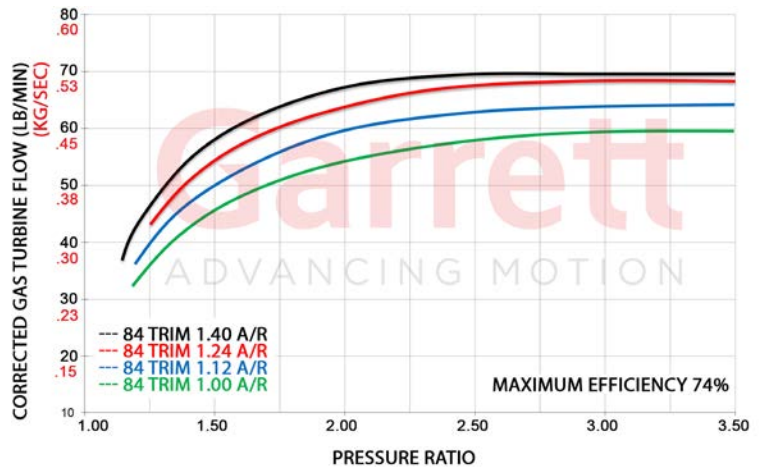

GTX5544R Gen II		Compressor				Turbine		
HP:1400-2850	Disp: 3.0L-12.0L	Inducer	Exducer	Trim	A/R	Inducer	Exducer	Trim
Supercore		PN						
851285-5021S		102mm	144mm	50	0.96	112mm	102mm	84
851285-5022S		106mm	144mm	54	0.96	112mm	102mm	84
Turbine Kits: GTX55		PN		A/R	Inlet	Outlet	Wastegate	Divided
* Long outlet with cross bolts		*761208-0062		1.24	V-Band	V-Band	External	N
		*761208-0063		1.40	V-Band	V-Band	External	N
		761208-0064		1.24	V-Band	V-Band	External	N
		761208-0065		1.40	V-Band	V-Band	External	N
		761208-0015		1.12	T6	V-Band	External	N
		761208-0025		1.24	T6	V-Band	External	N
		761208-0017		1.40	T6	V-Band	External	N



GTX5533R GEN II

Horsepower: 1000- 2500
 Displacement: 3.0L - 12.0L
 Comp: 85mm, 88mm, 91mm, 94mm, 98mm



GTX5544R GEN II

Horsepower: 1400- 2850
 Displacement: 3.0L - 12.0L
 Comp: 102mm, 106mm

FEATURES:

- ◆ GEN II AERODYNAMICS FEATURE INCREASED HORSEPOWER RANGE
- ◆ NEW FULLY MACHINED SPEED SENSOR PORT
- ◆ IMPROVED PORTED SHROUD DESIGN FOR SURGE RESISTANCE
- ◆ LIGHTWEIGHT BILLET BACKPLATE
- ◆ V-BAND COMPRESSOR OUTLET CONFIGURATION
- ◆ AVAILABLE IN 85MM, 88MM, 91MM, 94MM, 98MM, 102MM, 106MM

GTX55 STAINLESS STEEL TURBINE HOUSING CONFIGURATIONS



FEATURES:

- ◆ 1.24 A/R AND 1.40 A/R OPTIONS
- ◆ 3/8" GRADE 5 CROSS BOLTS ON LONG OUTLET HOUSINGS
- ◆ THREADED BOSSES FOR ATTACHMENT POINTS
- ◆ 4.25" V-BAND INLET | 5" V-BAND OUTLET
- ◆ COMPATIBLE WITH GTX5533R GEN I & GEN II | GTX5544R
- ◆ LONG AND SHORT OUTLET CONFIGURATIONS

GTX55 Turbine Kit PN	Desc	A/R	Inlet	Outlet
761208-0062	Long Outlet	1.24	V-Band	V-Band
761208-0064	Short Outlet	1.24	V-Band	V-Band
761208-0063	Long Outlet	1.40	V-Band	V-Band
761208-0065	Short Outlet	1.40	V-Band	V-Band

GARRETT BOOST | CLUB LINE

Garrett Boost | Club Line turbochargers are high performance journal bearing products at a cost effective price range. GBC combines modern, high flowing aerodynamics with a robust journal bearing rotating group to make a powerful and affordable turbocharger.



THE REPLACEMENT FOR **SMALL** DISPLACEMENT



Product Features	GBC14-200	GBC17-250	GBC20-300	GBC22-350	GBC35-700	GBC37-900
Displacement Range	0.4L-1.0L	0.6L-1.5L	0.8L-2.0L	1.0L-2.5L	2.0L-5.0L	2.0L-5.5L
Horsepower Range	140-200	150-250	170-300	200-350	400-700	450-900
Standard Rotation	•	•	•	•	•	•
Internally Wastegated	•	•	•	•		
Aluminum Backplate					•	•
Oil Cooled	•	•	•	•	•	•
Journal Bearing	•	•	•	•	•	•
Machined Pressure Port	•	•	•	•	•	•
Ported Shroud					•	•
T25 Inlet Turbine Housing		•	•	•		
T3 Inlet Turbine Housing					•	•
T4 Inlet Turbine Housing					•	•
T4 Divided Inlet Turbine Housing					•	•
3-Bolt Inlet Turbine Housing	•					
Inconel Turbine Wheel	•	•	•	•	•	•
Outline Interchangeable		•	•	•		
Outline Interchangeable					•	•

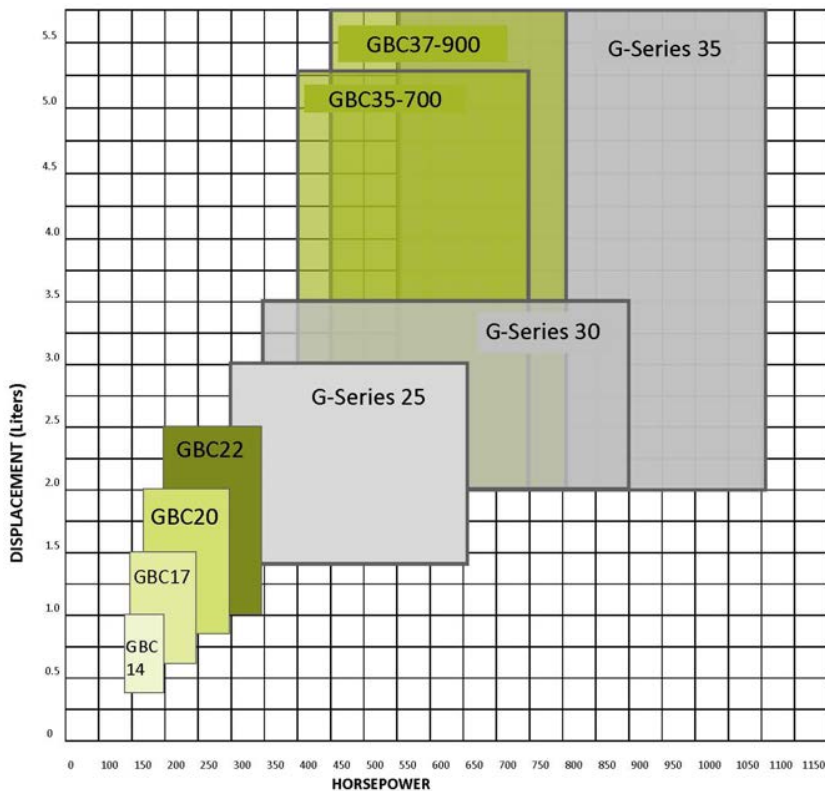

GARRETT BOOST | CLUB LINE FEATURES

- FRAME SIZES => 14, 17, 20, 22, 35, 37
- GBC (17|20|22) & (35|37) ARE OUTLINE INTERCHANGEABLE
- 150 - 900 HORSEPOWER CAPABILITY
- INTEGRATED WASTEGATE ASSEMBLY WITH CALIBRATED ACTUATOR (14|17|20|22)
- BILLET COMPRESSOR WHEEL WITH EXTENDED TIP DESIGN FOR HIGHER PRESSURE RATIO CAPABILITY
- GTX GEN II COMPRESSOR AERODYNAMICS
- MODERN TURBINE WHEEL AERODYNAMICS
- INCONEL TURBINE WHEEL MATERIAL
- DUCTILE IRON (SIMO+) TURBINE HOUSING MATERIAL
- JOURNAL BEARING ROTATING GROUP WITH 360-DEGREE THRUST BEARING
- OIL-COOLED CENTER HOUSING
- MACHINED BOOST SIGNAL PORT WITH INSTALLED PLUG

Garrett GBC14-200

Horsepower: 140 - 200
 Displacement: 0.4L - 1.0L

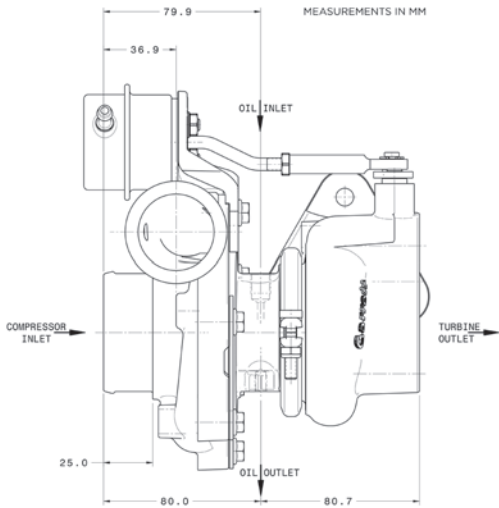

COMPRESSOR MAP

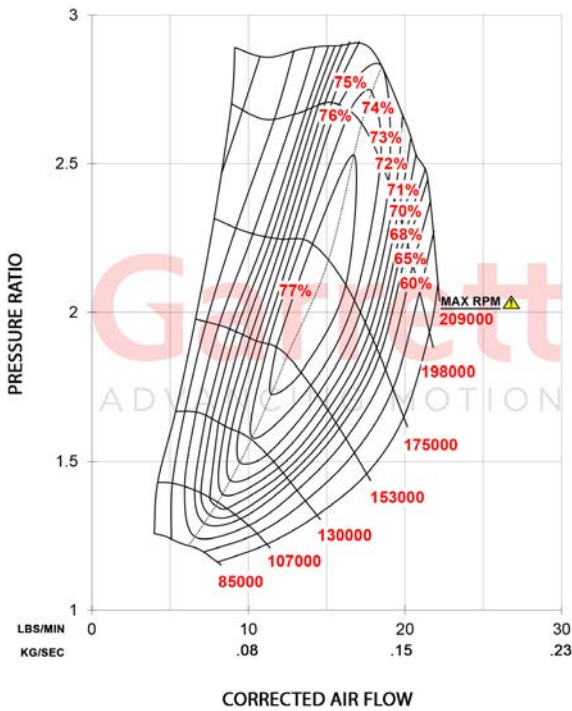

FEATURES:

- ◆ 34MM COMPRESSOR INDUCER
- ◆ SUPPORTS UP TO 200 HORSEPOWER
- ◆ FORGED FULLY-MACHINED COMPRESSOR WHEEL
- ◆ JOURNAL BEARING ROTATING GROUP
- ◆ INTERNALLY WASTEGATED TURBINE HOUSING
- ◆ ENGINEERED FOR SMALL DISPLACEMENT ENGINES INCLUDING POWERSPORTS, PERSONAL WATERCRAFT AND AUTOMOBILES

EXHAUST FLOW CHART

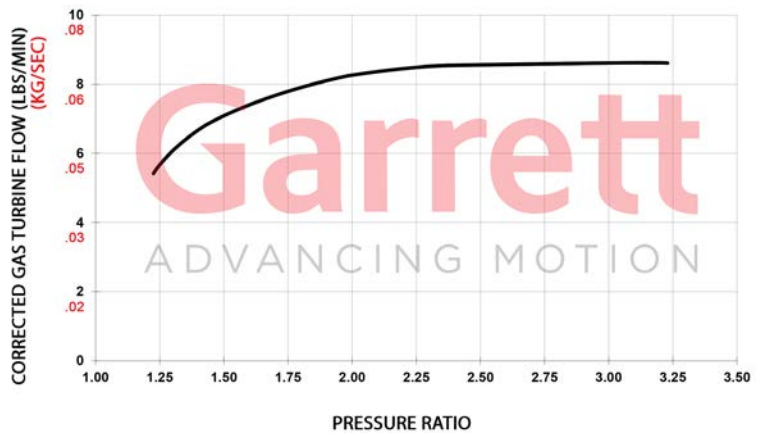

GBC14-200		Compressor			Turbine			
HP: 140-200	Disp: 0.4L-1.0L	Inducer	Exducer	A/R	Inducer	Exducer	Trim	A/R
Turbo PN: 896051-5004S		34mm	46mm	0.52	39mm	36mm	84	0.45

Garrett GBC17-250

Horsepower: 150 - 250
Displacement: 0.6L - 1.5L

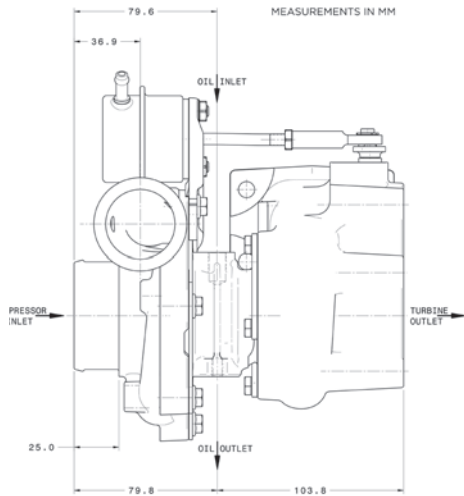

COMPRESSOR MAP

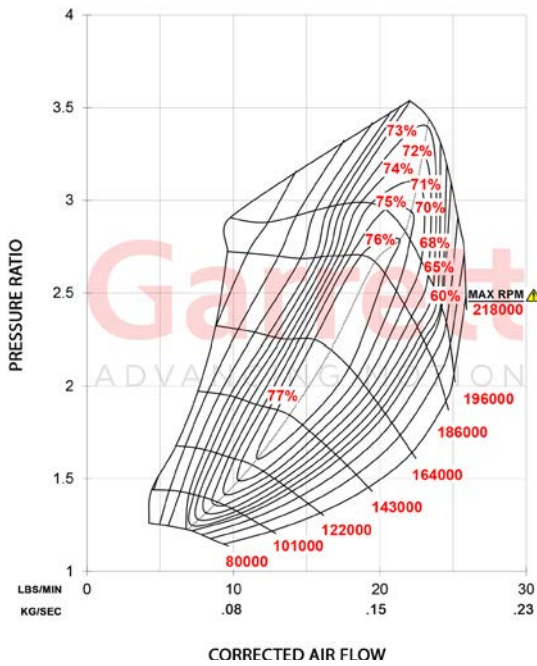

FEATURES:

- ◆ 36MM COMPRESSOR INDUCER
- ◆ SUPPORTS UP TO 250 HORSEPOWER
- ◆ FORGED FULLY-MACHINED COMPRESSOR WHEEL
- ◆ JOURNAL BEARING ROTATING GROUP
- ◆ INTERNALLY WASTEGATED TURBINE HOUSING
- ◆ ENGINEERED FOR SMALL DISPLACEMENT ENGINES INCLUDING POWERSPORTS, PERSONAL WATERCRAFT AND AUTOMOBILES

EXHAUST FLOW CHART

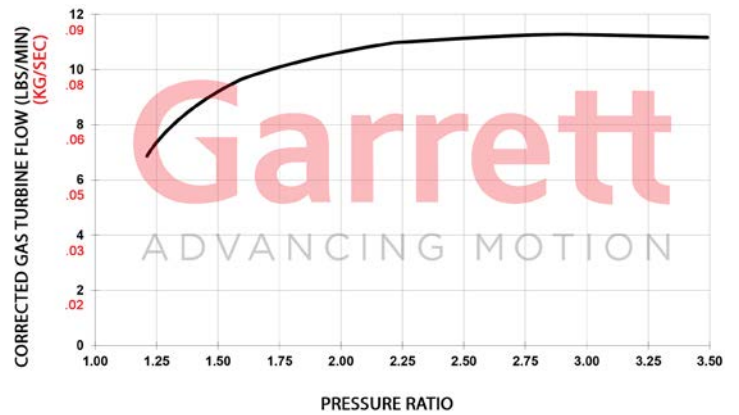

GBC17-250		Compressor			Turbine			
HP: 150-250	Disp: 0.6L-1.5L	Inducer	Exducer	A/R	Inducer	Exducer	Trim	A/R
Turbo PN: 896052-5003S		36mm	49mm	0.52	44mm	40mm	80	0.5

Garrett GBC20-300

Horsepower: 170 - 300
Displacement: 0.8L - 2.0L

Garrett
ADVANCING MOTION

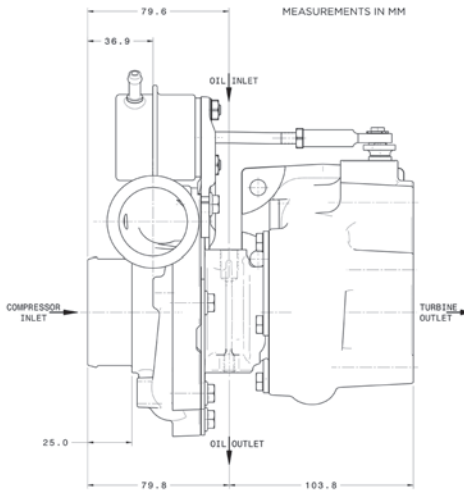

COMPRESSOR MAP

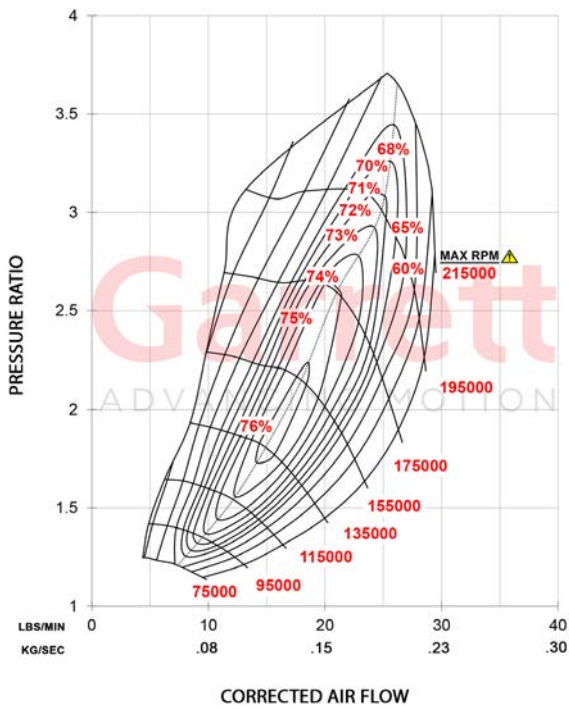

FEATURES:

- ◆ 39MM COMPRESSOR INDUCER
- ◆ SUPPORTS UP TO 300 HORSEPOWER
- ◆ FORGED FULLY-MACHINED COMPRESSOR WHEEL
- ◆ JOURNAL BEARING ROTATING GROUP
- ◆ INTERNALLY WASTEGATED TURBINE HOUSING
- ◆ ENGINEERED FOR SMALL DISPLACEMENT ENGINES INCLUDING POWERSPORTS, PERSONAL WATERCRAFT AND AUTOMOBILES

EXHAUST FLOW CHART

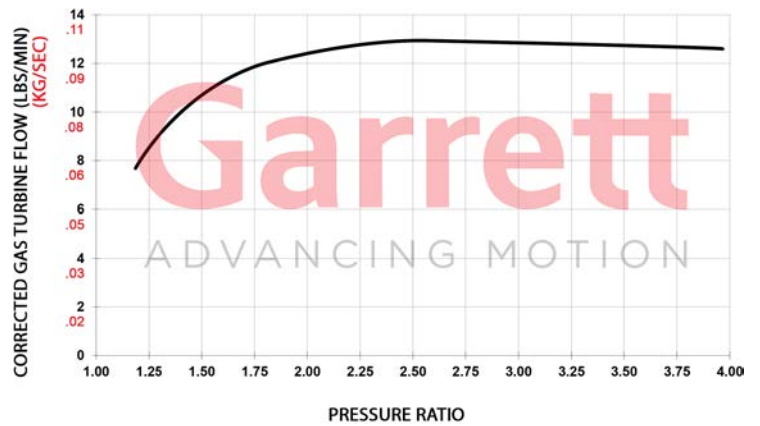

GBC20-300		Compressor			Turbine			
HP: 170-300	Disp: 0.8L-2.0L	Inducer	Exducer	A/R	Inducer	Exducer	Trim	A/R
Turbo PN: 896053-5003S		39mm	52mm	0.59	47mm	42mm	84	0.55

Garrett GBC22-350

Horsepower: 200 - 350
 Displacement: 1.0L - 2.5L

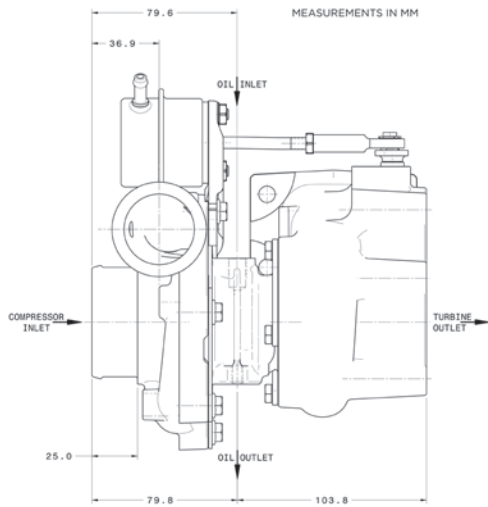

COMPRESSOR MAP

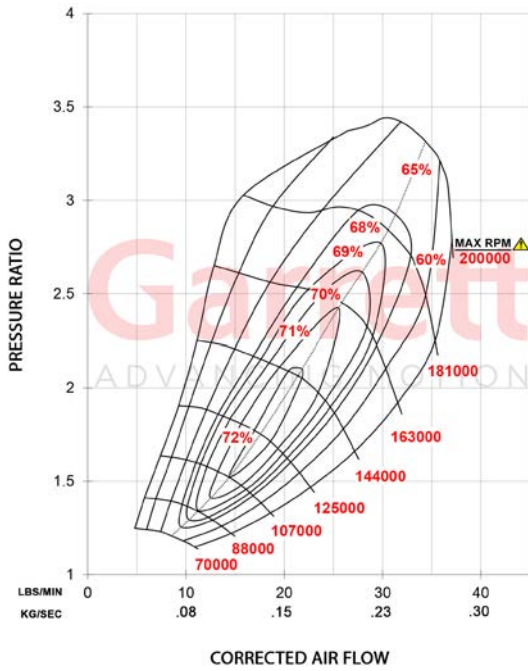

FEATURES:

- ◆ 44MM COMPRESSOR INDUCER
- ◆ SUPPORTS UP TO 350 HORSEPOWER
- ◆ FORGED FULLY-MACHINED COMPRESSOR WHEEL
- ◆ JOURNAL BEARING ROTATING GROUP
- ◆ INTERNALLY WASTEGATED TURBINE HOUSING
- ◆ ENGINEERED FOR SMALL DISPLACEMENT ENGINES INCLUDING POWERSPORTS, PERSONAL WATERCRAFT AND AUTOMOBILES

EXHAUST FLOW CHART

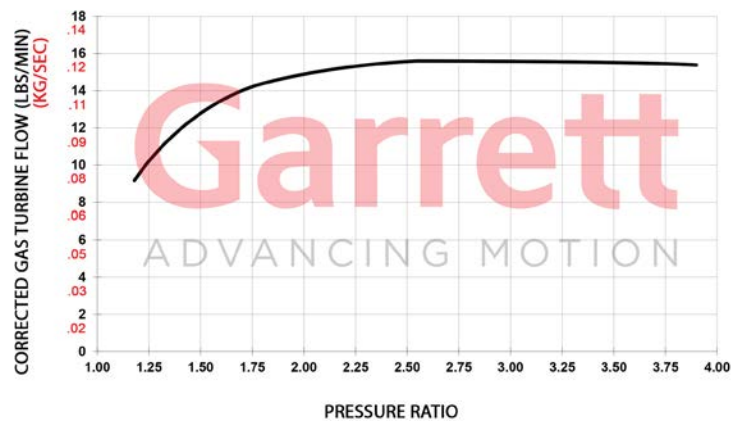

GBC22-350		Compressor			Turbine			
HP: 200-350	Disp: 1.0L-2.5L	Inducer	Exducer	A/R	Inducer	Exducer	Trim	A/R
Turbo PN: 896055-5003S		44mm	56mm	0.59	50mm	46mm	84	0.64

Garrett GBC35-700

Horsepower: 400 - 700
Displacement: 2.0L - 5.0L

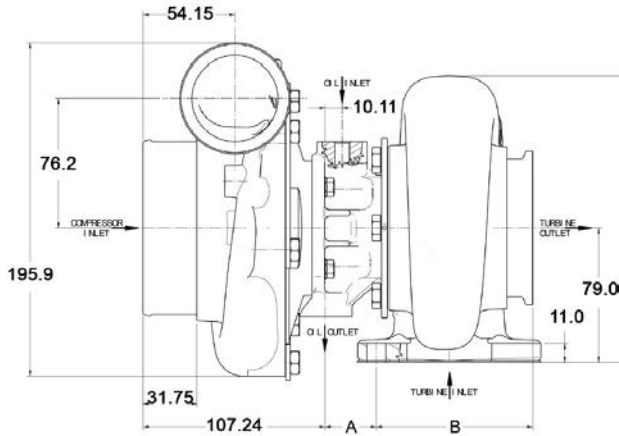

COMPRESSOR MAP

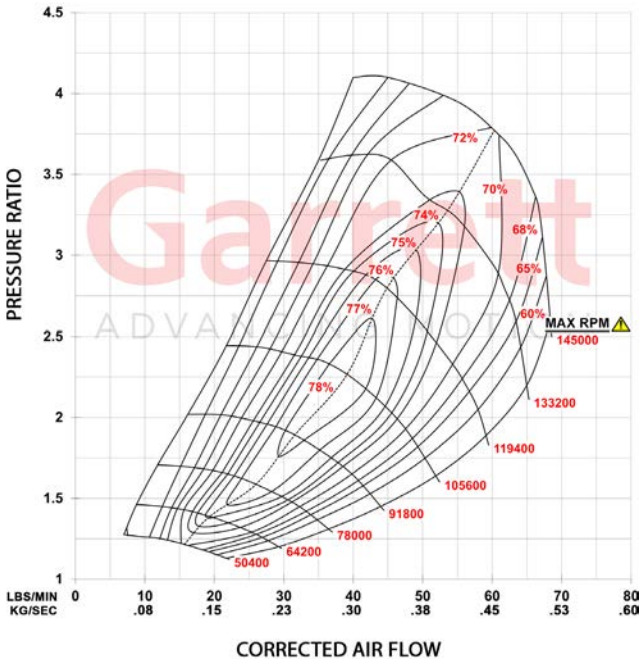

FEATURES:

- ◆ 58MM COMPRESSOR INDUCER | 76MM COMPRESSOR EXDUCER
- ◆ BILLET COMPRESSOR WHEEL WITH EXTENDED TIP DESIGN FOR HIGHER PRESSURE RATIOS
- ◆ JOURNAL BEARING WITH 360-DEGREE THRUST BEARING
- ◆ OUTLINE INTERCHANGEABLE WITH GBC37-900
- ◆ MACHINED BOOST SIGNAL PORT WITH INSTALLED PLUG
- ◆ MODERN TURBINE WHEEL AERODYNAMICS
- ◆ OIL-COOLED CENTER HOUSING

EXHAUST FLOW CHART

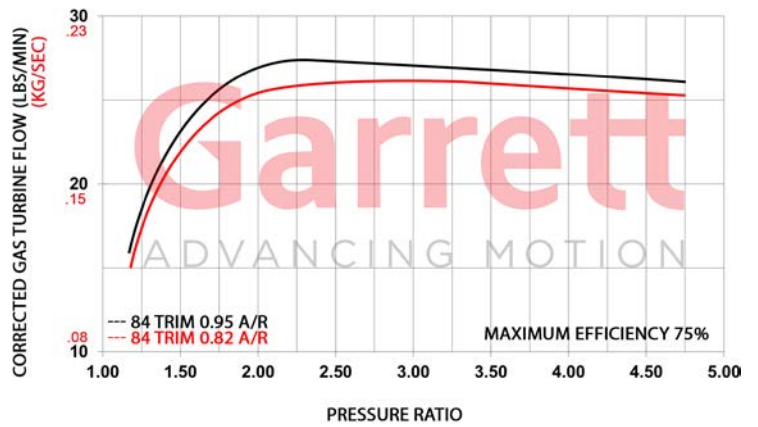

GBC35-700		Compressor				Turbine		
		Inducer	Exducer	Trim	A/R	Inducer	Exducer	Trim
HP: 400-700	Disp: 2.0L-5.0L	58mm	76mm	58	0.72	68mm	62mm	84
Supercore		PN						
		913840-5001S						
Turbine Kits: GBC35		PN		A/R	Inlet	Outlet	Wastegate	Divided
Free Float		740902-0123		0.82	T3	V-Band	External	N
		740902-0124		0.82	T4	V-Band	External	N
		740902-0125		0.95	T4	V-Band	External	Y

Garrett GBC37-900



Horsepower: 450 - 900
Displacement: 2.0L - 5.5L

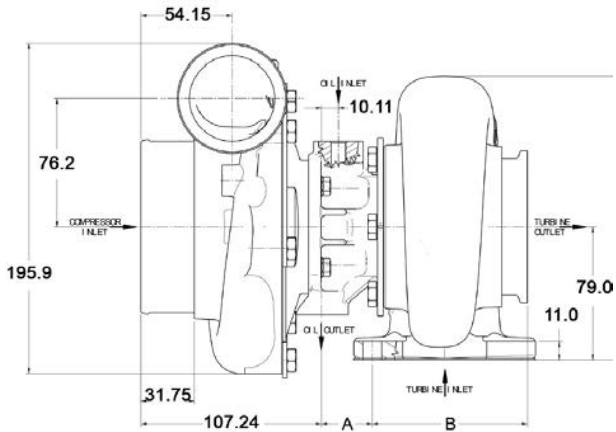

COMPRESSOR MAP

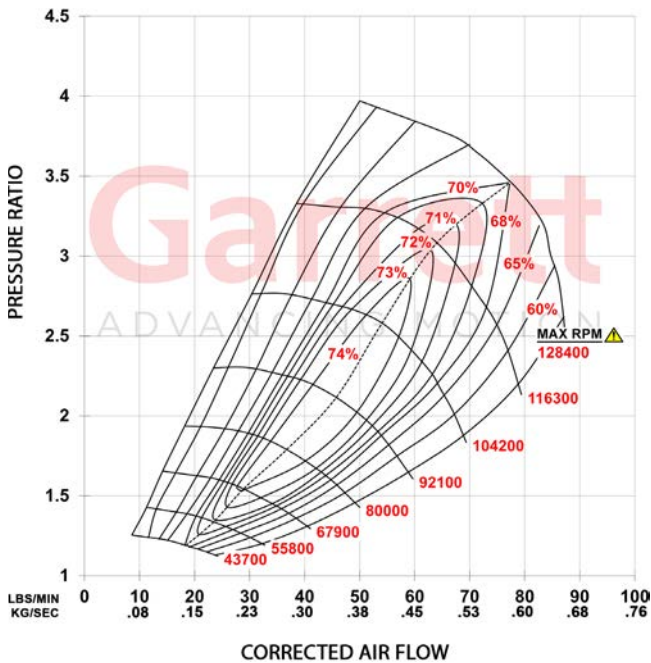

FEATURES:

- ◆ 67MM COMPRESSOR INDUCER | 84MM COMPRESSOR EXDUCER
- ◆ BILLET COMPRESSOR WHEEL WITH EXTENDED TIP DESIGN FOR HIGHER PRESSURE RATIOS
- ◆ JOURNAL BEARING WITH 360-DEGREE THRUST BEARING
- ◆ OUTLINE INTERCHANGEABLE WITH GBC37-900
- ◆ MACHINED BOOST SIGNAL PORT WITH INSTALLED PLUG
- ◆ MODERN TURBINE WHEEL AERODYNAMICS
- ◆ OIL-COOLED CENTER HOUSING

EXHAUST FLOW CHART

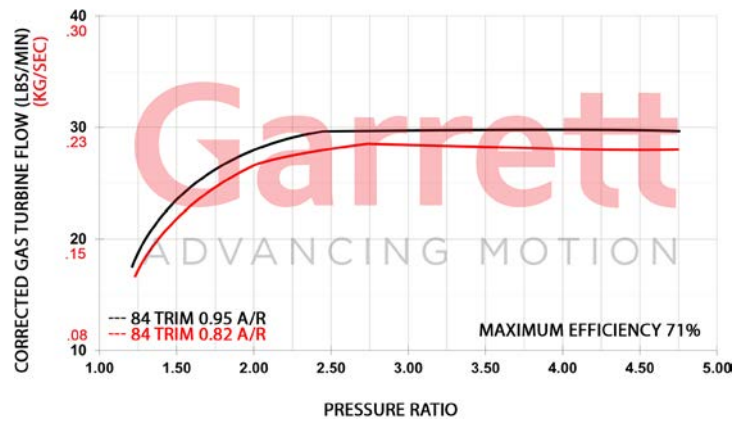

GBC37-900		Compressor				Turbine		
		Inducer	Exducer	Trim	A/R	Inducer	Exducer	Trim
HP: 450-900	Disp: 2.0L-5.5L	67mm	84mm	64	0.72	73mm	65mm	80
Supercore		PN						
		913840-5002S						
Turbine Kits: GBC37		PN	A/R	Inlet	Outlet	Wastegate	Divided	
Free Float		740902-0126	0.82	T3	V-Band	External	N	
		740902-0127	0.82	T4	V-Band	External	N	
		740902-0128	0.95	T4	V-Band	External	Y	

GTW SERIES

GTW Series turbochargers were engineered to provide budget-minded enthusiasts with a high-performing mid frame product that is offered in ball bearing and journal bearing options. GTW combines popular compressor inducer sizes like 58mm | 62mm | 64mm | 67mm with slightly larger (than GTX) turbine wheel sizes.

Fully-machined aluminum compressor wheels with GTX Gen II aero provide optimal horsepower range and boost response for 2.0L - 6.0L engine displacements. A lightweight aluminum backplate comes standard on all GTW turbochargers and reduces overall weight.

The water cooled CHRA keeps housing temperatures to a minimum. The GTW3476 and GTW3884 turbine wheels are constructed from Inconel, a Super Alloy that maintains strength during prolonged exposure to high exhaust gas temperatures. Turbine kits are offered in open volute and twin scroll, and a variety of A/R and flange configurations. The GTW is a cost effective option for enthusiasts looking to turbocharge their vehicles.



Scott Birdsall | Garrett GTW3884R | Pikes Peak International Hill Climb



Garrett GTW3476R

Horsepower: 450 - 700
Displacement: 2.0L - 4.5L

Garrett
ADVANCING MOTION

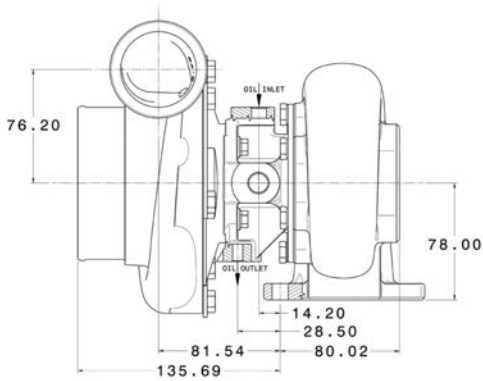

Measurements in MM



COMPRESSOR MAP

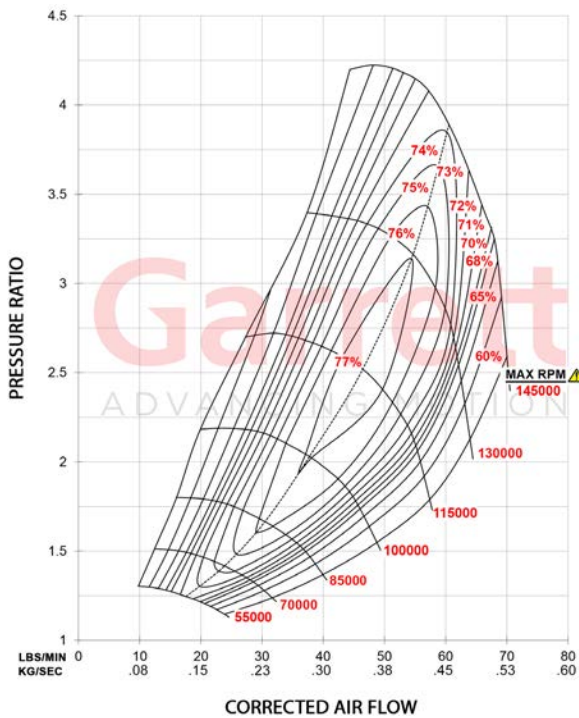

FEATURES:

- ◆ PORTED SHROUD DESIGN FOR SURGE RESISTANCE
- ◆ AVAILABLE IN BOTH JOURNAL BEARING AND BALL BEARING OPTIONS
- ◆ FORGED FULLY-MACHINED BILLET COMPRESSOR WHEEL
- ◆ LIGHTWEIGHT ALUMINUM BACKPLATE
- ◆ INCONEL SUPER-ALLOY TURBINE WHEEL

EXHAUST FLOW CHART

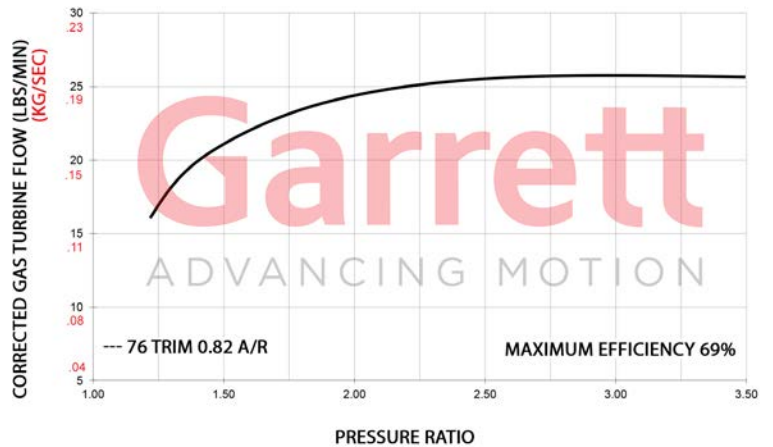

GTW3476R	Compressor				Turbine		
	Inducer	Exducer	Trim	A/R	Inducer	Exducer	Trim
HP: 450-700 Disp: 2.0L-4.5L	58mm	76mm	58	0.70	65mm	57mm	76
Supercore	PN						
Ball Bearing	841691-5001S						
Journal Bearing	841297-5001S						
Turbine Kits: GTW34	PN		A/R	Inlet	Outlet	Wastegate	Divided
Free Float	844669-0002		0.63	T3	4-Bolt	External	N
	844669-0003		0.82	T3	4-Bolt	External	N

Garrett GTW3684R

Horsepower: 425 - 750
 Displacement: 2.0L - 5.3L

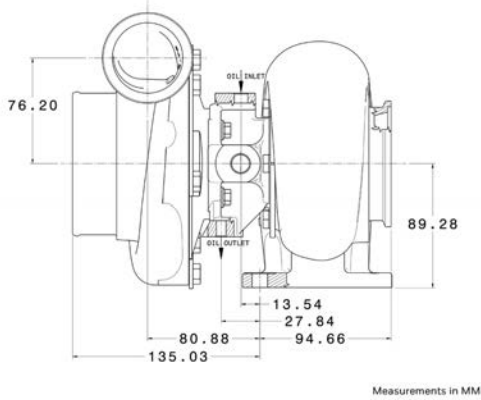

COMPRESSOR MAP

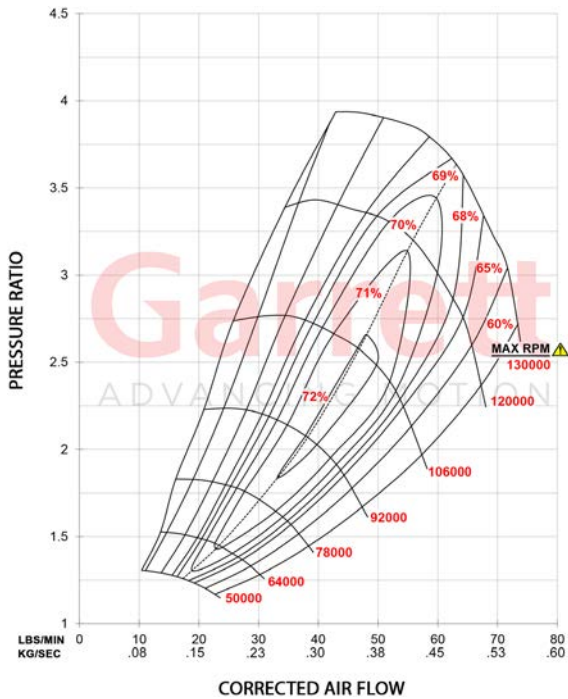

FEATURES:

- ◆ PORTED SHROUD DESIGN FOR SURGE RESISTANCE
- ◆ AVAILABLE IN BOTH JOURNAL BEARING AND BALL BEARING OPTIONS
- ◆ FORGED FULLY-MACHINED BILLET COMPRESSOR WHEEL
- ◆ TURBINE HOUSINGS AVAILABLE IN DIVIDED CONFIGURATION
- ◆ LIGHTWEIGHT ALUMINUM BACKPLATE

EXHAUST FLOW CHART

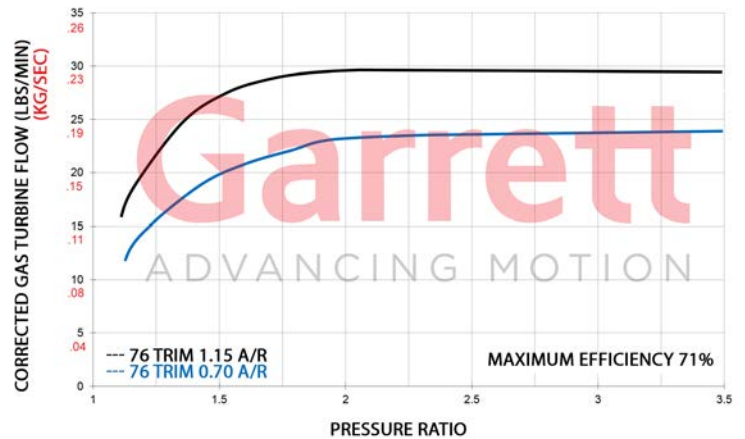

GTW3684R		Compressor				Turbine				
HP: 425-750	Disp: 2.0L-5.3L	Inducer	Exducer	Trim	A/R	Inducer	Exducer	Trim		
Supercore		PN								
Ball Bearing		841691-5002S								
Journal Bearing		841297-5002S								
Turbine Kits: GTW36		PN				A/R	Inlet	Outlet	Wastegate	Divided
Free Float		844669-0005		0.70		T4	V-Band	External	Y	
		844669-0007		1.15		T4	V-Band	External	Y	

Garrett GTW3884R

Horsepower: 450 - 950
Displacement: 2.0L - 6.0L

Garrett
ADVANCING MOTION

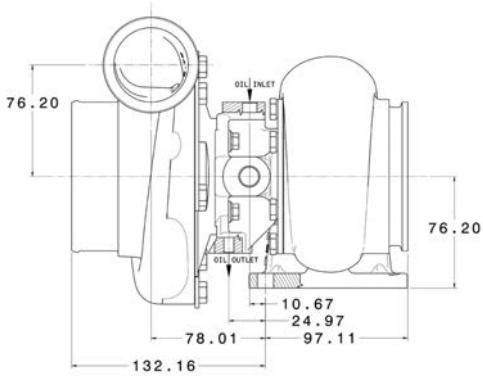

Measurements in MM



COMPRESSOR MAP

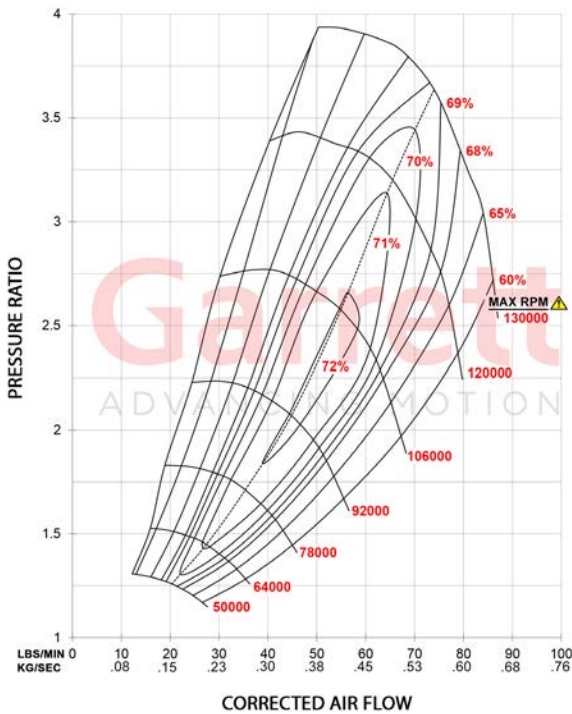

FEATURES:

- ◆ PORTED SHROUD DESIGN FOR SURGE RESISTANCE
- ◆ AVAILABLE IN JOURNAL BEARING OR BALL BEARING OPTIONS
- ◆ FORGED FULLY-MACHINED BILLET COMPRESSOR WHEEL
- ◆ INCONEL SUPER-ALLOY TURBINE WHEEL
- ◆ LIGHTWEIGHT ALUMINUM BACKPLATE

EXHAUST FLOW CHART

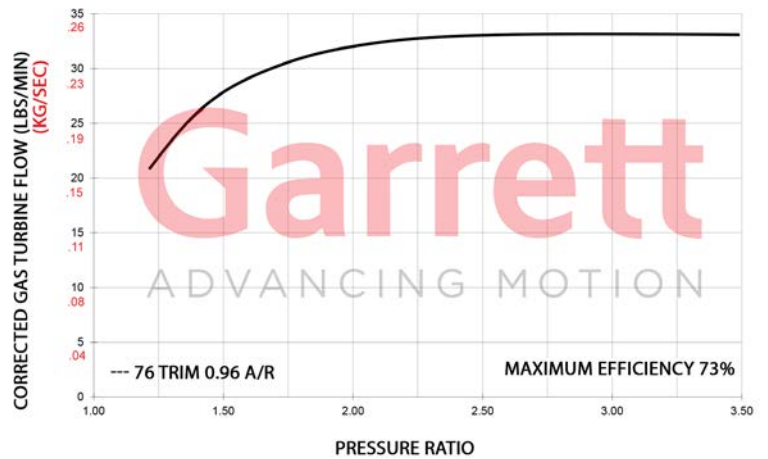

GTW3884R		Compressor				Turbine		
HP: 450-950	Disp: 2.0L-6.0L	Inducer	Exducer	Trim	A/R	Inducer	Exducer	Trim
Supercore	PN							
Ball Bearing	841691-5003S	62mm	84mm	54	0.70	74mm	65mm	76
Ball Bearing	841691-5004S	64mm	84mm	58	0.70	74mm	65mm	76
Ball Bearing	841691-5005S	67mm	84mm	64	0.70	74mm	65mm	76
Journal Bearing	841297-5003S	62mm	84mm	54	0.70	74mm	65mm	76
Journal Bearing	841297-5004S	64mm	84mm	58	0.70	74mm	65mm	76
Journal Bearing	841297-5005S	67mm	84mm	64	0.70	74mm	65mm	76
Turbine Kits: GTW38		PN		A/R	Inlet	Outlet	Wastegate	Divided
Free Float		844669-0009		0.96	T4	V-Band	External	N



GARRETT GEAR

BOOST APPAREL & CULTURE

GARRETTGEAR.COM

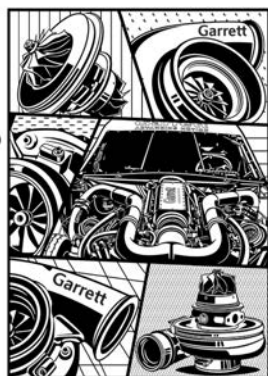

GT SERIES

Garrett GT Series is the name that pioneered turbo technology and boosted drag racing and road racing teams to break hundreds of world records. The GT Series lineup is offered in both journal and ball bearing options, with sizes ranging from GT2052 to GT3582.

The cast compressor wheels feature original GT Series aerodynamics and provide maximum durability and longevity. Internally wastegated turbine housing options are available in all GT Series sizes.

Turbine kits are offered in open volute and twin scroll, and a variety of A/R and flange configurations. For any performance need, GT Series turbochargers have you covered.





Garrett GT2052

Horsepower: 140 - 230
 Displacement: 1.4L - 2.0L

Garrett
 ADVANCING MOTION

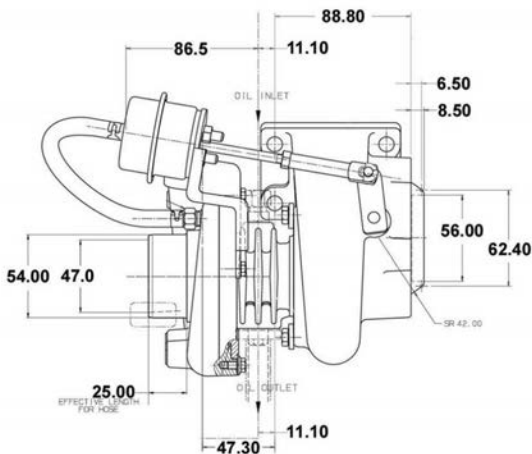

Measurements in MM

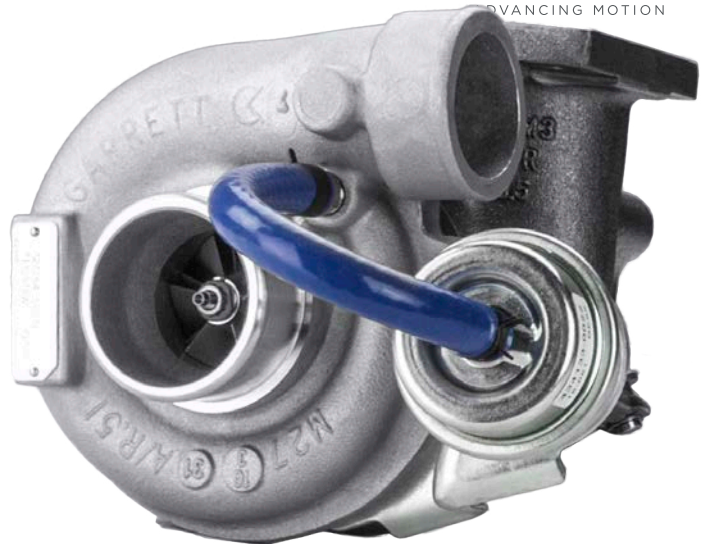

COMPRESSOR MAP

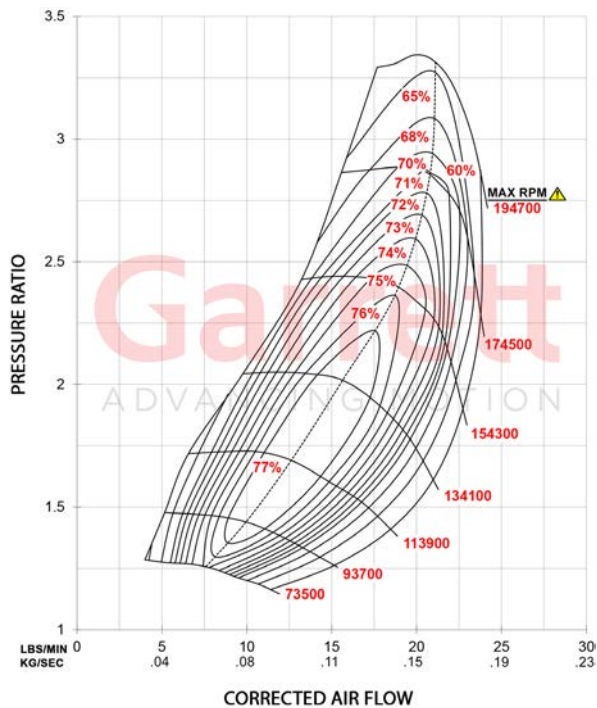

FEATURES:

- ◆ ORIGINAL GT SERIES AERODYNAMICS
- ◆ INTERNALLY WASTEGATED TURBINE HOUSING
- ◆ SOLD AS A COMPLETE TURBO (INCLUDES TURBINE KIT)
- ◆ JOURNAL BEARING CONFIGURATION
- ◆ OIL COOLED CHRA

EXHAUST FLOW CHART

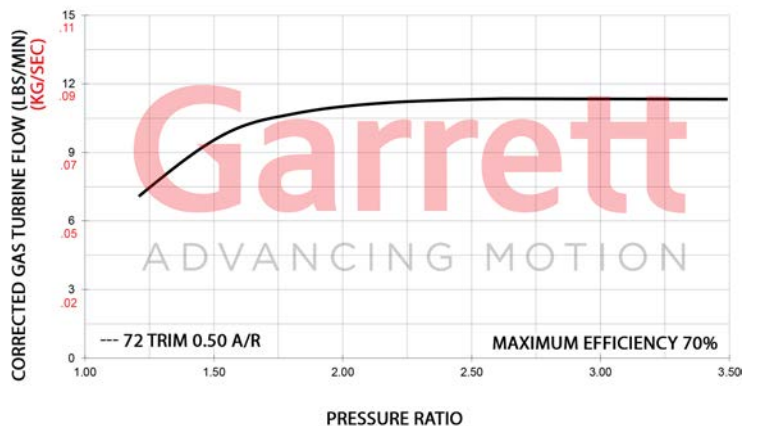

GT2052		Compressor			Turbine			
HP: 140-230	Disp: 1.4L-2.0L	Inducer	Exducer	A/R	Inducer	Exducer	Trim	A/R
Turbo PN: 727264-5001W		38mm	52mm	0.51	47mm	40mm	72	0.50

Garrett GT2252

Horsepower: 150 - 260
Displacement: 1.7L - 2.5L

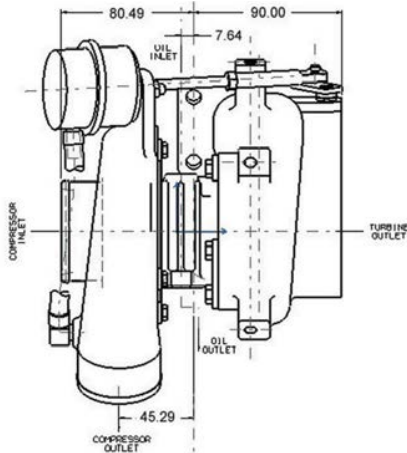

Measurements in MM



COMPRESSOR MAP

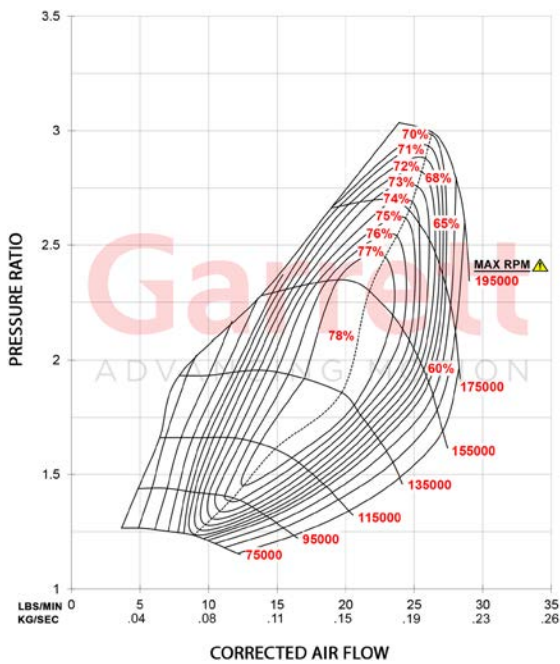

FEATURES:

- ◆ ORIGINAL GT SERIES AERODYNAMICS
- ◆ INTERNALLY WASTEGATED TURBINE HOUSING
- ◆ SOLD AS A COMPLETE TURBO (INCLUDES TURBINE KIT & ACTUATOR)
- ◆ JOURNAL BEARING CONFIGURATION
- ◆ OIL COOLED CHRA

EXHAUST FLOW CHART

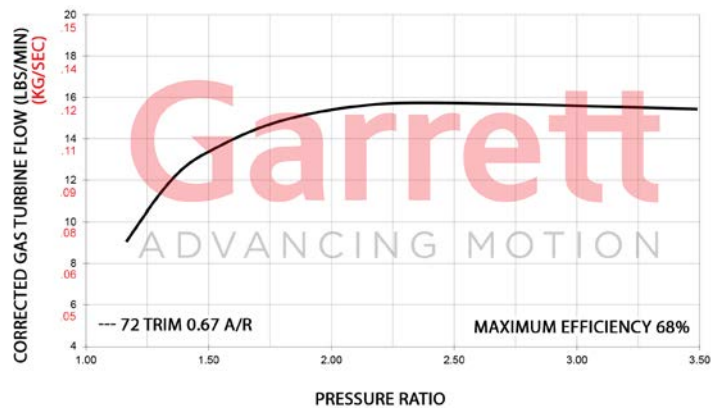

GT2252		Compressor			Turbine			
HP: 150-260	Disp: 1.7L-2.5L	Inducer	Exducer	A/R	Inducer	Exducer	Trim	A/R
Turbo PN: 452187-5006S		40mm	52mm	0.51	50mm	43mm	72	0.67

Garrett GT2554R

Horsepower: 170 - 270
 Displacement: 1.4L - 2.2L

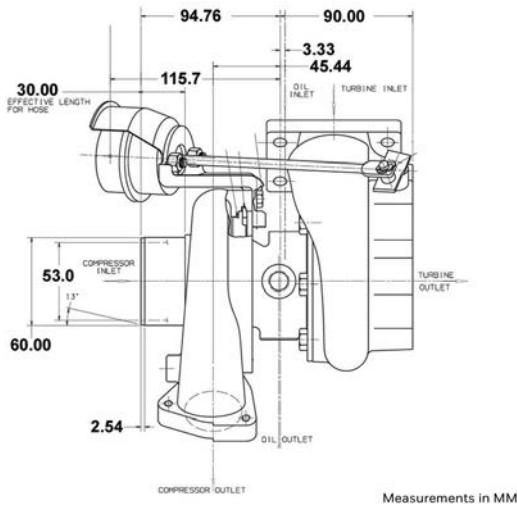

COMPRESSOR MAP



FEATURES:

- ◆ ORIGINAL GT SERIES AERODYNAMICS
- ◆ INTERNALLY WASTEGATED TURBINE HOUSING
- ◆ SOLD AS A COMPLETE TURBO (INCLUDES TURBINE KIT & ACTUATOR)
- ◆ SMALLEST BALL BEARING CONFIGURATION AVAILABLE
- ◆ WATER COOLED CHRA

EXHAUST FLOW CHART

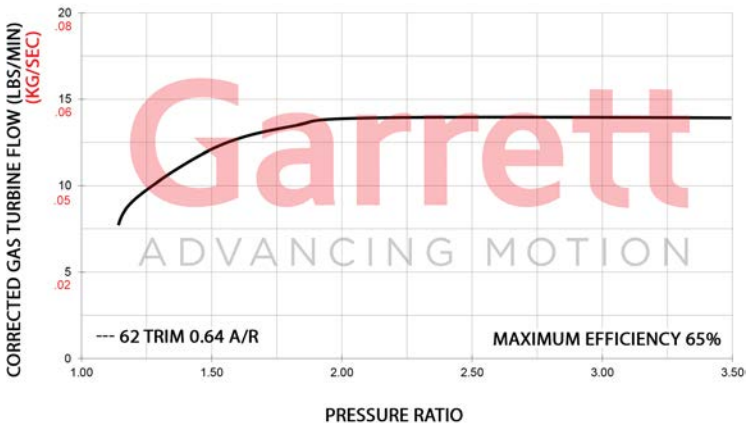

GT2554R		Compressor			Turbine			
HP: 170-270	Disp: 1.4L-2.2L	Inducer	Exducer	A/R	Inducer	Exducer	Trim	A/R
Turbo PN: 836023-5001S		42mm	54mm	0.80	53mm	42mm	62	0.64

Garrett GT2560R

Horsepower: 200 - 330
 Displacement: 1.6L - 2.5L

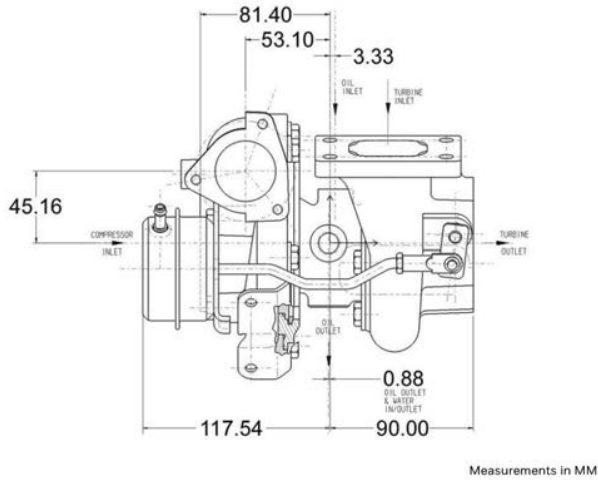

COMPRESSOR MAP

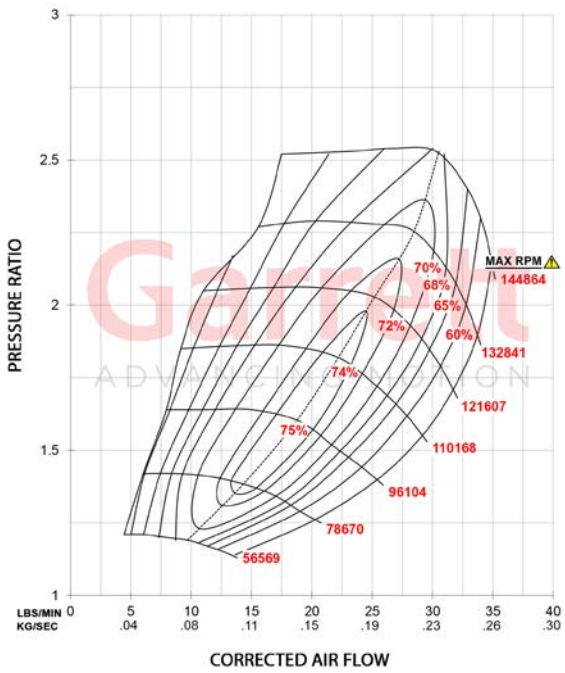

FEATURES:

- ◆ ORIGINAL GT SERIES AERODYNAMICS
- ◆ INTERNALLY WASTEGATED TURBINE HOUSING
- ◆ SOLD AS A COMPLETE TURBO (INCLUDES TURBINE KIT & ACTUATOR)
- ◆ BALL BEARING CONFIGURATION WITH WATER COOLED CHRA

EXHAUST FLOW CHART

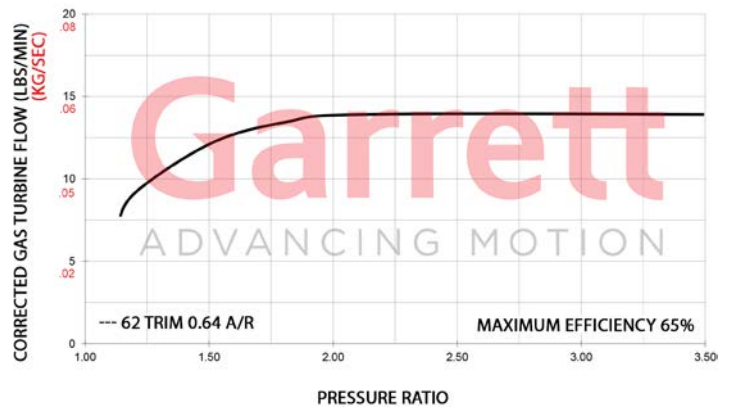

GT2560R		Compressor			Turbine			
HP: 200-330	Disp: 1.6L-2.5L	Inducer	Exducer	A/R	Inducer	Exducer	Trim	A/R
Turbo PN: 836023-5004S		46mm	60mm	0.80	53mm	42mm	62	0.64

Garrett GT2860R

Horsepower: 250 - 360
Displacement: 1.8L - 3.0L

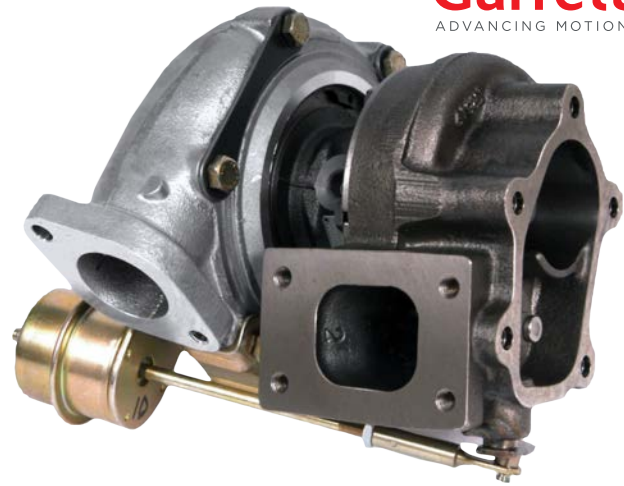
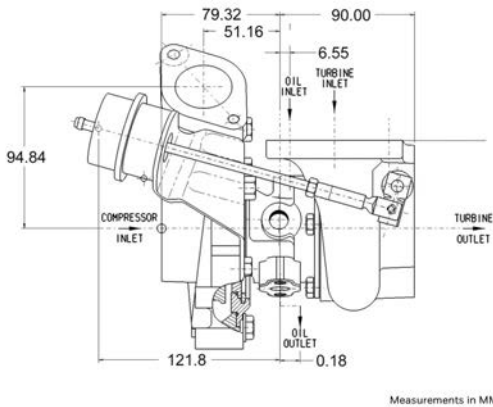

COMPRESSOR MAP

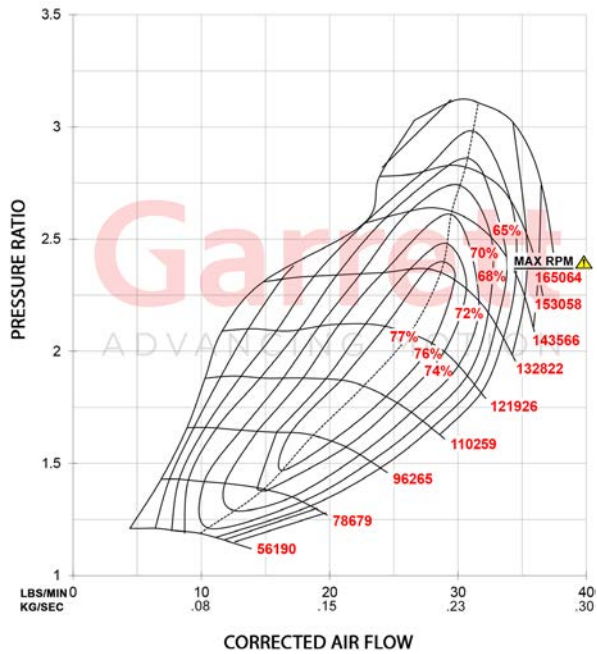

FEATURES:

- ◆ ORIGINAL GT SERIES AERODYNAMICS
- ◆ INTERNALLY WASTEGATED TURBINE HOUSING
- ◆ SOLD AS A COMPLETE TURBO (INCLUDES TURBINE KIT & ACTUATOR)
- ◆ BALL BEARING CONFIGURATION WITH WATER COOLED CHRA
- ◆ V-BAND TURBINE HOUSING OPTIONS
- ◆ BOLT-ON UPGRADE FOR NISSAN RB26DETT

EXHAUST FLOW CHART

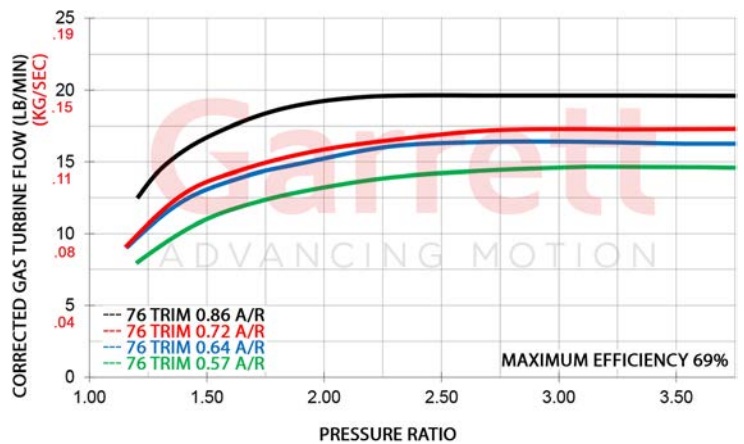

GT2860R HP: 250-360 Disp: 1.8L-3.0L Turbo PN: 836026-5005S	Compressor			Turbine			
	Inducer	Exducer	A/R	Inducer	Exducer	Trim	A/R
	47mm	60mm	0.60	54mm	47mm	76	0.64
Turbine Kits: GT28		PN	A/R	Inlet	Outlet	Wastegate	Divided
Kits not directly interchangeable.	827690-0005		0.64	T25	5-Bolt	Internal	N
Modifications required to the	827690-0004		0.86	T25	5-Bolt	Internal	N
exhaust system to fit.	827690-0001		0.57	V-Band	V-Band	External	N
	827690-0002		0.72	V-Band	V-Band	External	N

Garrett GT2860RS

Horsepower: 250 - 360

Displacement: 1.8L - 3.0L

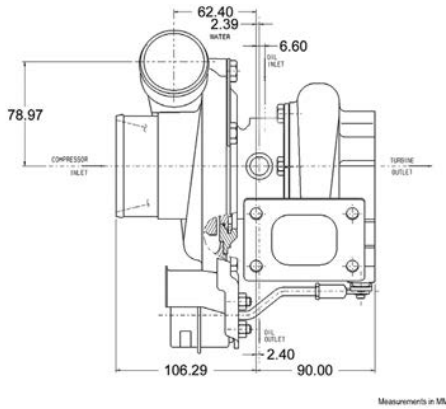

Measurements in MM



COMPRESSOR MAP

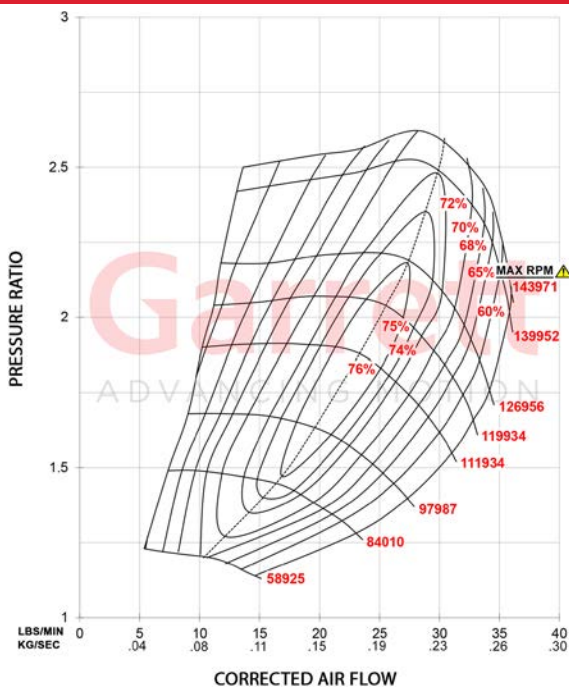

FEATURES:

- ◆ ORIGINAL GT SERIES AERODYNAMICS
- ◆ INTERNALLY WASTEGATED TURBINE HOUSING
- ◆ SOLD AS A COMPLETE TURBO (INCLUDES TURBINE KIT & ACTUATOR)
- ◆ BALL BEARING CONFIGURATION WITH WATER COOLED CHRA
- ◆ V-BAND TURBINE HOUSING OPTIONS

EXHAUST FLOW CHART

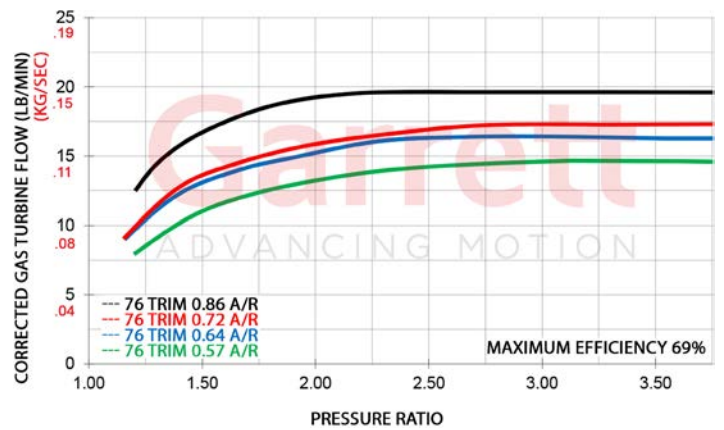

GT2860RS HP: 250-360 Disp: 1.8L-3.0L	Compressor			Turbine			
	Inducer	Exducer	A/R	Inducer	Exducer	Trim	A/R
Turbo PN: 836026-5013S	47mm	60mm	0.60	54mm	47mm	76	0.86
Turbo PN: 836026-5014S	47mm	60mm	0.60	54mm	47mm	76	0.64
Turbine Kits: GT28	PN	A/R	Inlet	Outlet	Wastegate	Divided	
Kits not directly interchangeable.	827690-0005	0.64	T25	5-Bolt	Internal	N	
Modifications required to the	827690-0004	0.86	T25	5-Bolt	Internal	N	
exhaust system to fit.	827690-0001	0.57	V-Band	V-Band	External	N	
	827690-0002	0.72	V-Band	V-Band	External	N	

Garrett GT2871R

Horsepower: 280 - 475
Displacement: 1.8L - 3.0L

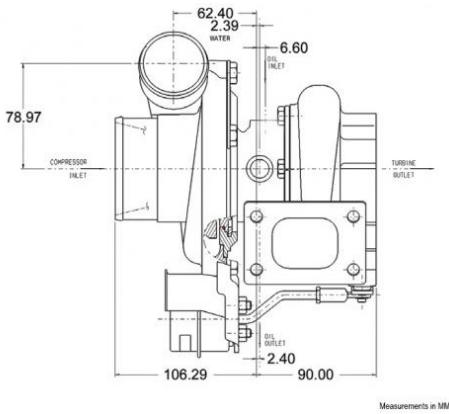

COMPRESSOR MAP

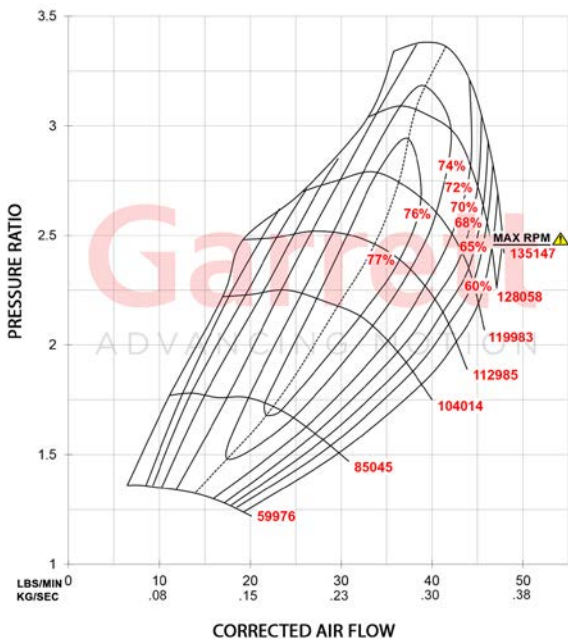

FEATURES:

- ◆ ORIGINAL GT SERIES AERODYNAMICS
- ◆ INTERNALLY WASTEGATED TURBINE HOUSING OPTIONS
- ◆ NON WASTEGATED TURBINE HOUSINGS AVAILABLE
- ◆ SOLD AS A COMPLETE TURBO (INCLUDES TURBINE KIT & ACTUATOR)
- ◆ BALL BEARING CONFIGURATION WITH WATER COOLED CHRA
- ◆ V-BAND TURBINE HOUSING OPTIONS

EXHAUST FLOW CHART

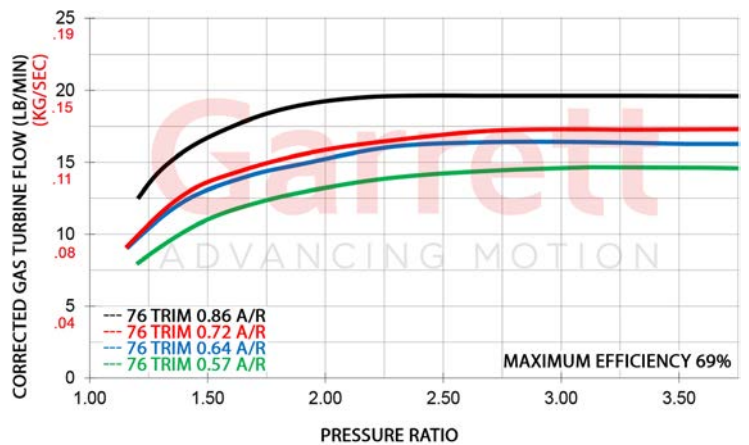

GT2871R HP: 280-475 Disp: 1.8L-3.0L	Compressor			Turbine			
	Inducer	Exducer	A/R	Inducer	Exducer	Trim	A/R
Turbo PN: 836026-5020S	53mm	71mm	0.60	54mm	47mm	76	0.86
Turbo PN: 836026-5021S	53mm	71mm	0.60	54mm	47mm	76	0.64
Turbine Kits: GT28	PN		A/R	Inlet	Outlet	Wastegate	Divided
Kits not directly interchangeable.	827690-0005		0.64	T25	5-Bolt	Internal	N
Modifications required to the exhaust system to fit.	827690-0004		0.86	T25	5-Bolt	Internal	N
	827690-0001		0.57	V-Band	V-Band	External	N
	827690-0002		0.72	V-Band	V-Band	External	N

Garrett GT3071R

Horsepower: 280 - 480
Displacement: 2.5L - 3.5L

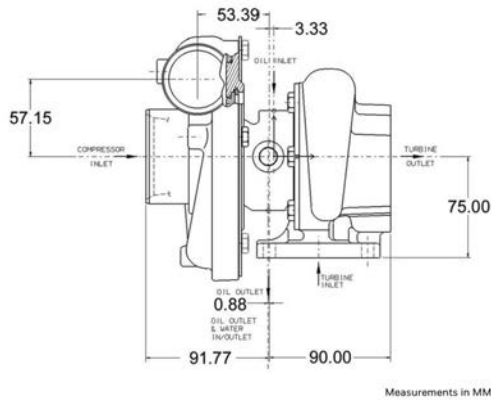

COMPRESSOR MAP



FEATURES:

- ◆ ORIGINAL GT SERIES AERODYNAMICS
- ◆ NON WASTEGATED TURBINE HOUSINGS AVAILABLE
- ◆ BALL BEARING CONFIGURATION WITH WATER COOLED CHRA
- ◆ V-BAND AND T3 TURBINE HOUSING INLET OPTIONS

EXHAUST FLOW CHART

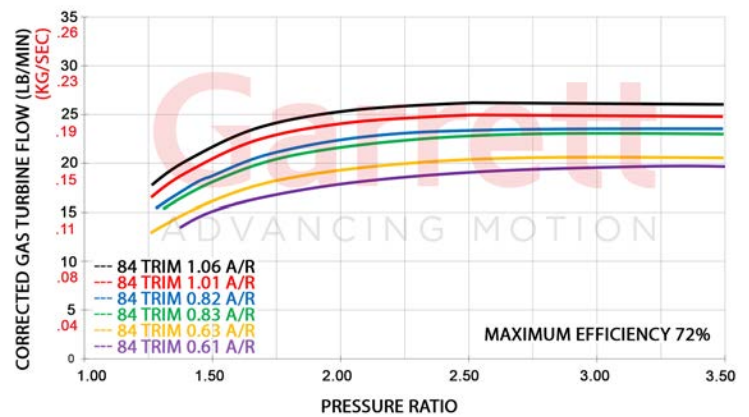

GT3071R		Compressor			Turbine		
HP: 280-480	Disp: 2.5L-3.5L	Inducer	Exducer	A/R	Inducer	Exducer	Trim
Supercore PN							
836028-5001S	69.85mm hose / square heat shroud	53mm	71mm	0.50	60mm	55mm	84
836028-5002S	102.00mm hose / square heat shroud	53mm	71mm	0.50	60mm	55mm	84
836028-5005S	102.00mm hose / stepped heat shroud	53mm	71mm	0.50	60mm	55mm	84
Turbine Kits: GT30		PN	A/R	Inlet	Outlet	Wastegate	Divided
Free Float		740902-0009	0.63	T3	V-Band	External	N
		740902-0008	0.82	T3	V-Band	External	N
		740902-0007	1.06	T3	V-Band	External	N
		740902-0036	0.61	V-Band	V-Band	External	N
		740902-0035	0.83	V-Band	V-Band	External	N
		740902-0034	1.01	V-Band	V-Band	External	N
		PN	A/R	Inlet	Outlet	Wastegate	Divided
771300 turbine assembly does not include bolts, clamps, or actuator		771300-0006	0.63	T3	5 bolt	Internal	N
		771300-0005	0.82	T3	5 bolt	Internal	N
		771300-0004	1.06	T3	5 bolt	Internal	N

Garrett GT3076R

Horsepower: 310 - 525

Displacement: 2.0L - 3.5L

Garrett
ADVANCING MOTION

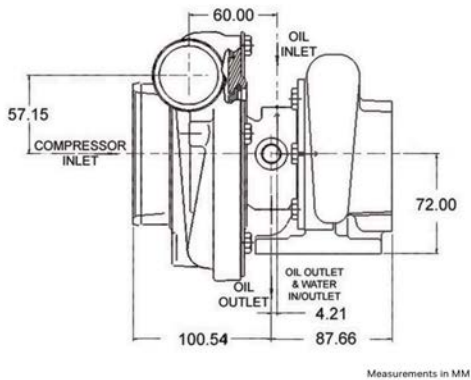

COMPRESSOR MAP

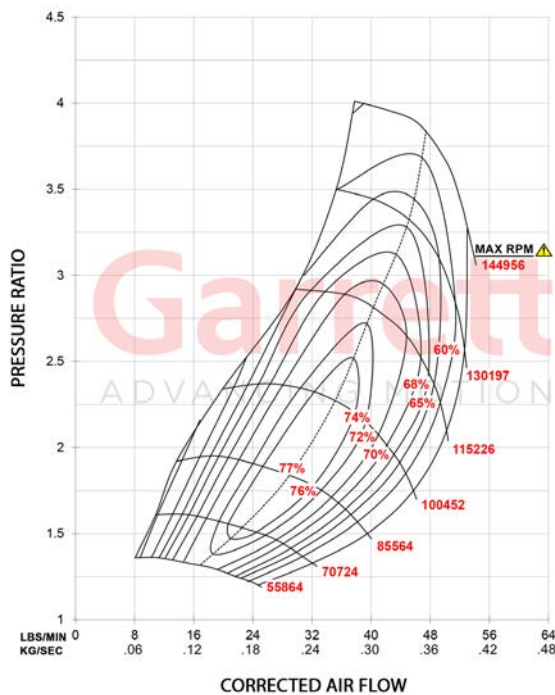

FEATURES:

- ◆ ORIGINAL GT SERIES AERODYNAMICS
- ◆ INTERNALLY WASTEGATED TURBINE HOUSING
- ◆ NON WASTEGATED TURBINE HOUSINGS AVAILABLE
- ◆ BALL BEARING CONFIGURATION WITH WATER COOLED CHRA
- ◆ V-BAND TURBINE HOUSING OPTIONS

EXHAUST FLOW CHART

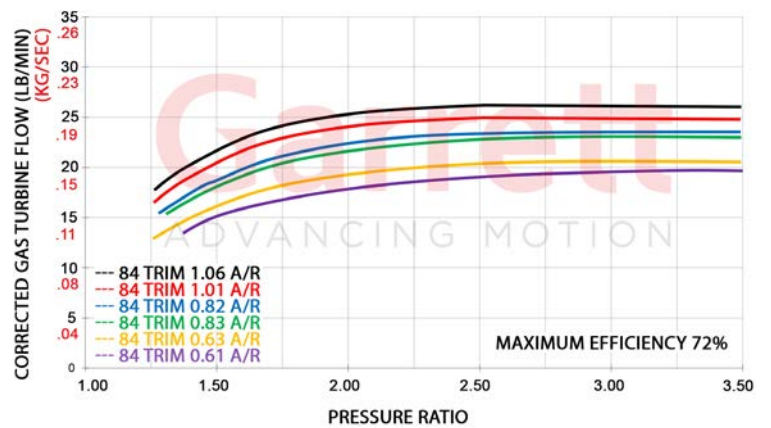

GT3076R	Compressor				Turbine		
	Inducer	Exducer	Trim	A/R	Inducer	Exducer	Trim
HP: 310-525 Disp: 2.0L-3.5L	57mm	76mm	56	0.60	60mm	55mm	84
Supercore	PN						
	836028-5003S						
Turbine Kits: GT30	PN		A/R	Inlet	Outlet	Wastegate	Divided
Free Float	740902-0009		0.63	T3	V-Band	External	N
	740902-0008		0.82	T3	V-Band	External	N
	740902-0007		1.06	T3	V-Band	External	N
	740902-0036		0.61	V-Band	V-Band	External	N
	740902-0035		0.83	V-Band	V-Band	External	N
	740902-0034		1.01	V-Band	V-Band	External	N
	PN		A/R	Inlet	Outlet	Wastegate	Divided
771300 turbine assembly does not include bolts, clamps, or actuator	771300-0006		0.63	T3	5 bolt	Internal	N
	771300-0005		0.82	T3	5 bolt	Internal	N
	771300-0004		1.06	T3	5 bolt	Internal	N

Garrett GT3582R

Horsepower: 400 - 675
Displacement: 2.0L - 4.5L

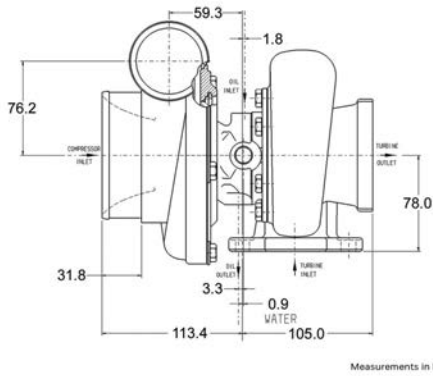

COMPRESSOR MAP

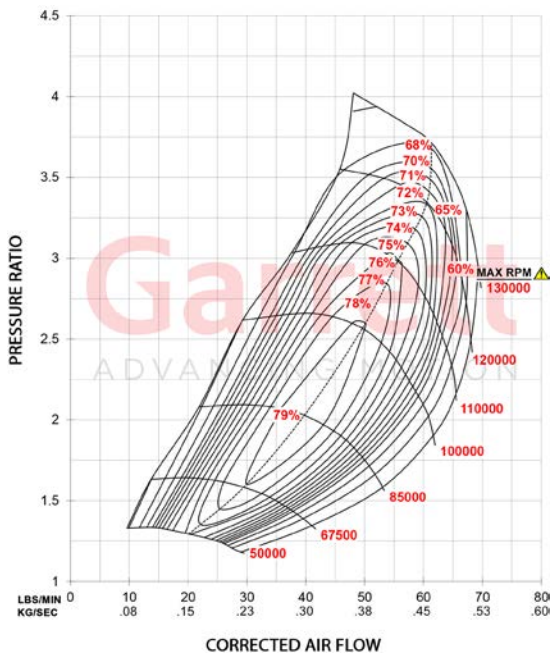

FEATURES:

- ◆ ORIGINAL GT SERIES AERODYNAMICS
- ◆ INTERNALLY WASTEGATED TURBINE HOUSING
- ◆ NON WASTEGATED TURBINE HOUSINGS AVAILABLE
- ◆ BALL BEARING CONFIGURATION WITH WATER COOLED CHRA
- ◆ V-BAND TURBINE HOUSING OPTIONS

EXHAUST FLOW CHART

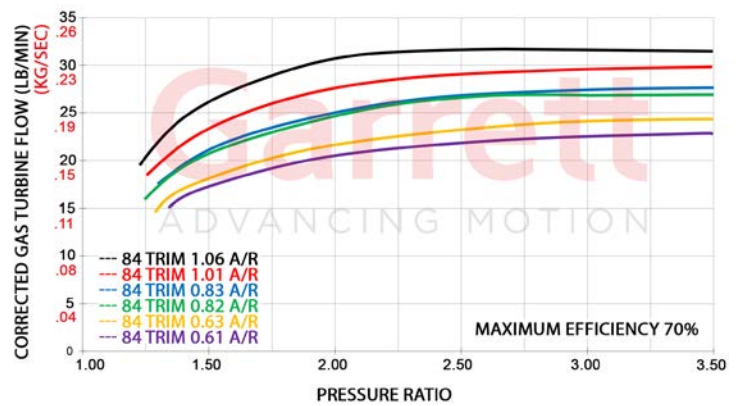

GT3582R		Compressor				Turbine		
		Inducer	Exducer	Trim	A/R	Inducer	Exducer	Trim
HP: 400-675	Disp: 2.0L-4.5L	61mm	82mm	56	0.70	68mm	62mm	84
Supercore		PN						
		836033-5002S						
Turbine Kits: GT35		PN	A/R	Inlet	Outlet	Wastegate	Divided	
Free Float		740902-0012	0.63	T3	V-Band	External	N	
		740902-0011	0.82	T3	V-Band	External	N	
		740902-0010	1.06	T3	V-Band	External	N	
		740902-0018	0.63	T4	V-Band	External	N	
		740902-0017	0.82	T4	V-Band	External	N	
		740902-0016	1.06	T4	V-Band	External	N	
		740902-0033	0.61	V-Band	V-Band	External	N	
		740902-0032	0.83	V-Band	V-Band	External	N	
		740902-0031	1.01	V-Band	V-Band	External	N	
		PN	A/R	Inlet	Outlet	Wastegate	Divided	
771300 turbine assembly does not include bolts, clamps, or actuator		771300-0003	0.63	T3	5 Bolt	Internal	N	
		771300-0002	0.82	T3	5 Bolt	Internal	N	

GARRETT CLASSIC

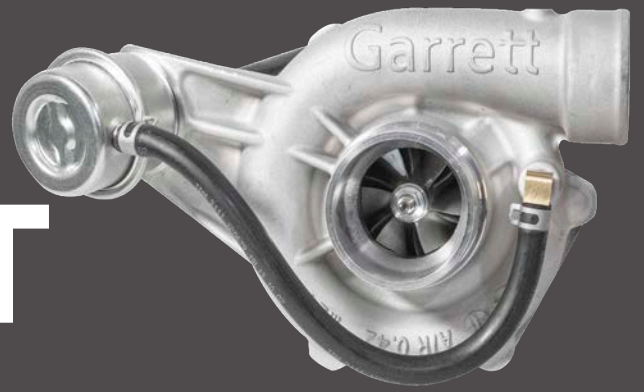

Garrett Classic Turbochargers seamlessly blend modern engineering with direct-fit installation, designed specifically for iconic European cars that ignited the auto industry's turbo revolution. Experience unparalleled performance and reliability, ensuring your vehicle maintains its legendary status while embracing cutting-edge technology.



Garrett Classic Turbo

Lancia Delta HF Integrale

Part Number: 917375-5004W



Garrett | Classic Turbo incorporates modern engineering with direct-fit installation for the iconic Lancia Delta HF Integrale 8V, 16V | Lancia Dedra | Alfa 155 2.0 Q4 | Fiat Coupe 16V. The modern journal bearing rotating group utilizes a 360-degree thrust bearing for improved reliability. Garrett integrated the actuator bracket into the compressor housing to strengthen the turbocharger. This turbocharger includes a gasket kit for a direct-fit installation.

FEATURES

- 360-degree thrust bearing to improve reliability and durability of the rotor system during extreme operating conditions
- Wastegate actuator bracket is cast into the compressor housing to improve stiffness against engine vibration
- Robust turbine housing, engineered using of thermal simulation to avoid cracks and other failures
- Includes gasket kit 917890-0001 (Turbine inlet, oil inlet, oil outlet)
- Direct-fit installation



Application List

Model	Year	Garrett DSR PN	Garrett PN	OE PN
Lancia Delta HF Integrale (8V, catalytic converter) Lancia Delta HF Integrale 16V	1989-1991	917375-5004W	465103-5002S	76317230
			465103-5004S	77202760
465103-5006S	76863370			
465103-5009S	77294710			
Lancia Dedra 2.0 Turbo Integrale	1991-1994		465103-5009S	77294710
Alfa 155 2.0 Q4 16V Turbo	1992-1994		465103-5004S	77202760
Fiat Coupé 2.0 16V Turbo	1993-1996		465103-5004S	77202760

Garrett Classic Turbo

Renault 5 Turbo 1 & 2

Part Number: 920072-5001W



Introducing the Garrett Classic Turbo - the perfect blend of modern engineering and iconic design for your Renault 5 Turbo. Our state-of-the-art engineering technology ensures the ultimate driving experience by combining performance and reliability with direct-fit installation. It's journal bearing rotating group incorporates a 360-degree thrust bearing for enhanced reliability. We've integrated the actuator bracket into the compressor housing to ensure a stronger, more durable turbocharger that will keep your Renault 5 Turbo running smoothly for years to come.

Don't settle for anything less than world-class engineering and reliability for your automotive investment. By choosing Garrett Classic, the only original turbo, for the ultimate upgrade on your Renault 5 Turbo, you will increase the value of your car and you elevate your driving experience.

Model	Year	Garrett DSR PN	Garrett PN
Renault 5 Turbo 1	1980-1982	920072-5001W	465646-5003S
Renault 5 Turbo 2	1983-1985		465646-5004S



FEATURES

- 360-degree thrust bearing to improve reliability and durability of the rotor system during extreme operating conditions
- Wastegate actuator bracket is cast into the compressor housing to improve stiffness against engine vibration
- Robust turbine housing, engineered using of thermal simulation to avoid cracks and other failures
- Includes gasket kit 917890-0002 (oil inlet, oil outlet)
- Direct-fit installation

Garrett Classic Turbo

Lancia Delta HF Integrale 16V and 16V Evo1

Part Number: 917375-5005W



Garrett | Classic Turbo incorporates modern engineering with direct-fit installation for the iconic Lancia Delta 2.0 16V HF Integrale and EVO 1. The modern journal bearing rotating group utilizes a 360-degree thrust bearing for improved reliability. This turbocharger includes a gasket kit for a direct-fit installation.



FEATURES

- 360-degree thrust bearing to improve reliability and durability of the rotor system during extreme operating conditions
- Separate Wastegate actuator bracket mounted to the compressor housing
- Robust turbine housing, engineered using of thermal simulation to avoid cracks and other failures
- Includes gasket kit 917890-0001 (Turbine inlet, oil inlet, oil outlet)
- Direct-fit installation

Application List

Model	Year	Garrett DSR PN	Garrett PN	OE PN
Lancia Delta HF Integrale 16V Evo 1	1991-1992	917375-5005W	465553-5001S	7662974
				46234219
Lancia Delta HF Integrale 16V	1989-1991			7662974

GARRETT VENT | WASTEGATES



Garrett Vent | External Wastegates regulate turbocharger shaft speed by venting exhaust gas around the turbine stage of the turbocharger. CFD optimized design maximizes flow and delivers optimum boost control. Advanced thermal optimization increases durability of the diaphragm. The cap design makes spring changes and serviceability of the entire GVW lineup easier and more reliable to perform.



Garrett Vent | External wastegates are created by the engineers that designed G-Series and GTX Gen II turbochargers. Available in three sizes: 40mm | 45mm | 50mm and four color combinations: Red | Blue | Black | Silver. The valve housing is cast from high temp stainless steel and rated for exhaust temperatures up to 1050° C. CFD optimized for maximum flow and thermal efficiency. Our Nomex reinforced elastomer diaphragm provides exceptional durability and fatigue resistance.

GVW wastegates are set to 1 Bar | 14.5 PSI of base pressure and can be configured from 0.2 Bar | 2.9 PSI - 1.7 Bar | 24.7 PSI (considering 1:1 back pressure). The actuator design allows for multiple air/liquid fitting orientations. All fasteners, springs, fittings, V-bands, clamps, and flanges included. For pricing and availability please contact an authorized distributor.

Model	Base Pressure	Red	Blue	Black	Silver
GVW-40	1 Bar 14.5 PSI	908827-0001	908827-0002	908827-0003	908827-0004
GVW-45	1 Bar 14.5 PSI	908828-0001	908828-0002	908828-0003	908828-0004
GVW-50	1 Bar 14.5 PSI	908829-0001	908829-0002	908829-0003	908829-0004
GVW-60	1 Bar 14.5 PSI	908830-0001	908830-0002	908830-0003	908830-0004

Features:

- CFD tested for maximum flow and thermal efficiency
- Optimized actuation stability and temperature resistance for superior durability
- Replaceable valve and bushing components to increase service life
- Robust design for easy diaphragm replacement
- Liquid-cooled actuator ports for use on severe applications (up to 52% reduction in body temp)
- Anodized aluminum actuator cover



Mechanical Data	GVW-40	GVW-45	GVW-50	GVW-60
Valve Diameter	40mm	45mm	50mm	60mm
Valve Mass	1.27kg 45oz	1.47kg 52oz	1.56kg 55oz	1.74kg 61oz
Max Spring Base Pressure	1.7 bar 25 psi (1:1 backpressure ratio)			
Minimum Spring Base Pressure	0.2 bar 3 psi (1:1 backpressure ratio)			
Port Fitting: Air	M10x1.0 to hose barb (Hose ID 6mm .25in)			
Port Fitting: Liquid	M8x1.0 to AN-3			

Material Data	GVW-40 GVW-45 GVW-50 GVW-60
Valve Housing	High temp stainless steel rated up to 1050°C
Diaphragm	High temp Nomex reinforced elastomer
Actuator Cover	Fully-machined anodized 6061 aluminum
Valve Guide/Bushing	Nitronic 60
Valve	High temp stainless steel with plated stem
V-Band	CNC machined 304 stainless steel
Flanges	Fully-machined 304 stainless steel
Springs	17/7 PH stainless steel

Thermal Data	GVW-40 GVW-45 GVW-50 GVW-60
Max Thermal Stress (Non-Cooled)	270°C actuator body temp during thermal cycle test
Max Thermal Stress (Liquid-Cooled)	130°C actuator body temp during thermal cycle test
Max Exhaust Temp: Peak	Up to 1050°C



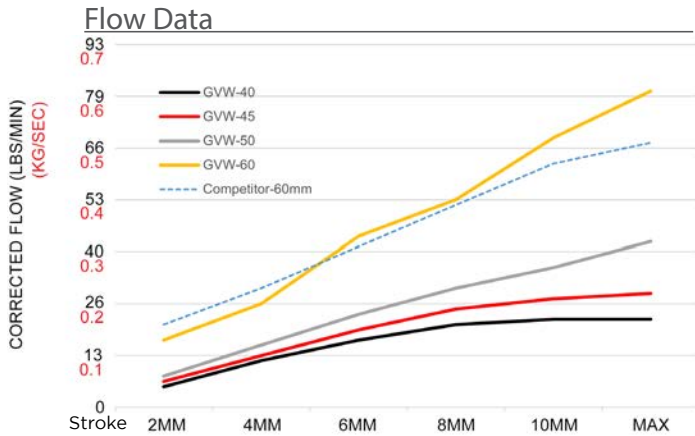

Actuation Durability Test Data

When researching and testing common shortfalls of wastegates, we observed how heat cycling and normal wear can rapidly change their actuation characteristics. Garrett engineers created GVW as a high flowing product with low degradation in performance over its lifespan.

Actuation data (opening and closing) in the chart was measured before and after extreme testing conditions. Results show the heat cycled GVW product maintains linear control of the wastegate as compared to the new product.

Precise actuation of the GVW provides accurate calibration settings and performance throughout the lifespan of the product. Accurate wastegates, allow for optimum performance of the turbocharger.

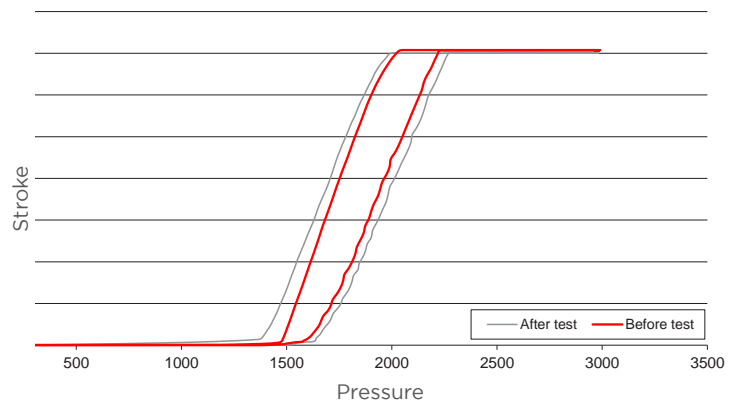

Spring Pressure Chart

										Base Pressure								
GVW-40	PSI	3	4	6	7	9	10	12	13	14.5	16	17	19	20	22	23	25	
	Bar	0.2	0.3	0.4	0.5	0.6	0.7	0.8	0.9	1	1.1	1.2	1.3	1.4	1.5	1.6	1.7	
	Red	x						x	x		x							
	Blue		x						x	x		x			x	x	x	
	Green			x				x	x				x				x	
	White				x				x					x	x			x
	Brown					x					x					x		
Purple						x					x	x	x	x		x	x	
GVW-45	PSI	3	4	6	7	9	10	12	13	14.5	16	17	19	20	22	23		
	Bar	0.2	0.3	0.4	0.5	0.6	0.7	0.8	0.9	1	1.1	1.2	1.3	1.4	1.5	1.6		
	Blue	x					x	x	x	x	x					x	x	
	Green		x						x			x	x		x			
	White			x		x		x		x				x			x	
	Brown				x		x	x	x		x	x						
	Purple					x							x	x	x	x		
Black											x	x	x	x	x	x		
GVW-50	PSI	3	4	6	7	9	10	12	13	14.5	16	17	19	20	22	23		
	Bar	0.2	0.3	0.4	0.5	0.6	0.7	0.8	0.9	1	1.1	1.2	1.3	1.4	1.5	1.6		
	Blue	x							x	x	x							
	Green		x						x						x			
	White			x		x		x		x				x			x	
	Brown				x		x	x	x		x	x						
	Purple					x							x	x	x	x		
Black											x	x	x	x	x	x		
GVW-60	PSI	3	4	6	7	9	10	12	13	14.5	16	17	19	20	22	23		
	Bar	0.2	0.3	0.4	0.5	0.6	0.7	0.8	0.9	1	1.1	1.2	1.3	1.4	1.5	1.6		
	Blue						x	x					x			x		
	Green	x							x					x				
	White		x							x					x	x		
	Yellow				x		x					x	x	x	x	x		
	Purple			x								x						
Aqua Blue					x		x	x	x	x	x	x	x	x	x	x		

Spring pressures are calculated based on a 1:1 boost/backpressure ratio. Actual intake manifold (boost) pressure can vary

GARRETT VENT | EXTERNAL WASTEGATES

Ancillary Part Chart | Tightening Torque Specs



Description	Tightening Torque Nm ft-lb	GVW-40	GVW-45	GVW-50	GVW-60
Kit: Air Fitting (Banjo Fitting, Bolt, 2 Crush Washers)	15 11		910477-0001		
Kit: Diaphragm (Diaphragm Assy, Valve Stem Nut)	10 7	910476-0001	910476-0002		910476-0003
Kit: Valve/Bushing (Valve,Bushing,Seal Washer,O-Ring,Valve Stem Nut,Seat)	10 7	910478-0001	910478-0002	910478-0003	910478-0004
Kit: V-Band Inlet (V-Band, Bolt, Locknut)	15 11	910475-0001	910475-0003	910475-0004	910475-0005
Kit: V-Band Outlet (V-Band, Bolt, Locknut)	15 11	910475-0002	910475-0001	910475-0003	910475-0006
Bolt, Actuator Body	5 4		Bolt Not Available		
Bolt, Actuator Cap	2.5 2.0		894537-0001		
Bolt, V-band	N/A		894540-0006		
Bolt, Banjo Fitting	15 11		Included In Air Fitting Kit		
Bushing	30 22		Included In Valve/Bushing Kit		
Fitting, Water 8mm	10 7		895520-0001		
Fitting, Plug Air 10mm	15 11		895519-0001		
Flange, Inlet Weld	N/A	894649-0003	894649-0001	894649-0007	894649-0005
Flange, Outlet Weld	N/A	894649-0004	894649-0002	894649-0008	894649-0006
Locknut, V-band	15 11		905694-0001		
Nut, Valve	10 7		Included In Valve/Bushing Kit		
Seat, Valve	N/A	894648-0002	894648-0001	894648-0004	894648-0003
Spring, Red (See Spring Chart For Spring Pressure)	N/A	898344-0001			
Spring, Blue (See Spring Chart For Spring Pressure)	N/A		898344-0002		
Spring, Green (See Spring Chart For Spring Pressure)	N/A		898344-0003		
Spring, White (See Spring Chart For Spring Pressure)	N/A		898344-0004		
Spring, Brown (See Spring Chart For Spring Pressure)	N/A		898344-0005		
Spring, Purple (See Spring Chart For Spring Pressure)	N/A		898344-0006		
Spring, Black (See Spring Chart For Spring Pressure)	N/A		898344-0008		
Washer, Crush 8mm	N/A		895518-0002		
Washer, Crush 10mm	N/A		895518-0001		

GVW Replacement Part Kits

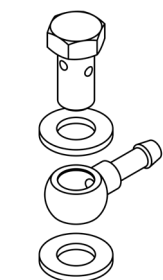

Air Fitting Kit

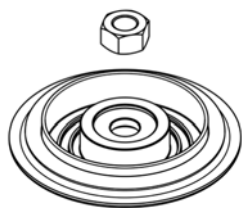

Diaphragm Kit



Valve/Bushing Kit

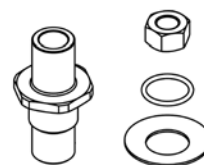

V-Band Inlet | Outlet Kit

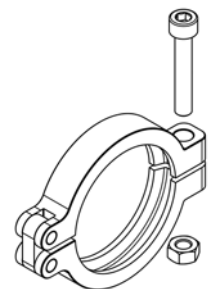

GARRETT VENT | BLOW-OFF VALVES

Garrett Vent | Blow-Off Valves release excess boost pressure from the charge pipe when the throttle is closed, preventing damage to the turbocharger and other engine components, ensuring smooth operation and prolonging the turbo's lifespan.



GARRETT VENT | BLOW-OFF VALVES

High-Flowing Blow-Off Valves for Performance Engines

Garrett Vent | Blow-Off Valves are created by the engineers that designed G-Series turbochargers and GVW Wastegates. GVB-50 is a high-flowing BOV with a 50mm valve, available in four striking color combinations. Select between vent to atmosphere (VTA) and recirculating (RCV) housing options. Delivering a maximum flow up to 350 CFM | .21kg/s (RCV) as a result of advanced CFD design software used to simulate, visualize, and quantify airflow before manufacturing started (GVB-50R RCV). The proprietary designed, high-temperature Nomex reinforced elastomer diaphragm ensures unmatched durability and fatigue resistance. A plated stem and bushing lower friction and improve wear resistance.

GVB Blow-Off Valves are set to 10 PSI of base pressure and offer configurable rates from 0.2 Bar | 3 PSI - 0.9 Bar | 13 PSI. Unlike the other products on the market, Garrett includes five springs enabling fine tuning of the pressure setting to optimize BOV performance, and therefore overall turbo system performance. The single vacuum port streamlines functionality. Every kit contains- all fasteners, springs, fittings, V-bands, clamps, and flanges. For pricing and availability please contact an authorized distributor.

Spring Settings: _____



GVB-50	Spring Settings								
	PSI 3	4	6	7	9	Base Pressure 10	12	13	
	Bar 0.2	0.3	0.4	0.5	0.6	0.7	0.8	0.9	
Red	x			x	x			x	
Blue		x				x			
Green				x				x	
White					x	x	x		
Brown			x				x	x	

Model	Part Number	Base Pressure	Color	Description
GVB-50A	914956-0001	10PSI	Red	Vent to atmosphere
GVB-50A	914956-0002		Blue	Vent to atmosphere
GVB-50A	914956-0003		Black	Vent to atmosphere
GVB-50A	914956-0004		Silver	Vent to atmosphere
GVB-50R	914959-0001		Red	Recirculating housing
GVB-50R	914959-0002		Blue	Recirculating housing
GVB-50R	914959-0003		Black	Recirculating housing
GVB-50R	914959-0004		Silver	Recirculating housing
GVB-50R	913283-0001	Outlet Hose Adapter 1.00" (25.4mm)		
GVB-50R	913283-0002	Outlet Hose Adapter 1.14" (29.0mm)		
GVB-50R	913283-0003	Outlet Hose Adapter 1.34" (34.0mm)		
GVB-50R	913283-0004	Outlet Hose Adapter 1.50" (38.1mm)		

Features:

- CFD tested for maximum flow and thermal efficiency
- Replaceable components to increase service life
- Robust design for easy diaphragm replacement
- 6061 Anodized aluminum actuator cover and fully-machined billet housing
- Maximum flow 350 CFM | .21kg/s for GVB-50R
- Four outlet adapters for the recirculating valve. Adapters sold separately
- Base pressure 0.7 Bar | 10 PSI (blue and white spring installed)
- Configurable springs settings include: 3 | 4 | 6 | 7 | 9 | 10 | 12 | 13 PSI
- Wrought Aluminum Alloy Weld Flange
- 17/7 PH Stainless Steel Springs
- Plated stem and bushing for lowered friction and wear resistance
- High temp nomex reinforced diaphragm
- Stainless steel fittings and fasteners



GVB-50R

GVB-50A

Flange Diagrams

- BOV flange dimensions interchangeable with Tial Q and QR

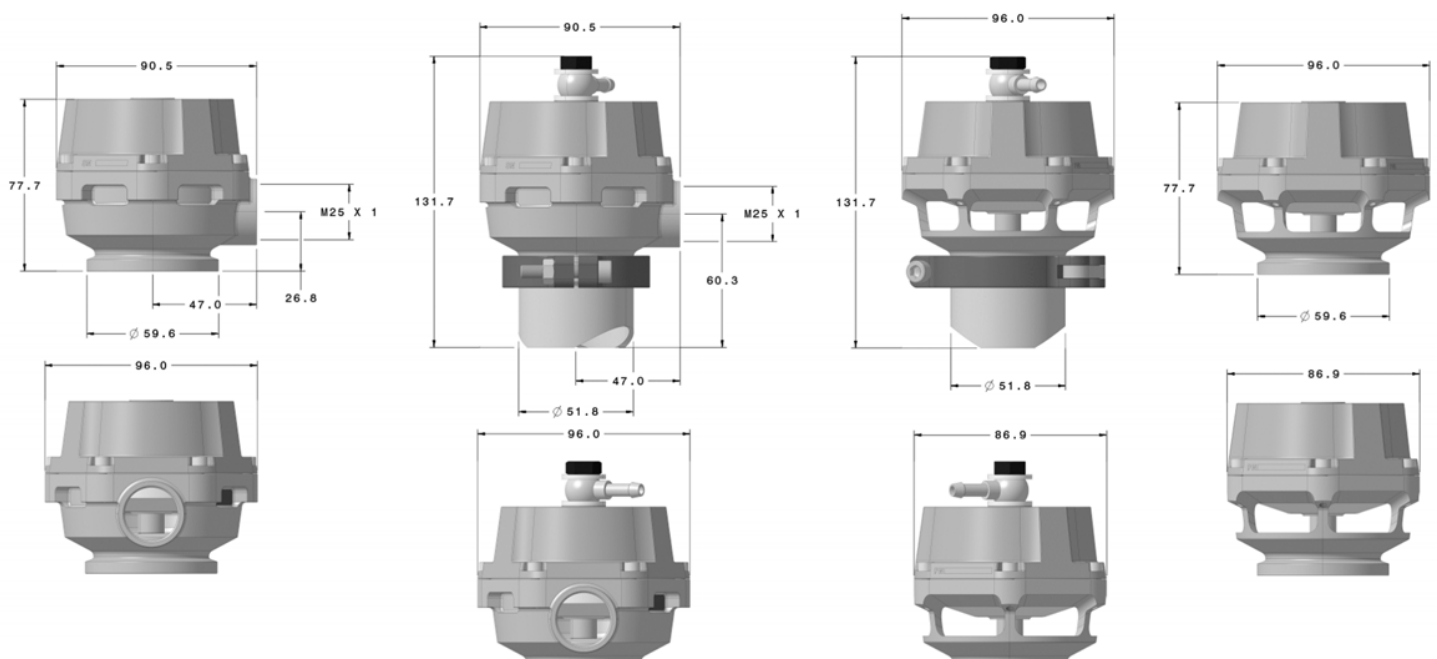



Garrett
ADVANCING MOTION

ACCESSORIES



Street Kit



Pro Kit

PN	Kit Type	Description	Speed Sensor	Harness	Gauge	Bolt
781328-0001	Street	GTX Gen II GTX GT GTW	Y	Y	Y	
781328-0002	Pro	GTX Gen II GTX GT GTW	Y	Y		
781328-0003	Street	G Series GTX55 Gen II GTX50 Gen II GTX47 Gen II	Y	Y	Y	Y
781328-0004	Pro	G Series GTX55 Gen II GTX50 Gen II GTX47 Gen II	Y	Y		Y

Speed Sensors: Select Garrett turbochargers come standard with a fully machined speed sensor port. Just remove the bolt and screw in the appropriate kit for your application. GT and GTX Gen I turbos can be machined by a shop of your choice to retrofit the speed sensor port. G-Series turbochargers utilize a new and easy to install sensor that does not need to be calibrated. GT/GTX speed sensor kits not applicable with G-Series turbochargers.

Maximum Performance

Comparing boost levels and shaft speed on a compressor map, you can determine the ideal operating conditions to ensure peak power over a wider operating range. All Garrett Turbocharger Speed Sensor Kits are compatible with data loggers to enhance engine tuning capability. In addition, the Garrett-branded gauge's maximum speed recall function will retain the highest wheel speed for five minutes for easy mapping. The data gained from the Garrett Turbocharger Speed Sensor Kit can be used to closely estimate the engine's flow behavior without a flow bench. Flow information is invaluable for determining if the turbocharger is reaching its maximum performance, for validating the turbo match, and for ensuring that it is not over speeding, allowing you to avoid potentially damaging operating conditions. This kit could even be used in conjunction with an aftermarket ECU to limit compressor speed. The Garrett Turbocharger Speed Sensor Kit will help you be sure you've got the correct turbo for your needs!

Easy To Use

The Garrett Turbocharger Speed Sensor works with any turbocharger to accurately determine compressor wheel speed. The instructions include detailed drawings of the exact machining specifications for all Garrett GT and GTX Gen I catalog turbochargers as well as general guidelines for other compressor housing types. G-Series / GTX55 Gen II / and GTX50 Gen II turbochargers use a new sensor that eliminates the calibration process. The Garrett Turbocharger Speed Sensor Kit includes all necessary wiring for easy installation and simple data logging.



Boost Gauge: The Garrett Mechanical Boost Gauge is the perfect addition to your interior for the important job of accurately monitoring your boost levels. The gauge has a sleek design and features a black face, white back lit numbers and a brushed aluminum ring. The gauge monitors boost from 30 Hg of vacuum to 30 psi of boost and is available in PSI and BAR configurations.

Boost Gauge Components: gauge, mounting bracket, hose, fitting, mounting hardware.

Boost Gauge PSI Part Number: 773326-0001

Boost Gauge BAR Part Number: 773326-0002



Divided V-Band Inlet Adapter: The Garrett divided V-Band adapter is for enthusiasts that are fabricating divided exhaust manifolds. This adapter mates perfectly with GT/GTX 30 and 35 divided V-Band turbine housings and has two 2" recessed orifices that feed into the flange.

Turbine Inlet Divided V-Band Adapter: Compatible with GT/GTX 30 & 35 divided turbine housings.

V-Band Adapter Part Number: 813444-0001



V-Band Turbine Outlet Adapter: The Garrett V-Band outlet adapter is for fabricating the turbo down pipe. This adapter mates perfectly with the G25 | G30 | G35 | GT30 | GT35 | GTX30 | GTX35 turbine housing outlet. It has a 3" recessed opening feeding the flange.

V-Band Adapter Part Number: 774175-0001



Adjustable Wastegate Bracket: The Garrett Adjustable Wastegate Bracket allows for a greater range of motion to set up the compressor outlet and wastegate can. The bracket also allows for redirection of the actuator to keep vacuum lines away from heat or sharp edges. The adjustable actuator bracket is available for use on GT25R, GT28R and GT30R turbochargers.

V-Band Adapter Part Number: 773151-0002



Actuator Kits: Garrett actuator kits are for use on internally wastegated turbine housings. These kits are designed to regulate shaft speed by venting exhaust gas out of the turbine housing.

PN	Model	Bar	Actuator Assembly
480009-0009	G GT GTX28	0.5	Actuator
480009-0006	G GT GTX28	1.0	*Rod end, jam nut, bracket, heat shield, retaining clip not included
480009-0010	G GT GTX28	1.5	



Kit PN	Model	Bar	Actuator Assembly Kit
700187-0001	T25		Actuator (fixed rod), bracket, heat shield.
759498-0001	GT GTX28	0.5	
759498-0007	GT GTX28	1.0	Actuator, rod end, jam nut, retaining clip.
759498-0005	GT GTX28	1.5	*Bracket and heat shield not included
759498-0004	GT GTX35R	0.8	
759498-0008	G25	0.5	G-Series V-band standard rotation, actuator, bracket and bolts, rod end, jam nut, retaining clip.
759498-0009	G25	1.0	*Heat shield not included
759498-0010	G25	1.5	
759498-0011	G25	0.5	G-Series V-band reverse rotation, actuator, bracket and bolts, rod end, jam nut, retaining clip.
759498-0012	G25	1.0	*Heat shield not included
759498-0013	G25	1.5	
759498-0014	G25	0.5	G-Series T4 standard rotation, actuator, bracket and bolts, rod end, jam nut, retaining clip.
759498-0015	G25	1.0	*Heat shield not included
759498-0016	G25	1.5	

•759498-0004 for use with turbine housing wastegate family 771300

G-SMART BLUETOOTH MODULE

Track your turbo's performance in real-time with the Garrett G-Smart Module. Transmit turbo speed and boost via Bluetooth with the free G-Smart application. This important data will allow users to see if they are operating the turbocharger within its recommended RPM limits to optimize durability and performance. The Garrett G-Smart Module is your turbocharger's ultimate companion, guiding you towards unparalleled performance.



PRISHOW
[FEATURED PRODUCTS]
SHOWCASE **TOP 3**
BEST ENGINE PRODUCT



Easy to Install and Setup

Say goodbye to tangled wires and tedious setups. Bluetooth functionality means no wires through the firewall for a quick, and easy installation. The plug-and-play harness accepts Garrett flange and threaded style speed sensors. Kits are available without a speed sensor for users who already have a speed sensor and with for those who don't have one. A 12V switched power and sufficient ground connection are all you need to get started. The Sensor Setup menu is loaded with existing Garrett Turbocharger part numbers, models, compressor wheel blade counts and max-rated turbo speed. Custom configurations can also be created for Garrett models without speed sensor ports or for non-Garrett manufactured turbochargers that utilize the same style speed sensors. For use with iOS and Android mobile devices. (Mobile device and mount not included.)

PN	Kit Description	Speed Sensor	Harness	Module
923586-0002	Module Harness Threaded Speed Sensor (GTX Gen II 28,30,35 and Custom Installation)	Threaded	Y	Y
923586-0003	Module Harness Flange Speed Sensor (G-Series GTX Gen II 47 50 55 PowerMax)	Flange	Y	Y
923586-0004	Module Harness	No	Y	Y



Flange Sensor Threaded Sensor

Analyze Turbo Speed and Boost Pressure

With the device paired and the car running, the mobile device screen will light up with live turbo speed and boost pressure (if connected) in a dynamic gauge and graphical format. The gauge display features a constant live data feed and has a marker that freezes on peak turbo speed.

The graph plot length can display up to 120 seconds of live data. The live data feed can be paused allowing users to review data points within the plot length with a touch of the screen. Users can connect the analog output to an external data logger/ECU for complete data logging.

WARNING

The use of any turbocharger product above maximum turbocharger speed is at the owner's risk and can result in damage and premature failure. To protect the turbocharger from overspeed when operating, a speed sensor can be installed into the compressor housing to monitor shaft speed.



FEATURES

- Bluetooth operation transmits data from the module to the G-Smart application
- Modern display with live turbo speed and boost pressure (if connected) readings
- Gauge sweep will transition color (G,Y,R) signaling the approach to max-rated turbo speed
- Marker on gauge sweep indicates peak turbo speed
- Display up to 120 seconds of turbo speed and boost data in easy-to-view graphical format
- Compatibility with both Android and iOS devices
- Easy installation and configuration with preset Garrett models and part numbers
- Create custom configurations for Garrett turbochargers without pre-machined speed sensor port or non-Garrett manufactured turbochargers
- Min/Max Turbo speed and boost pressure stored in app for future analysis

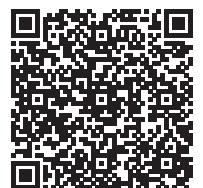

POWERMAX

PowerMax™ direct fit performance performance kits are engineered for increased engine performance while maintaining OEM direct fitment. With professional engine calibration and tuning, Garrett PowerMax will outperform the OEM product. These products are not approved for street use. Installation may affect the vehicle's safety, warranty, and operating license. For details, contact your vehicle's manufacturer or turbo kit distributor.



Important product information:

Garrett Performance Kits are professional aftermarket products only designed for certain racing vehicles driven on particular racing tracks and shall only be used on racing vehicles that will never be driven on public roads or highways. Garrett Performance Kits are not legal for use in vehicles on public roads or other roads to which public road law applies. Any vehicle modifications using Garrett Performance Kits are AT YOUR OWN RESPONSIBILITY and AT YOUR OWN RISK. Only use Garrett Performance Kits in compliance with all applicable laws, regulations and ordinances (including but not limited to emission, noise, operating license, performance, safety and type-approval aspects). A vehicle modification using Garrett Performance Kits may particularly affect or void a vehicle's warranty, operating license or type-approval. Moreover, only use Garrett Performance Kits in compliance with all applicable racing and racing track provisions. It is YOUR OWN RESPONSIBILITY AND RISK to ensure that your Garrett Performance Kit fits your vehicle and area of application. YOU MUST ENSURE LAWFUL AND SAFE OPERATIONS AT ANY TIME. You should particularly consult the owner's manual and service manual of your vehicle. You should also contact your vehicle's manufacturer to determine what effects modifications may have on important aspects such as safety, warranty, performance, etc. Only install and use Garrett Performance Kits if you have fully read and understood this important safety information and if you fully agree with the terms and conditions set forth therein.



2014 - 2018
VOLKSWAGEN | AUDI 2.0L
TSI MK7 STAGE 1 | STAGE 2



2020+
VOLKSWAGEN | AUDI | SKODA 2.0L
MK8 EA888 STAGE 1



2020+
VOLKSWAGEN GOLF R | AUDI 2.0L
TSI EA888 EVO4



2017 +
FORD ECOBOOST 3.5L
F-150 | RAPTOR | STAGE 2



2011 - 2021
FORD EVEREST | RANGER PX1 PX2 PX3
2011 - 2020
MAZDA BT-50



2007 - 2018
TOYOTA 4.5L
LAND CRUISER 1VD-FTV



2011 - 2017
FORD ECOBOOST 3.5L
F-150 | EXPEDITION | STAGE 1



2003 - 2011
VOLKSWAGEN | AUDI | 1.9L 2.0L
BEETLE | GOLF | JETTA | PASSAT | A3



2011 - 2016
CHEVROLET | GMC 6.6L
2500HD | 3500HD



1999.5 - 2007
FORD POWERSTROKE 7.3L
F-250 | F-350



1995.5 - 2007
FORD POWERSTROKE 6.0L
F-250 | F-350



2004.5 - 2010
CHEVROLET | GMC 6.6L
2500HD | 3500HD STAGE 1 STAGE 2



2013 - 2018
FORD ECOBOOST 2.0L
FOCUS ST | ESCAPE | FUSION | TAURUS



2014 - 2019
HOLDEN | CHEVROLET 2.8L
COLORADO XLDE DIESEL



2015+
FORD ECOBOOST 3.5L | 2.7L
F-150 | RAPTOR



2013 - 2018
FORD ECOBOOST 2.0L
FOCUS ST



2015+
SUBARU 2.0L
WRX



2011 - 2021
FORD EVEREST | RANGER PX1 PX2 PX3
2011 - 2020
MAZDA BT-50



2015 +
BMW 3.0L
F80 M3 | F82 / F83 M4



2016 +
HONDA 1.5L
CIVIC T/SI



2015 +
FORD ECOBOOST 2.3L
MUSTANG



Use Your Smart Phone
Camera To Scan



POWERMAX™ DIRECT FIT PERFORMANCE TURBOCHARGERS

Applications: Stage 1 Turbo Upgrade for F-150 3.5L | Expedition | Navigator 3.5L (2011 - 2017)

Part Numbers 881027-5001S | 881028-5001S | 881027-5002S | 881027-5002S

This Garrett PowerMax™ turbocharger upgrade for the Ford 3.5L EcoBoost engine platform is engineered to increase engine performance capability while maintaining OEM installation specifications. This direct drop-in stage 1 upgrade provides 22% more flow than OEM and will support up to 300HP* from each turbo. Improvements in efficiency and flow can be attributed to the light weight forged fully-machined compressor wheel. Boost response of this PowerMax turbocharger compared to OEM has not been tested. This turbocharger kit comes fully assembled and calibrated and is outline interchangeable with the OE hardware to ensure a perfect fit every time. Contact your local authorized Garrett distributor for additional information and pricing.

**Please refer to the legal notice on page 114 before purchasing this product.*

Part Number	Year	Model	Make	Engine	OEM PN	Notes:
881027-5001S	2011-2012	F-150	Ford	3.5L EcoBoost	CL3Z-6K682-C	Left Turbocharger
881028-5001S	2011-2012	F-150	Ford	3.5L EcoBoost	CL3Z-6K682-D	Right Turbocharger
881027-5002S	2013-2017	F-150	Ford	3.5L EcoBoost	DL3Z-6K682-E	Left Turbocharger
881028-5002S	2013-2017	F-150	Ford	3.5L EcoBoost	DL3Z-6K682-F	Right Turbocharger
881027-5002S	2015-2017	Expedition	Ford	3.5L EcoBoost	DL3Z-6K682-E	Left Turbocharger
881028-5002S	2015-2017	Expedition	Ford	3.5L EcoBoost	DL3Z-6K682-F	Right Turbocharger
881027-5002S	2015-2017	Navigator	Lincoln	3.5L EcoBoost	DL3Z-6K682-E	Left Turbocharger
881028-5002S	2015-2017	Navigator	Lincoln	3.5L EcoBoost	DL3Z-6K682-F	Right Turbocharger

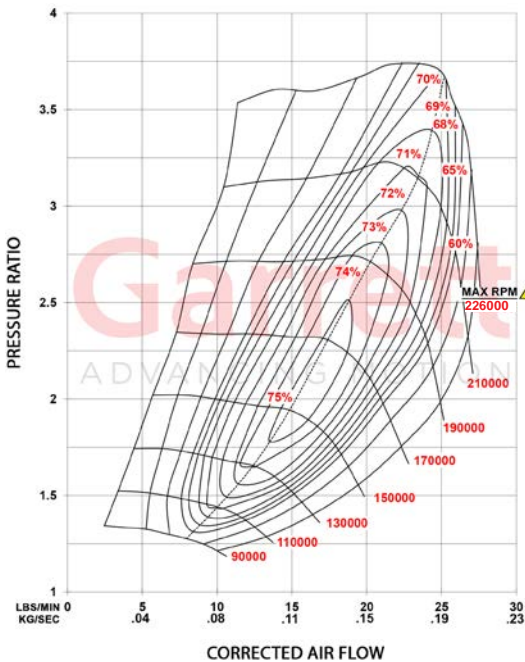

WARNING: Maximum allowable turbocharger speed is 226krpm. The use of this product above max turbocharger speed is at the owner's risk, and can result in damage and premature failure. To protect the turbocharger from overspeed when operating, a speed sensor port is machined into the compressor housing for the fitment of speed sensor part numbers 781328-0001 (includes sensor and gauge), and 781328-0002 (includes speed sensor). Speed sensors sold separately.

* Estimated Horsepower. Performance results of this product are highly dependent upon your vehicle's modifications and tuning/calibration. The horsepower numbers represented above are calculated based strictly on choke flow of the compressor map (total turbo capability), which represents the potential flywheel horsepower.



POWERMAX™ DIRECT FIT PERFORMANCE TURBOCHARGERS

Application: Stage 2 Turbo Upgrade For Ford Raptor | F-150 3.5L (2017 - 2021) Supports up to 700+HP**
Part Number 911984-5003S (Includes stock inlet adapter and o-ring. Does not include gaskets)

The Garrett PowerMax™ Stage 2 turbocharger upgrade for the 2017 - 2021 F-150 and F-150 Raptor platform is engineered to increase engine performance capability while maintaining OEM installation specifications. This direct drop-in Stage 2 upgrade provides 54% more flow than OEM and will support up to 700+ BHP*. Improvements in compressor efficiency and flow can be attributed to the 60mm fully-machined compressor wheel. Turbine flow is increased by 52% compared to OEM with a 50mm Inconel turbine wheel and larger 0.45 A/R turbine housing. This turbocharger kit comes fully assembled, calibrated, and is outline interchangeable with the OE hardware to ensure a perfect fit every time.

**Please refer to the legal notice on page 114 before purchasing this product.*

PowerMax Stage 2: 2017+ Ford F-150 F-150 Raptor				Compressor				Turbine		
Turbo PN	Bearing	Rotation	Actuation	Inducer	Exducer	Trim	A/R	Inducer	Exducer	Trim
911984-5003S	Journal	Standard	Electric	45mm	60mm	57	0.60	50mm	46mm	84
	Journal	Reverse	Electric	45mm	60mm	57	0.60	50mm	46mm	84

These turbochargers have received California Air Resources Board (CARB) certification. This certification (EO D-871) means our product has been tested in accordance with manufacturer/OEM specifications and meets the emissions standards set by the state of California and is approved for use in all 50 states when used as a drop-in replacement for factory equipment.

Features:

- Direct-fit Stage 2 upgrade (LH & RH Turbos)
- Compressor housing inlet (2.75") is larger than stock to allow for increased flow and optimized surge port
- Adapter for stock inlet tube included with turbo kit
- CARB Certified D-871
- 700+ BHP capability **
- Complete assembly with calibrated electric actuator
- Billet compressor wheel with 54% increased flow
- Inconel turbine wheel with 52% increased flow
- Modern compressor and turbine wheel aero
- Tuned ported shroud for optimal compressor surge and choke performance
- Speed sensor port: use PN 781328-0003 (street kit) or 781328-0004 (pro kit)
- Journal-bearing rotating group

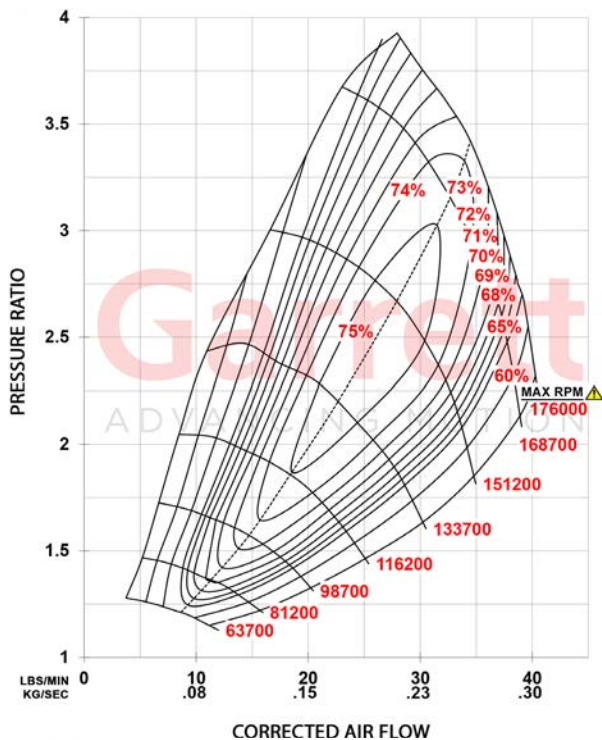

WARNING: Maximum allowable turbocharger speed is 176krpm. The use of this product above max turbocharger speed is at the owner's risk, and can result in damage and premature failure. To protect the turbocharger from overspeed when operating, a speed sensor port is machined into the compressor housing for the fitment of speed sensor part numbers 781328-0003 (includes sensor and gauge), and 781328-0004 (includes speed sensor). Speed sensors sold separately.

Stock inlet adapter (for use with the stock intake system) and the 2.75 inch adapter (for use with larger than stock intake systems) have different performance potentials.

** Estimated Horsepower. Performance results of this product are highly dependent upon your vehicle's modifications and tuning/calibration. The horsepower numbers represented above are calculated based strictly on choke flow of the compressor map (total turbo capability), which represents the potential flywheel horsepower.



POWERMAX™ DIRECT FIT PERFORMANCE TURBOCHARGERS

Application: Stage 1 & 2 TURBO UPGRADE FOR VW / Audi 2.0L TSI 2014 - 2021

Part Number: Stage 1 898199-5001W | Stage 2 898200-5001W

Garrett PowerMax™ turbocharger upgrades for the Volkswagen and Audi 2.0L TSI engine platform is engineered to increase engine performance while maintaining OEM installation specifications. Stage 1 (485 BHP*) and Stage 2 (600 BHP*) upgrades maximize efficiency and air flow compared to the OEM turbocharger. High temperature, Mar-M alloy turbine wheel and twin scroll stainless steel turbine housings are rated for up to 1050° C. These turbochargers are fully assembled with a calibrated electronic actuator and ancillary components for direct OEM fitment.

**Please refer to the legal notice on page 114 before purchasing this product.*

Part Number	Stage	Power	Model	Comp Ind	Comp Exd	Turb Ind	Turb Exd
898199-5001W	Stage 1	485HP 362kW	GT2260S	47mm	60mm	50mm	45mm
898200-5001W	Stage 2	600HP 447kW	G25-660	54mm	67mm	54mm	49mm

Stage 1 Features:

- Direct-fit stage 1 with 485HP | 362kW (flywheel) power capability (on-vehicle results)*
- Complete assembly with electronic actuator
- +17% compressor flow compared to IS38 turbo (stock Golf R)
- GTX Gen II compressor aerodynamics
- Mar-M alloy turbine wheel and twin scroll stainless steel turbine housing rated up to 1050° C
- Latest generation of journal bearing rotating group with 360° reinforced thrust bearing

Stage 2 Features:

- Direct-fit stage 2 with 600HP | 447kW (flywheel) power capability (on-vehicle results)*
- Complete assembly with electronic actuator
- +59% compressor flow compared to IS38 turbo (stock Golf R)
- G-Series compressor and turbine wheel aerodynamics
- Mar-M alloy turbine wheel and twin scroll stainless steel turbine housing rated up to 1050° C
- Latest generation of ball bearing rotating group

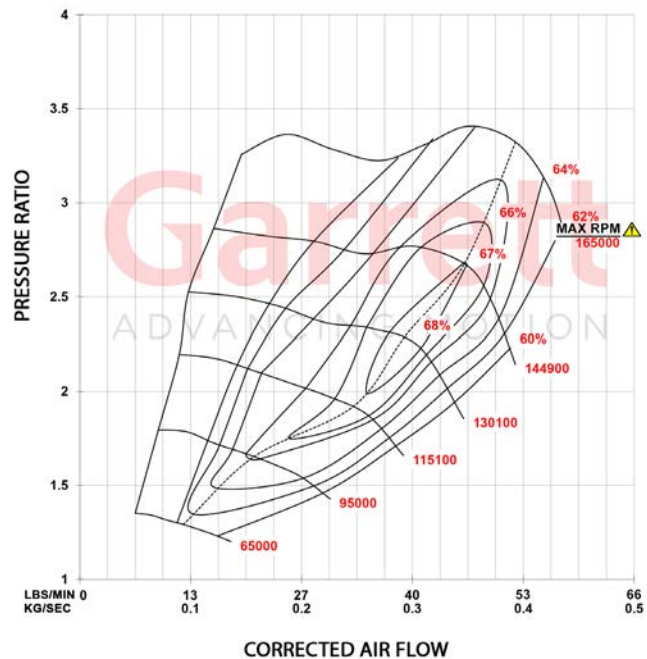
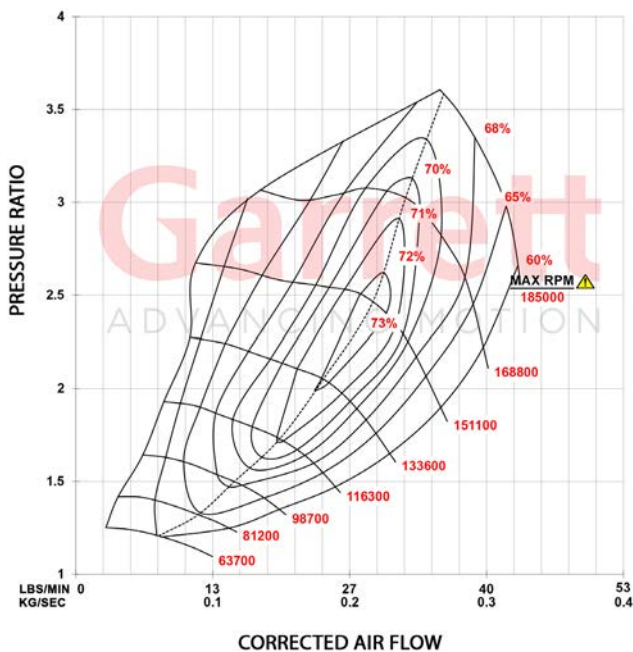

** Estimated Horsepower. Performance results of this product are highly dependent upon your vehicle's modifications and tuning/calibration. The horsepower numbers represented above are calculated based strictly on choke flow of the compressor map (total turbo capability), which represents the potential flywheel horsepower.

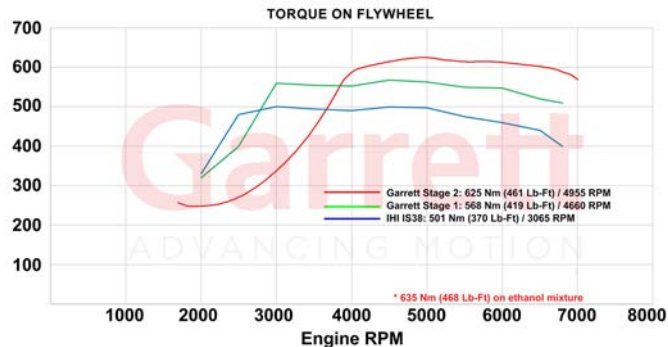
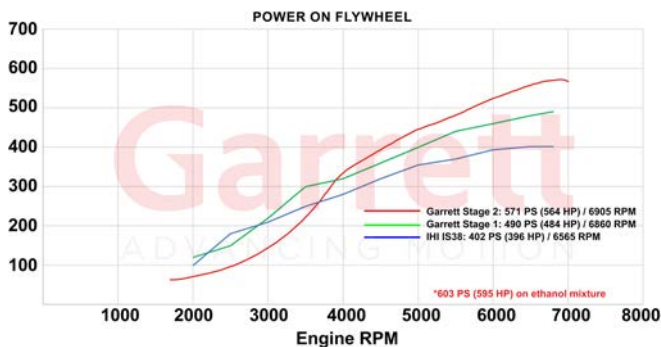

Make	Model	Year	Body & Trim	Engine	OEM Turbo
Audi	TT	2014 +	Base	2.0L L4 - Gas	IS20
Audi	TTS	2014 +	Base	2.0L L4 - Gas	IS38
Audi	A3	2015 - 18	Premium, Premium Plus, Prestige	2.0L L4 - Gas	IS20
Audi	A3 Quattro	2015 - 18	Premium, Premium Plus, Prestige	2.0L L4 - Gas	IS20
Audi	S3	2015 - 18	Premium Plus, Prestige	2.0L L4 - Gas	IS38
VW	Golf	2015	S, SE, SEL, Launch Edition	2.0L L4 - Gas	IS12
VW	Golf GTI	2015	Autobahn, S, SE	2.0L L4 - Gas	IS20
VW	Golf R	2015	Base	2.0L L4 - Gas	IS38
VW	Golf	2016	Base, S, SE, SEL	2.0L L4 - Gas	IS12
VW	Golf GTI	2016	Autobahn, S, SE	2.0L L4 - Gas	IS20
VW	Golf R	2016	Base	2.0L L4 - Gas	IS38
VW	Golf	2017	S, Wolfsburg Edition	2.0L L4 - Gas	IS12
VW	Golf Alltrack	2017	S, SE, SEL	2.0L L4 - Gas	IS12
VW	Golf GTI	2017	Autobahn, S, SE	2.0L L4 - Gas	IS20
VW	Golf R	2017	Base	2.0L L4 - Gas	IS38
VW	Golf	2018	S, SE, SEL	2.0L L4 - Gas	IS12
VW	Golf Alltrack	2018	S, SE, SEL	2.0L L4 - Gas	IS12
VW	Golf GTI	2018	Autobahn, S, SE	2.0L L4 - Gas	IS20
VW	Golf R	2018	Base	2.0L L4 - Gas	IS38
Audi	TT	2014-2018	Base	2.0L L4 - Gas	IS20
Audi	TT Quattro	2014-2018	Base	2.0L L4 - Gas	IS20
Audi	TTS Quattro	2014-2018	Base	2.0L L4 - Gas	IS38
Audi	S3	2013 - 16	Base	2.0L L4 - Gas	IS38
Audi	S3 (facelift)	2016 - 17	Base	2.0L L4 - Gas	IS38
Audi	SQ2 Quattro	2018-2020	Base	2.0L L4 - Gas	IS38
Seat	Leon Cupra	2014-2016	Base	2.0L L4 - Gas	IS20
Seat	Leon Cupra	2014-2018	280, 290	2.0L L4 - Gas	IS38
Seat	Leon Cupra (facelift)	2018-2020	290, 300, R	2.0L L4 - Gas	IS38
Cupra	Ateca	2018-2020	Base	2.0L L4 - Gas	IS38
Skoda	Octavia RS	2013-2016	Base	2.0L L4 - Gas	IS20
Skoda	Octavia RS (facelift)	2017-2020	Base	2.0L L4 - Gas	IS20
Skoda	Superb 4x4	2015-2019	Style, Ambition, SportLine	2.0L L4 - Gas	IS38
VW	Golf GTI	2013-2016	Base, Performance	2.0L L4 - Gas	IS20
VW	Golf R	2013-2016	Base	2.0L L4 - Gas	IS38
VW	Golf GTI	2016	Clubsport	2.0L L4 - Gas	IS38
VW	Golf GTI (facelift)	2017-2019	Base, Performance	2.0L L4 - Gas	IS20
VW	Golf GTI (facelift)	2019	TCR	2.0L L4 - Gas	IS38
VW	Golf R (facelift)	2017-2019	Base	2.0L L4 - Gas	IS38
VW	Passat 4MOTION	2018-2019	Base, Highline	2.0L L4 - Gas	IS38
VW	Arteon 4MOTION	2018-2020	Elegance, R-Line	2.0L L4 - Gas	IS38

OE Turbocharger Part Numbers

IS12 06K124713L
 IS20 06K145874M
 IS38 06K145722H

European Applications



WARNING: Maximum allowable turbocharger speed is 185krpm (Stage 1) and 165krpm (stage 2). The use of this product above max turbocharger speed is at the owner's risk, and can result in damage and premature failure. To protect the turbocharger from overspeed when operating, a speed sensor port is machined into the compressor housing for the fitment of speed sensor part numbers 781328-0003 (includes sensor and gauge), and 781328-0004 (includes speed sensor). Speed sensors sold separately.



POWERMAX™ DIRECT FIT PERFORMANCE TURBOCHARGER

Application: 2020+ Volkswagen Golf R | Audi | Cupra | 2.0L TSI EA888 EVO4 Engine

Part Number: 921474-5001S Supports up to 550BHP (410kW)

[Introducing the 2020+ Garrett PowerMax direct-fit turbocharger](#), the ultimate performance boost for your 2.0L TSI EA888 EVO4 engine. Whether you drive an Audi A3, a Golf R, or a Cupra Formentor, this upgrade will boost your driving experience to the next level.

This direct-fit turbocharger upgrade produced a stunning 520BHP (383kW) and 425ft-lb of torque (576Nm) on a conservative tune on the dyno. During flow testing, this performance turbocharger supplied +20% compressor flow, and +37% turbine flow compared to the OE turbo. Garrett's latest generation of compressor and turbine wheel technology provide maximum flow and efficiency to this turbocharger, all within the OEM footprint.

But that's not all. The turbine wheel is constructed of Mar-M alloy rated for temperatures up to 1050°C. The stainless steel, internally wastegated turbine housing is also rated for temperatures up to 1050°C, ensuring durability and reliability under extreme conditions. Additionally, the turbine housing wastegate channel has been optimized for higher flow and performance control. The PowerMax turbocharger also comes with a fully machined speed sensor port so you can track turbo speed in your data logger or in Garrett's new [G-Smart Bluetooth Module \(sold separately PN 923586-0003\)](#).

**Please refer to the legal notice on page 114 before purchasing this product.*

Turbocharger Reference Data:

Part Number	Power	Model	Comp Ind	Comp Exd	Turb Ind	Turb Exd
921474-5001S	550BHP 410kW	GT2563	51mm	63mm	58mm	50mm

Vehicle Applications:

Make	Model	Region	Year	Engine	OEM Turbo
VW	Golf R	North America	2022+	EA888 EVO4 - Gas	06Q145703C (EU) 06Q145703F 06Q145703G 06Q145703H
VW	Golf VIII GTI Clubsport	EMEA	2020+		
	T-ROC R 4Motion		2022+		
	Golf VIII R 4Motion		2020+		
	Golf VIII Variant TSI R 4Motion		2021+		
	Tiguan TSI R 4Motion		2020+		
Audi	A3 Limousine S3 Quattro		2020+		
	A3 Sportback S3 Quattro		2020+		
	SQ2		2021+		
	TTS Quattro		2021+		
	Roadster TTS Quattro		2020+		
Cupra	Formentor 2.0 TSI 4Drive		2020+		
	Leon Sportstourer 2.0 TSI 4Drive		2021+		
	Leon Sportstourer 2.0 TSI		2021+		
	Leon 2.0 TSI		2021+		
	Ateca 2.0 TSI 4Drive		2020+		

* Performance results of this product are highly dependent upon your vehicle's modifications and tuning/calibration. The horsepower numbers represented above are based on actual on-vehicle testing.

Compressor Map

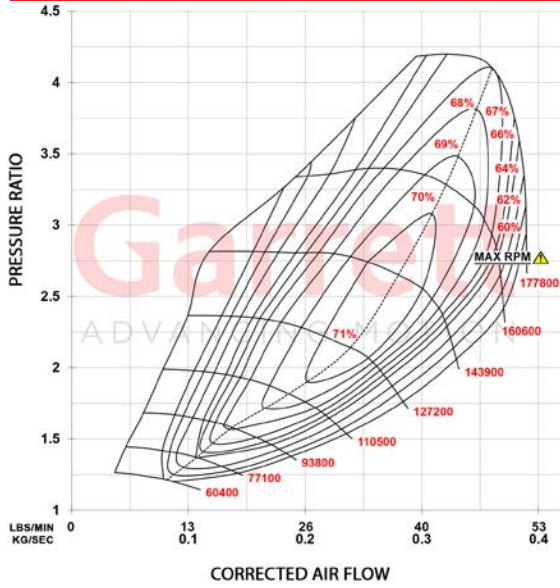

Exhaust Flow Chart

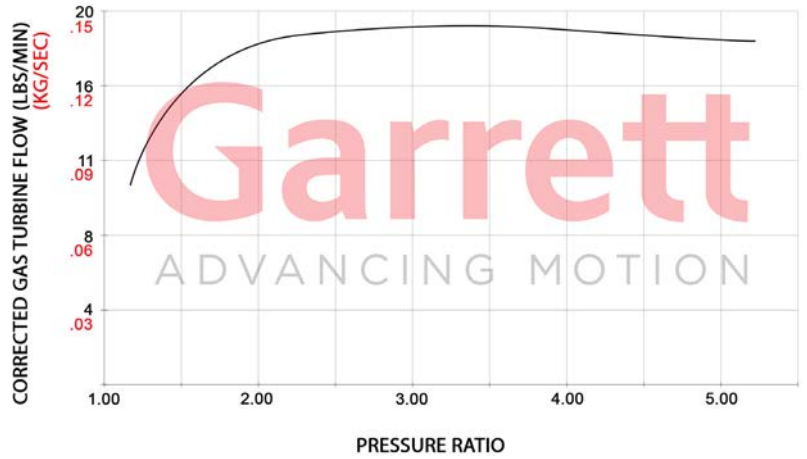

Features

- Complete assembly with calibrated electric actuator for OE fitment
- 550BHP | 410kW turbo capability (on-vehicle results 520BHP | 383kW - with conservative tune)
- +20% compressor flow compared to OE turbo
- +37% turbine flow compared to OE turbo
- Customized modern compressor wheel aero for application
- Modern gasoline turbine wheel aerodynamics constructed of Mar-M alloy rated for up to 1050°C
- Stainless steel turbine housing rated for up to 1050°C
- Fully machined speed sensor port
- Integrated thrust bearing - reinforced for application



On-Vehicle Test Data:

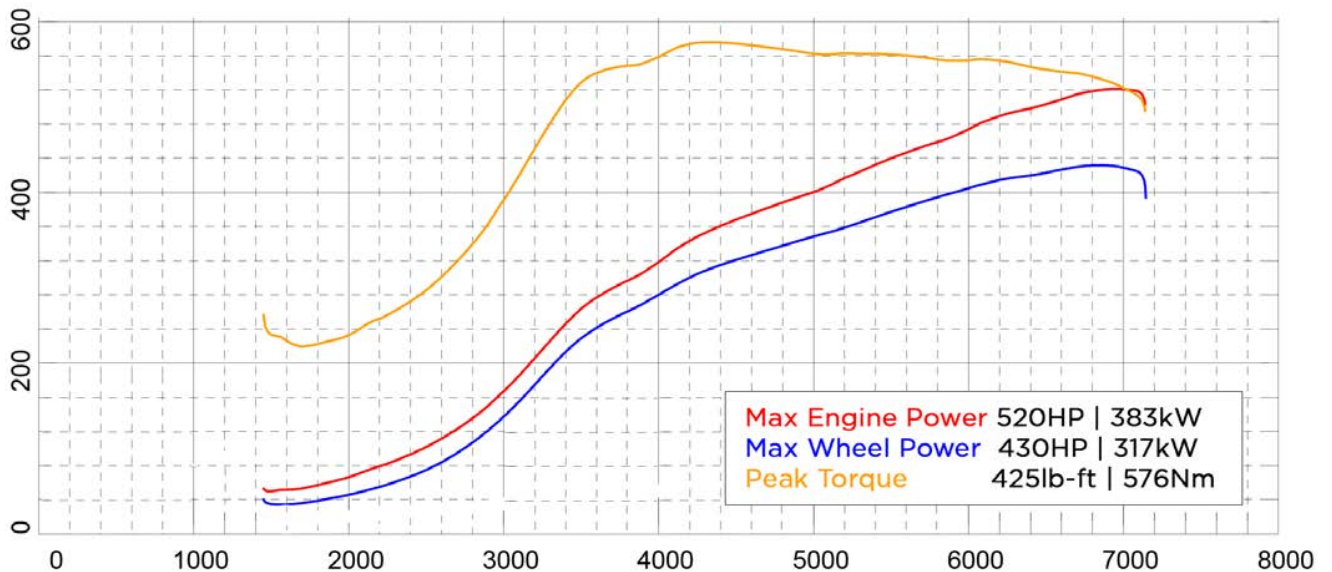

Vehicle Information:

- Location: Germany
- Golf R 2.0L TFSI (EA888 Evo4)
- Stock intercooler
- Custom downpipe
- Stock fuel system
- Fuel - 98 octane unleaded



WARNING: Maximum allowable turbocharger speed is 177.8krpm. The use of this product above max turbocharger speed is at the owner's risk, and can result in damage and premature failure. To protect the turbocharger from overspeed when operating, a speed sensor port is machined into the compressor housing for the fitment of speed sensor part numbers 781328-0003 (includes sensor and gauge), 781328-0004 (includes speed sensor), or [G-Smart Bluetooth Module with sensor \(PN 923586-0003\)](#). Sensor Kits sold separately.

* Performance results of this product are highly dependent upon your vehicle's modifications and tuning/calibration. Horsepower numbers represented above are based on actual on-vehicle testing.



POWERMAX™ DIRECT FIT PERFORMANCE TURBOCHARGER
Application: 2020+ Volkswagen | Audi | Skoda | Cupra | Seat 2.0L EA888 Engine
Part Number: 917056-5002S Supports up to 447BHP (333kW)

Introducing the Garrett PowerMax™ turbocharger upgrade for the 2.0L EA888 Evo4 engine platform. Engineered by enthusiasts, for enthusiasts, this turbocharger upgrade isn't just about boosting your engine's capabilities, it's also about packaging it into your vehicle's existing OEM setup. This complete turbocharger with electronic actuator can help the engine produce up to an impressive 447BHP (333 kW), as proven by on-vehicle results.

GTX Gen II compressor aerodynamics increase turbocharger flow by a staggering 32% compared to the OEM turbo. Embrace the future of power with the high-temperature Mar-M alloy turbine wheel, paired with state-of-the-art turbine aerodynamics and a robust twin scroll stainless steel turbine housing capable of withstanding up to 1050°C of heat. Elevate your driving game, and experience performance like never before with PowerMax™.

**Please refer to the legal notice on page 114 before purchasing this product.*

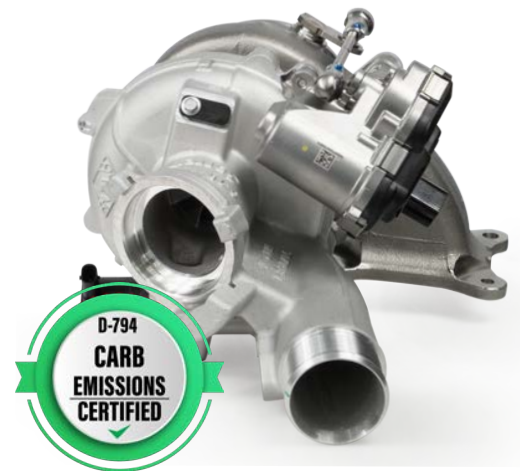

Part Number	Power	Model	Comp Ind	Comp Exd	Turb Ind	Turb Exd
917056-5002S	447BHP (333kW)	GT2260S	47mm	60mm	50mm	45mm

Vehicle Applications:

Make	Model	Region	Year	Engine	OEM Turbo
VW	Golf GTI	North America	2022+	2.0L EA888 Evo4 L4 - Gas	06Q145702B
VW	Golf GTI	Europe	2020+		
VW	Tiguan 2.0 TSI		2020+		
Audi	Q3 45 TFSI 2.0		2021+		
Audi	TT 45 TFSI 2.0		2020+		
Skoda	Kodiaq RS TSI 4x4		2021+		
Skoda	Octavia RS		2020+		
Cupra	Leon 2.0 TSI		2021+		
Cupra	Formentor 2.0 TSI		2021+		
Seat	Tarraco 2.0 TSI		2021		

• Garrett is the OEM turbocharger for this application. For regions and applications not listed above please reference the OEM turbo part number for fitment.

* Performance results of this product are highly dependent upon your vehicle's modifications and tuning/calibration. The horsepower numbers represented above are based on actual on-vehicle testing.

Compressor Map

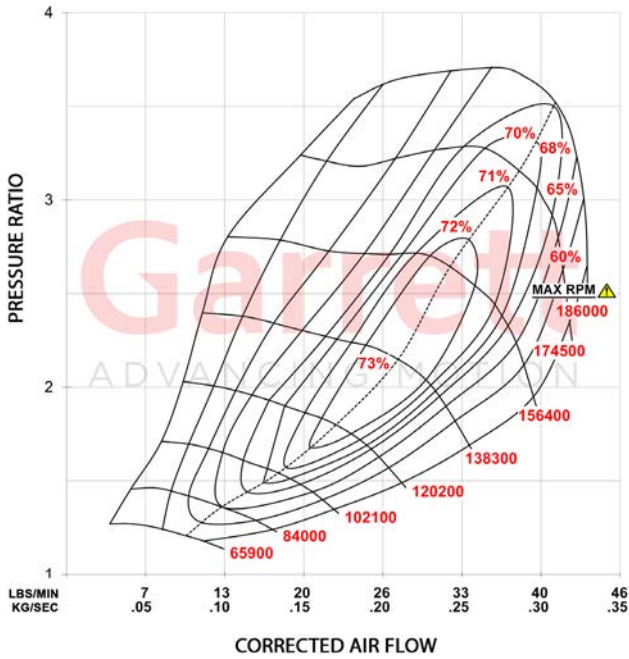

Exhaust Flow Chart

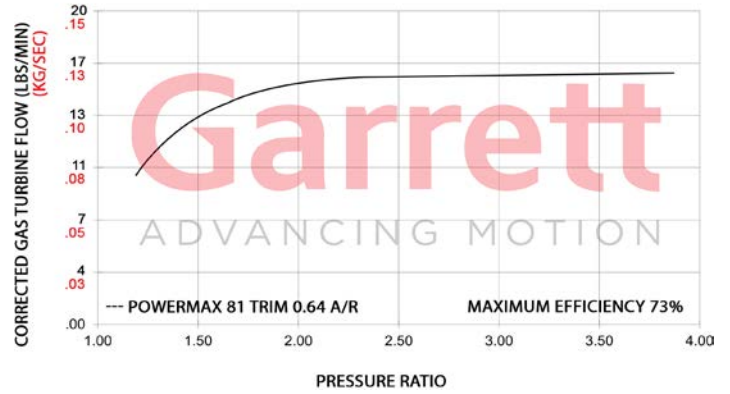

Features:

- Complete assembly with electronic actuator
- +32% compressor flow compared to the OEM turbo
- GTX Gen II compressor aerodynamics
- Mar-M alloy turbine wheel and twin scroll stainless steel turbine housing rated up to 1050° C
- Latest generation of journal bearing rotating group with 360° reinforced thrust bearing
- Direct-fit turbo with 447BHP (333kW) capability (on-vehicle results)*
- +50% turbine flow compared to OEM turbo

On-Vehicle Test Data: VW Golf GTI 2.0L TFSI (EA888 Evo4)

Vehicle Modifications:

- Location: Germany
- GTI 2.0L TFSI (EA888 Evo4)
- 917056-5002S Turbocharger
- Stock intercooler
- Custom downpipe
- Stock fuel system
- Fuel - 98 octane unleaded

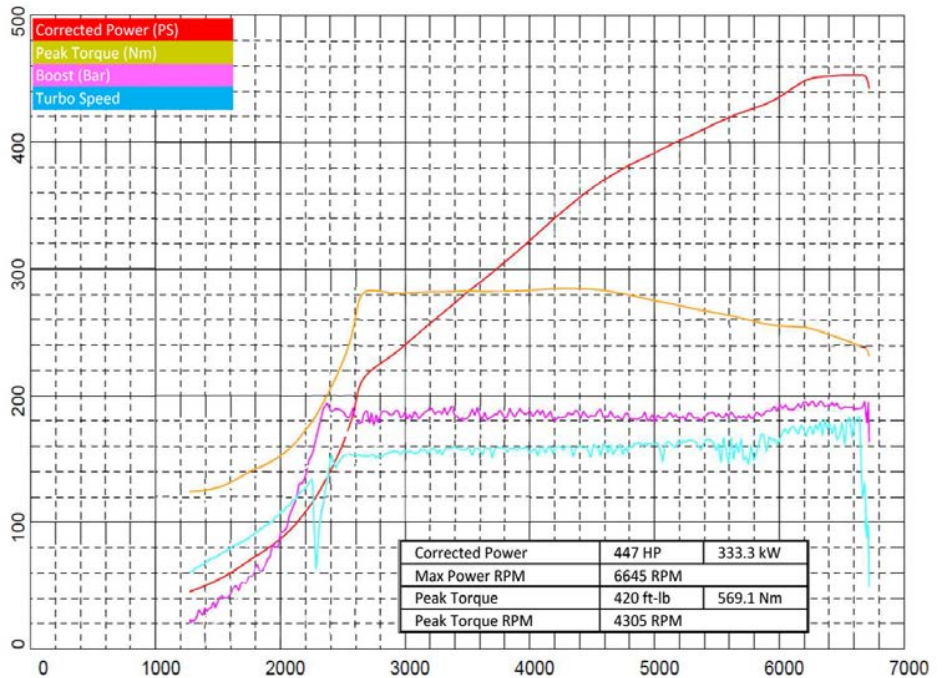

WARNING: Maximum allowable turbocharger speed is 186krpm. The use of this product above max turbocharger speed is at the owner's risk, and can result in damage and premature failure. To protect the turbocharger from overspeed when operating, a speed sensor port is machined into the compressor housing for the fitment of speed sensor part numbers 781328-0003 (includes sensor and gauge), and 781328-0004 (includes speed sensor). Speed sensors sold separately.



POWERMAX™ DIRECT FIT PERFORMANCE TURBOCHARGER

Applications: Stage 1 Turbo Upgrade For Ford 2.0L EcoBoost (2013 - 2018) Focus ST | Escape | Kuga | Fusion | Taurus | Lincoln
Part Number: 886195-5001S

The Garrett PowerMax™ Stage 1 turbocharger upgrade for the 2013 - 2018 2.0L Ford EcoBoost engine platform is engineered to increase engine performance capability while maintaining OEM installation specifications. This direct drop-in turbocharger provides up to 16% more flow than OEM and will support up to 350 BHP* (260kW). Improvements in compressor efficiency and flow can be attributed to the 52mm fully-machined compressor wheel with advanced aero design. Inconel alloy turbine wheel and stainless steel turbine housings are rated for up to 950° C. This turbocharger kit comes fully assembled, calibrated, and is outline interchangeable with the OE hardware to ensure a perfect fit every time. Contact your local authorized Garrett® distributor for additional information and pricing.

**Please refer to the legal notice on page 114 before purchasing this product.*

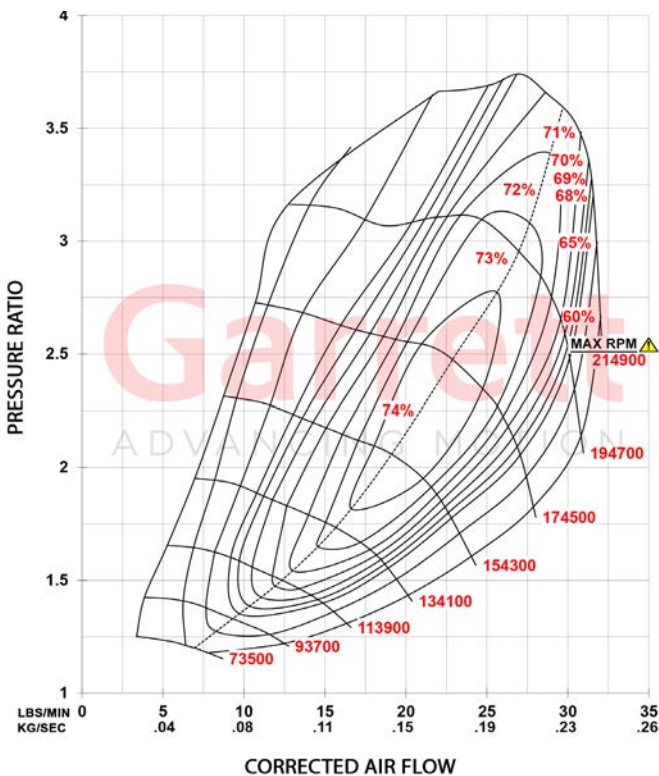

Part Number		886195-5001S
Model	Year	Body & Trim
Escape / Kuga	2014 - 2016	SE, Titanium
Focus	2013 - 2018	ST
Fusion	2013 - 2016	SE, Titanium
Police Sedan	2014 - 2018	Base
Taurus	2013 - 2017	Limited, SE, SEL
MKC	2015 - 2017	Base, Black Label, Premiere, Reserve, Select
MKT	2016	Base
MKZ	2013 - 2016	Base, Black Label
Engine	Type	2.0L EcoBoost
	Fuel	Gas
	Cylinders	4



WARNING: Maximum allowable turbocharger speed is 214.9krpm. The use of this product above max turbocharger speed is at the owner's risk, and can result in damage and premature failure. To protect the turbocharger from overspeed when operating, a speed sensor port is machined into the compressor housing for the fitment of speed sensor part numbers 781328-0001 (includes sensor and gauge), and 781328-0002 (includes speed sensor). Speed sensors sold separately.

* Estimated Horsepower. Performance results of this product are highly dependent upon your vehicle's modifications and tuning/calibration. The horsepower numbers represented above are calculated based strictly on choke flow of the compressor map (total turbo capability), which represents the potential flywheel horsepower.



POWERMAX™ DIRECT FIT PERFORMANCE INTERCOOLER

Application: 2013 - 2018 2.0L Ford Focus ST

Part Number: 880736-6001

The Garrett direct fit Ford Focus ST performance charge air cooler boasts a 115% larger core that helps reduce intake manifold temperatures by an average of 11 °F (6.1 °C) based on OBD II data. Optimized end tanks improve air flow through the core. This performance intercooler showed an increase of up to 25 HP (19 kW) and 9 lb-ft (12 N-m) of torque compared to OE during back to back dyno comparisons in a wind tunnel which generates air velocity that matches vehicle speed. During testing the heat saturation point increased from 4 dyno pulls to 8 dyno pulls.

This direct fit performance intercooler installs in 1.5 hour and reuses the stock bolts, hoses, and clamps. Removal of the OE grill shutters required. For more information including Installation instructions please visit our website: www.garrettmotion.com/racing-and-performance/performance-catalog/intercoolers/

Features:

- Supports up to 670 HP (499 kW)
- 115% larger core than stock
- Installs in stock location
- Up to 25 HP (19 kW) and 9 lb-ft (12 N-m) of torque
- Average 11 °F (6.1 °C) reduction in intake temperature based on OBD II data
- Integrated drain plug to evacuate condensation
- Cast aluminum end tanks
- Advanced offset fin design
- Bar-and-plate construction

Part Number		880736-6001
Vehicle	Make	Ford
	Model	Focus ST
	Year	2013-2018
Engine	Type	2.0L
	Fuel	Gas
Weight	23 lbs / 10.4 kg	
Size Specs	26.3" x 4.3" x 7.8"	
	668mm x 109mm x 198mm	

*** Important:** For customers outside of North America, MAP sensor BV61-9F479-AA must be purchased separately and used for installation to ensure a proper fit





POWERMAX™ DIRECT FIT PERFORMANCE INTERCOOLER

Application: 2011-2021 Ford Ranger PX1 PX2 PX3 | Everest | 2011-2020 Mazda BT-50

Part Number: 881649-6001

The Garrett direct fit performance charge air cooler for the Ford Ranger and Mazda BT50 boasts a 218% larger core that helps reduce intake manifold temperatures by an average of 32 °C based on test data. Optimized end tanks improve air flow through the core. This direct fit performance intercooler installs in 2.0 hours and reuses the stock bolts, hoses, and clamps.

This direct fit performance intercooler installs in 1.5 hour and reuses the stock bolts, hoses, and clamps. Removal of the OE grill shutters required. For more information including Installation instructions please visit our website: www.garrettmotion.com/racing-and-performance/performance-catalog/intercoolers/

Features:

- Supports up to 499 kW
- 218% larger core than stock
- Installs in stock location
- Cast aluminum end tanks
- Advanced offset fin design
- Bar-and-plate construction

Part Number		881649-6001	
Vehicle	Make	Ford	Mazda
	Model	Ranger PX1 PX2 PX3 Everest	BT-50
	Year	2011-2021	2011-2020
Engine	Type	3.2L 2.2L 2.0L	
	Fuel	Diesel	
Weight	12.56 kg		
Size Specs	680mm x 101mm x 260mm		



*** Important:** For applications outside of Australia, please contact your local distributor to ensure drop-in fitment as products may need modification or additional hoses/clamps.



POWERMAX™ DIRECT FIT PERFORMANCE TURBOCHARGER

Applications: Stage 1 Turbo Upgrade for 2011-2021 Ford Ranger PX1 PX2 PX3 | Everest| 2011-2020 Mazda BT-50

Supports up to 172kW*

Part Number: 880862-5001W

This Garrett PowerMax™ direct fit turbocharger is designed for the 3.2L Duratorq 5 cylinder diesel engine platform found in the 2011-2021 Ford Ranger PX1 PX2 PX3 | Everest and the 2011-2020 Mazda BT-50. The forged, fully machined compressor wheel designed for the GTX Gen II product line increases flow by 20% over the OE wheel. With the correct engine calibration, this enables the engine to be tuned up to 172kW from OE standard 147kW. All Garrett PowerMax™ direct fit turbochargers are outline interchangeable with the OE turbocharger ensuring a perfect fit every time.

**Please refer to the legal notice on page 114 before purchasing this product.*

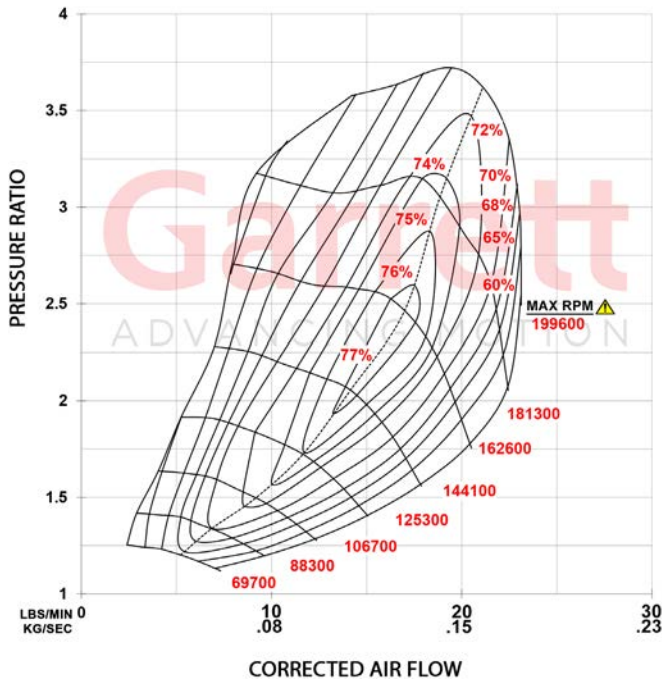

Part Number		880862-5001W **	
Turbo	Replaces OEM part numbers	798166-0006 (5006S) 812971-0006 (5006S) 853333-5001S	
	Vehicle	Make	Ford Mazda
		Model	Ranger PX1 PX2 PX3 Everest
Year	2011 - 2021	2011 - 2020	
Engine	Type	Duratorq 3.2 / Powerstroke 3.2	
	Fuel	Diesel	
	Emissions	Euro V	
	Cylinders	5	

** Includes gasket kit

Features:

- GTX Gen II compressor wheel aerodynamics
- Wider compressor map for improved performance
- 20% more flow than the OE turbocharger



WARNING: Maximum allowable turbocharger speed is 199.6krpm. The use of this product above max turbocharger speed is at the owner's risk, and can result in damage and premature failure. To protect the turbocharger from overspeed when operating, a speed sensor port is machined into the compressor housing for the fitment of speed sensor part numbers 781328-0001 (includes sensor and gauge), and 781328-0002 (includes speed sensor). Speed sensors sold separately.

* Estimated Horsepower. Performance results of this product are highly dependent upon your vehicle's modifications and tuning/calibration. The horsepower numbers represented above are calculated based strictly on choke flow of the compressor map (total turbo capability), which represents the potential flywheel horsepower.



POWERMAX™ DIRECT FIT PERFORMANCE INTERCOOLER

Application: 2015+ Ford F-150 and Raptor 3.5L EcoBoost
Supports Up To 750 Horsepower | C.A.R.B Certified ✓
Part Number: 870702-6001

The Garrett direct fit F-150 charge air cooler boasts an 83% larger core than stock to provide up to 40 °F reduction in air temperature and up to 30% reduction in pressure drop. Optimized end tanks improve air flow through the core. This direct fit performance intercooler is easily installed and can support up to 750 horsepower all while reusing the stock bolts, hoses, and clamps.

This direct fit performance intercooler installs in 2.5 hours and reuses the stock bolts, hoses, and clamps. Removal of the OE grill shutters required. For more information including Installation instructions please visit our website: www.garrettmotion.com/racing-and-performance/performance-catalog/intercoolers/

Features:

- Supports up to 750 horsepower
- C.A.R.B Certified (EO# D-794)
- 83% larger core than stock
- Installs in stock location
- +16 horsepower at temperature saturation
- Up to 40 °F reduction in temperature
- Integrated drain plug to evacuate condensation

Part Number		870702-6001
Vehicle	Make	Ford
	Model	F-150
	Year	2015+
Engine	Type	3.5L / 2.7L
	Fuel	Gas
Size Specs	21" x 5.32" x 9.43"	





POWERMAX™ DIRECT FIT PERFORMANCE TURBOCHARGER

Application: Stage 1 Turbo Upgrade For 1.9L | 2.0L VW TDI Engines

VW 1.9L TURBO UPGRADE

Part Number: 778445-5002S 1.9L (175hp*)

The Garrett GT1749V is the first performance upgrade / replacement turbocharger available to the aftermarket for Volkswagen 1.9L TDI BEW Engines. The GT1749V comes equipped with a smart actuator, an industry exclusive, and a position sensor, which enables the turbocharger to communicate automatically with the Engine Control Unit (ECU). The kit is easy to install and suitable as a performance upgrade or replacement turbocharger. The Garrett VW TDI Kit also promotes a longer turbo and engine life span and increased reliability by lowering exhaust gas temperatures.

VW 2.0L TURBO UPGRADE

Part Number: 838946-5001S 2.0L (190hp*)

The Garrett GTA1749V is a performance upgrade / replacement turbocharger available to the Aftermarket for Volkswagen 2.0L TDI BKD/BKP/AZV engines. The GTA1749V comes equipped with a larger compressor wheel for increased flow and bolts directly to the stock engine manifold flange. The turbo is easy to install and suitable as a performance upgrade or replacement turbocharger. The Garrett VW TDI turbo also promotes a longer turbo and engine life span and increased reliability by lowering exhaust gas temperatures.

**Please refer to the legal notice on page 114 before purchasing this product.*

Volkswagen TDI 1.9L 2.0L Upgrade	Turbo PN	HP*	Compressor				Turbine			
			Inducer	Exducer	Trim	A/R	Inducer	Exducer	Trim	A/R
VW 1.9L TDI (BEW Engine) VNT	778445-5002S	175	36mm	49mm	55	0.46	43mm	38mm	76	0.61
VW 2.0L TDI (BKD Engine) VNT	838946-5001S	190	36mm	49mm	55	0.46	43mm	36mm	70	0.61

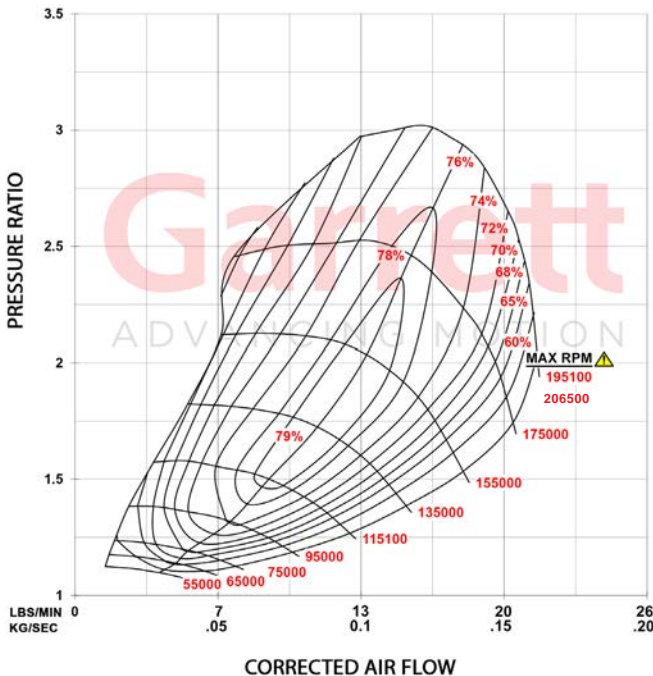

Replaces VW OE Part Numbers: 03G 253 010 J & 03G 253 010 J V100

- Vehicles: 2.0L TDI BKD/BKP/AZV engines
 2003.10-2009.07 - Golf V Mk5 A5 (PQ35) (typ 1K)
 2005.08-2011.05 - Jetta A5 (PQ35) (typ 1K)
 2003.08-2010.05 - Touran (typ 1T) - [AZV for 136 HP]
 2005.09-2010.05 - Passat B6 (typ 1T) - BKP
 2004.02-2010.05 - Skoda Octavia Mk2 (typ 1Z)
 2nd gen. [AZV fo 136HP]
 2009.01-2010.03 - Skoda Superb B6 (typ 3T) [BKD EA188]
 2005.07-2011.09 - Leon Mk2 (typ 1P)
 2004.03-2011.09 - Seat Altea
 2004.04-2009.05 - Seat Toledo 3
 2003.08-2007.05 - Audi A3 (Typ 8P)

Replaces VW OE Part Numbers: 038 253 019 S & 038 253 014 E Model: KP39 (3K)

- Vehicles: 2003.05 - 2006 Volkswagen Beetle TDI
 2003.05 - 2006 Volkswagen Golf TDI
 2003.05 - 2005 Volkswagen Jetta TDI



WARNING: Maximum allowable turbocharger speed is 206.5krpm. The use of this product above max turbocharger speed is at the owner's risk, and can result in damage and premature failure. To protect the turbocharger from overspeed when operating, a speed sensor port can be machined into the compressor housing for the fitment of speed sensor part numbers 781328-0001 (includes sensor and gauge), and 781328-0002 (includes speed sensor). Speed sensors sold separately.

* Estimated. Performance results of this product are highly dependent upon your vehicle's modifications and tuning/calibration. The horsepower numbers represented above are calculated based strictly on choke flow of the compressor map (total turbo capability), which represents the potential flywheel horsepower.



POWERMAX™ DIRECT FIT PERFORMANCE TURBOCHARGER

Application: Stage 1 | 2 Turbo Upgrade For 2004.5 - 2009 6.6L Duramax Engines

Stage 1 | 2004.5-2009 Chevy / GMC 2500, 3500
Part Number 773540-5001s (590HP*)

Stage 2 | 2004.5-2009 Chevy / GMC 2500, 3500
Part Number 773542-5001s (630HP*)

The Duramax Stage 1 turbocharger kit features Garrett patented Advanced Variable Nozzle Turbine AVNT™ design for increased compressor and turbine flow. The GT Series wheel design ensures top performance, lower back pressure and reduces intake and exhaust gas temperatures. The unique design features nine movable vanes which significantly increase turbine efficiency and improve engine performance from idle launch through peak torque. Patented integral electro-hydraulic actuation and proportional solenoid allow for infinitely variable control. Suitable as a performance upgrade or replacement for original equipment. Outline interchangeable with the OE turbo for a perfect fit each and every time.

The Duramax Stage 2 turbocharger kit features Garrett patented Advanced Variable Nozzle Turbine AVNT™ design for increased compressor flow and turbine flow. Utilizes nine movable vanes which significantly increase turbine efficiency and improve engine performance from idle launch through peak torque. Patented integral electro-hydraulic actuation and proportional solenoid for infinitely variable control. Larger compressor trim (52), plus larger GT40 turbine wheel and vanes. Outline interchangeable with the OE turbo for a perfect fit each and every time.

**Please refer to the legal notice on page 114 before purchasing this product.*

Chevy GMC Duramax Upgrade	Turbo PN	HP*	Compressor				Turbine			
			Inducer	Exducer	Trim	A/R	Inducer	Exducer	Trim	A/R
Duramax 6.6L 2004.5-2009 Stage 1	773540-5001S	590	65mm	94mm	48	0.58	73mm	67mm	78	0.90
Duramax 6.6L 2004.5-2009 Stage 2	773542-5001S	630	68mm	94mm	52	0.58	77mm	68mm	79	0.90

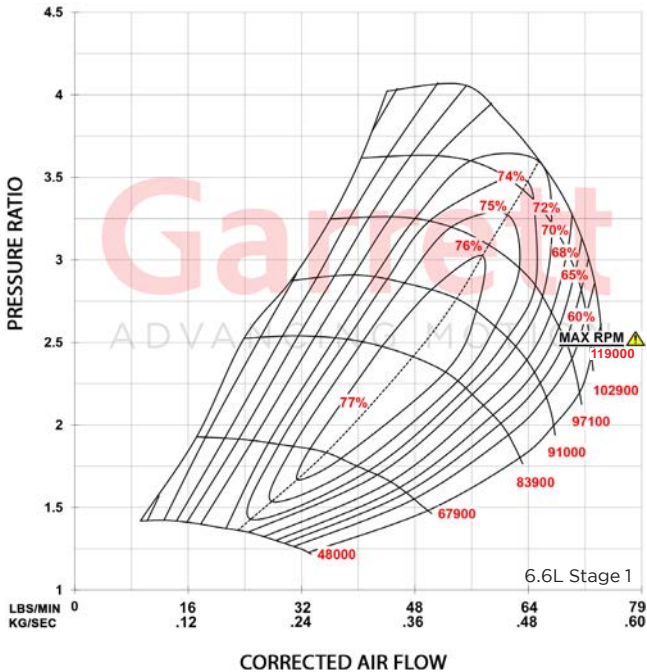

WARNING: Maximum allowable turbocharger speed is 119krpm. The use of this product above max turbocharger speed is at the owner's risk, and can result in damage and premature failure. To protect the turbocharger from overspeed when operating, a speed sensor port can be machined into the compressor housing for the fitment of speed sensor part numbers 781328-0001 (includes sensor and gauge), and 781328-0002 (includes speed sensor). Speed sensors sold separately.

* Estimated. Performance results of this product are highly dependent upon your vehicle's modifications and tuning/calibration. The horsepower numbers represented above are calculated based strictly on choke flow of the compressor map (total turbo capability), which represents the potential flywheel horsepower.



POWERMAX™ DIRECT FIT PERFORMANCE TURBOCHARGER

Application: Stage 1 Turbo Upgrade For (2014 - 2019) General Motors (Holden, Chevrolet) Colorado 2.8L XLDE
Part Number: 892179-5001S

Garrett PowerMax™ turbocharger upgrade for the Chevrolet Duramax 2.8L engine platform is engineered to increase engine performance while maintaining OEM installation specifications. This direct drop-in stage 1 upgrade provides up to 20% more flow than OEM and will support up to 160kW/ 215 BHP*. Variable turbine geometry is engineered to factory OEM specs and is controlled by the included module. Improvements in efficiency and flow can be attributed to the lightweight forged fully-machined compressor wheel with advanced aero design. This turbocharger is outline interchangeable with the OE hardware to ensure a perfect fit every time.

Contact your local authorized Garrett distributor for additional information and pricing.

**Please refer to the legal notice on page 114 before purchasing this product.*

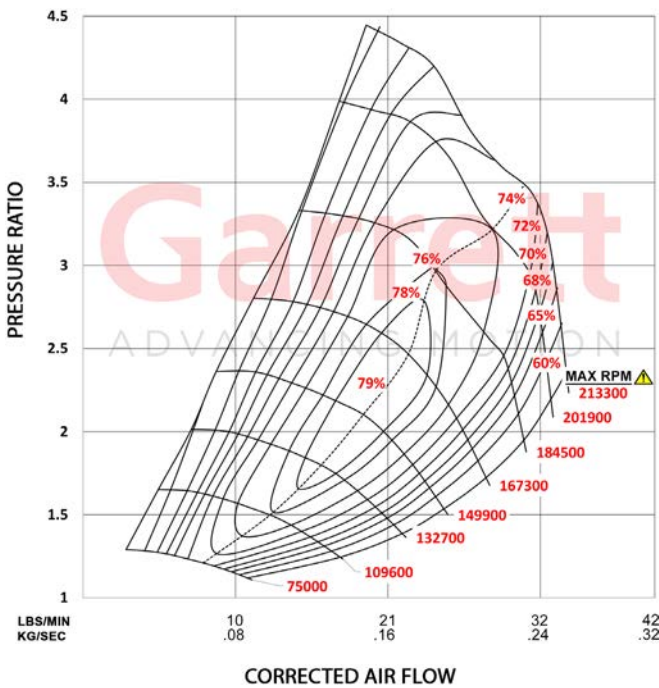

Part Number		892179-5001S
Turbo	Model	GTB1752V
	Comp Inducer	42mm
	Replaces OEM part numbers	814067-0005
		814067-0004
814067-0003		
Vehicle	Model	Colorado Colorado 7
	Year	2014 - 2019
Engine	Type	2.8L XLDE
	Fuel	Diesel
	Emission Regulation	Euro 3,4,5
	Cylinders	I4
	Horsepower	160kW / 215BHP*



WARNING: Maximum allowable turbocharger speed is 213.3krpm. The use of this product above max turbocharger speed is at the owner's risk, and can result in damage and premature failure. To protect the turbocharger from overspeed when operating, a speed sensor port is machined into the compressor housing for the fitment of speed sensor part numbers 781328-0001 (includes sensor and gauge), and 781328-0002 (includes speed sensor). Speed sensors sold separately.

* Estimated Horsepower. Performance results of this product are highly dependent upon your vehicle's modifications and tuning/calibration. The horsepower numbers represented above are calculated based strictly on choke flow of the compressor map (total turbo capability), which represents the potential flywheel horsepower.



POWERMAX™ DIRECT FIT PERFORMANCE TURBOCHARGER

Application: Stage 1 Turbo Upgrade For 2007 - 2018 Toyota Land Cruiser 4.5L 1VD-FTV
Part Number 881604-5001S

Supports up to 164kW*

This Garrett PowerMax™ direct fit turbocharger is designed for the 4.5L 1VD-FTV VS diesel engine platform found in the 2007-2018 Toyota Land Cruiser. The forged, fully machined compressor wheel designed for the G-Series product line increases flow by 20% over the OE wheel. Performance results of this product are highly dependent upon your vehicle's modifications and tuning. The power represented above was recorded on a chassis dyno with a modified ECU and OEM fuel delivery system enabling the engine to produce 164kW from the OE standard 151kW. All Garrett PowerMax™ direct fit turbochargers are outline interchangeable with the OE turbocharger ensuring a perfect fit every time.

**Please refer to the legal notice on page 114 before purchasing this product.*

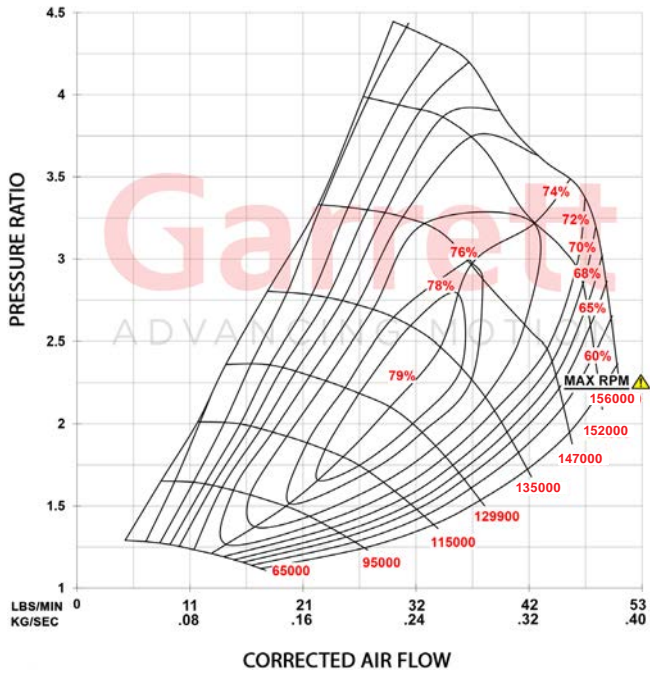

Part Number		881604-5001S
Turbo	Model	GTA2359V
	Interchangeable with OE PN	775095-0001 (5001S) 842127-0001 (5001S)
Vehicle	Make	Toyota
	Model	Land Cruiser
	Year	2007-2018
Engine	Type	4.5 L 1VD-FTV V8
	Fuel	Diesel
	Emissions	Euro IV
	Cylinders	8

Features:

- G-Series compressor wheel aerodynamics
- Wider compressor map for improved performance
- 20% more flow than the OE turbocharger
- VNT variable geometry technology



WARNING: Maximum allowable turbocharger speed is 156krpm. The use of this product above max turbocharger speed is at the owner's risk, and can result in damage and premature failure. To protect the turbocharger from overspeed when operating, a speed sensor port is machined into the compressor housing for the fitment of speed sensor part numbers 781328-0001 (includes sensor and gauge), and 781328-0002 (includes speed sensor). Speed sensors sold separately.

* Estimated Horsepower. Performance results of this product are highly dependent upon your vehicle's modifications and tuning/calibration. The horsepower numbers represented above are calculated based strictly on choke flow of the compressor map (total turbo capability), which represents the potential flywheel horsepower.



POWERMAX™ DIRECT FIT PERFORMANCE TURBOCHARGER

Application: Stage 1 Turbo Upgrade For 2011 - 2016 6.6L Chevrolet / GMC 2500HD, 3500HD
Part Number 886976-5004S

Supports up to 600WHP*

This Garrett PowerMax™ turbocharger upgrade for the Chevrolet and GMC 6.6L LML engine platform is engineered to increase engine performance while maintaining OEM installation specifications. This direct drop-in stage 1 upgrade provides 19% more flow than OEM and will support up to 600WHP*. Improvements in efficiency and flow can be attributed to the lightweight forged fully-machined compressor wheel. Boost response of this PowerMax turbocharger compared to OEM has not been tested. This turbocharger is outline interchangeable with the OE hardware to ensure a perfect fit every time.

**Please refer to the legal notice on page 114 before purchasing this product.*

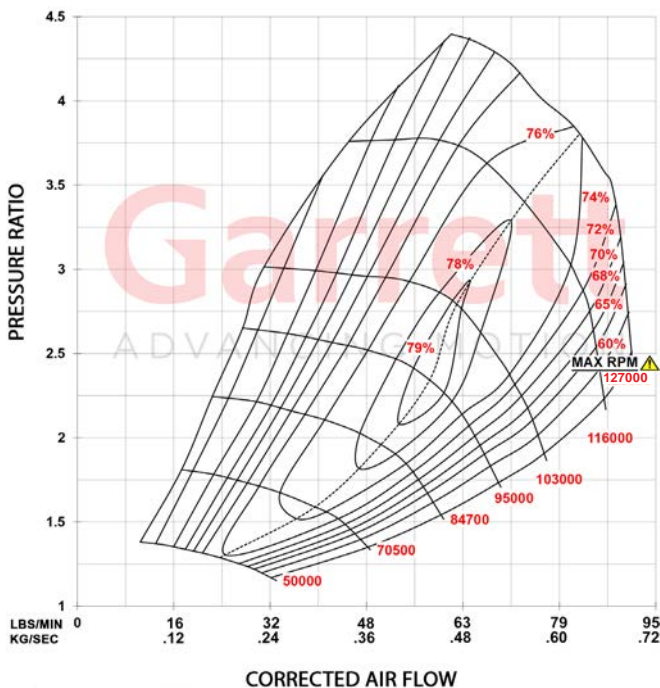

Part Number		886976-5004S
Turbo	Model	GT3788V
	Comp Ind	65mm
Vehicle	Make	Chevrolet GMC
	Model	2500HD 3500HD
	Year	2011 - 2016
Engine	Type	6.6L Duramax LML
	Fuel	Diesel
	Cylinders	8



WARNING: Maximum allowable turbocharger speed is 127krpm. The use of this product above max turbocharger speed is at the owner's risk, and can result in damage and premature failure. To protect the turbocharger from overspeed when operating, a speed sensor port can be machined into the compressor housing for the fitment of speed sensor part numbers 781328-0001 (includes sensor and gauge), and 781328-0002 (includes speed sensor). Speed sensors sold separately.

Available through the Master Distributors, Performance Distributors, and PowerMax™ Distributor networks.

* Estimated Horsepower. Performance results of this product are highly dependent upon your vehicle's modifications and tuning/calibration. The horsepower numbers represented above are calculated based strictly on choke flow of the compressor map (total turbo capability), which represents the potential flywheel horsepower.



7.3L Power Stroke



6.0L Power Stroke

POWERMAX™ DIRECT FIT PERFORMANCE TURBOCHARGER

Application: Stage 1 Turbo Upgrade For 7.3L | 6.0L Power Stroke Engines

*Please refer to the legal notice on page 114 before purchasing this product.

Ford Power Stroke Upgrade	Turbo PN	HP*	Compressor				Turbine			
			Inducer	Exducer	Trim	A/R	Inducer	Exducer	Trim	A/R
Power Stroke 7.3L 1999.5-2003	739619-5004S	590	66mm	88mm	56	1.00	76mm	68mm	79	1.00
Power Stroke 6.0L 2003 Stage 1	777469-5002S	560	64mm	88mm	52	0.58	73mm	66mm	84	0.90
Power Stroke 6.0L 2004-2007 Stage 1	772441-5002S	560	64mm	88mm	52	0.58	73mm	66mm	84	0.90

7.3L Power Stroke

Applications: 1999.5 - 2003 F250 | F350 | Excursion
Part Number 739619-5004s (590HP*)

The GTP38R turbocharger contains an exclusive ball bearing cartridge for unbeatable response, efficiency, and durability. Elimination of the thrust bearing eliminates failures at elevated boost levels. The 88mm GT compressor wheel provides 33% more flow than the stock 80mm wheel. A ported shroud housing improves compressor flow range for surge control. The kit includes a 1.00 A/R turbine housing for free flowing exhaust with reduced back pressure and up to 200° F reduction in exhaust gas temperature. Maximum recommended boost level is 40psi.

6.0L Power Stroke

Applications: 2003 Ford F-250 | F-350
Part Number 777469-5002S (560HP*)
Applications: 2004-2007 Ford F250 | F350 | Excursion
Part Number 772441-5002S (560HP*)

The GT3788VA Turbocharger features the Garrett patented Advanced Variable Nozzle. Turbine AVNT™ design for increased compressor flow and boost response. Utilizes nine movable vanes which significantly increase turbine efficiency and improve engine performance from idle launch through peak torque. Patented integral electro-hydraulic actuation and proportional solenoid for infinitely variable control. Larger compressor wheel over stock increases maximum power range while keeping turbo speeds down for the same power output.

 **WARNING:** Maximum allowable turbocharger speed is 127krpm (7.3L) and 134krpm (6.0L). The use of this product above max turbocharger speed is at the owner's risk, and can result in damage and premature failure. To protect the turbocharger from overspeed when operating, a speed sensor port can be machined into the compressor housing for the fitment of speed sensor part numbers 781328-0001 (includes sensor and gauge), and 781328-0002 (includes speed sensor). Speed sensors sold separately.

* Estimated Horsepower. Performance results of this product are highly dependent upon your vehicle's modifications and tuning/calibration. The horsepower numbers represented above are calculated based strictly on choke flow of the compressor map (total turbo capability), which represents the potential flywheel horsepower.

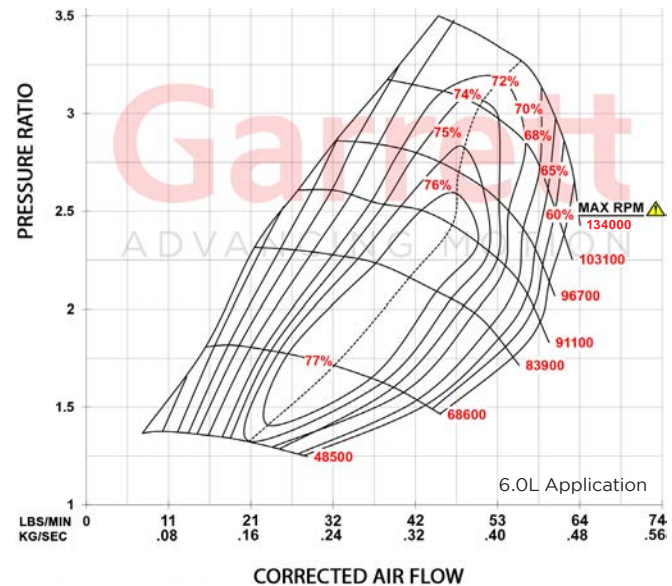
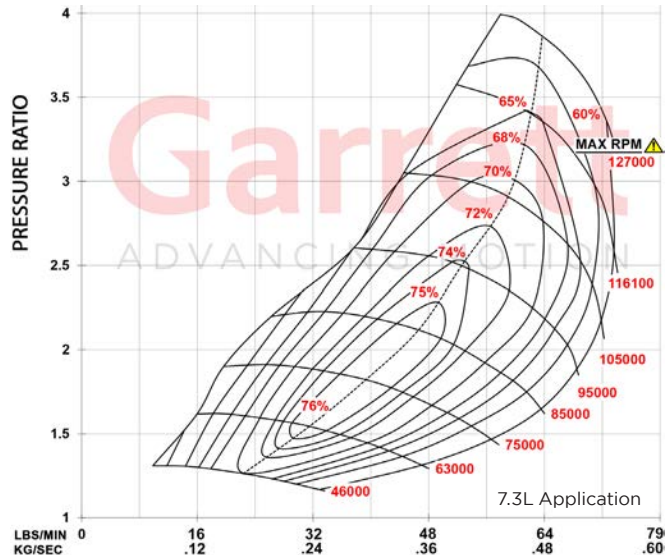



POWERMAX™ DIRECT FIT PERFORMANCE INTERCOOLER

Application: 2015+ Ford Mustang 2.3L EcoBoost
Supports Up To 600 Horsepower | C.A.R.B Certified ✓
Part Number: 857564-6001

The Garrett Direct Fit Performance Intercooler is C.A.R.B. certified (EO# D-794) and fits the 2015+ 2.3L EcoBoost Mustang in the stock location and can support up to 600 horsepower. The aluminum core features advanced offset fin design and vacuum brazed bar-and-plate construction resulting in superior thermal and fatigue performance. CFD optimized cast aluminum end tanks reduces recirculation and maximizes flow. The complete assembly results in up to a 30% reduction in pressure drop and up to a 40 °F reduction in charge air temperature.

This direct fit performance intercooler installs in 2.5 hours and reuses the stock bolts, hoses, and clamps. Removal of the OE grill shutters required. For more information including Installation instructions please visit our website: www.garrettmotion.com/racing-and-performance/performance-catalog/intercoolers/

Features:

- Supports up to 600 horsepower
- C.A.R.B Certified (EO# D-794)
- 60% larger core than stock
- Installs in stock location
- Up to a 40 °F reduction in temperatures

Part Number		857564-6001
Vehicle	Make	Ford
	Model	Mustang
	Year	2015+
Engine	Type	2.3L
	Fuel	Gas
Weight	16.5 LBS	
Size Specs	21" x 5.32" x 5.4"	





POWERMAX™ DIRECT FIT PERFORMANCE INTERCOOLER

Application: 2015+ Subaru WRX 2.0L

Supports Up To 530 Horsepower

Part Number: 891185-6001

The direct fit Subaru WRX performance charge air cooler boasts a 70% larger core that helps reduce intake manifold temperatures up to 30 °F (16.7 °C). Optimized end tanks improve air flow through the core. This performance intercooler showed an increase of up to 16 HP (12 kW) and 15 lb-ft (20 N-m) of torque compared to OE during back to back dyno comparisons in a wind tunnel which generates air velocity that matches vehicle speed. During testing the heat saturation point increased from 4 dyno pulls to 6 dyno pulls.

This direct fit performance intercooler installs in 2.5 hours and reuses the stock bolts, hoses, and clamps. Removal of the OE grill shutters required. For more information including Installation instructions please visit our website: www.garrettmotion.com/racing-and-performance/performance-catalog/intercoolers/

Features:

- Supports up to 530 HP (395 kW)
- 70% larger core than stock
- Installs in stock location
- Up to 16 HP (12kW) and 15 lb-ft (20 Nm) of torque
- Average 30° F (16.7° C) reduction in intake temp
- Cast aluminum end tanks
- Advanced offset fin design
- Bar-and-plate construction

Part Number		891185-6001
Vehicle	Make	Subaru
	Model	WRX
	Year	2015 +
Engine	Type	2.0L FA20F
	Fuel	Gas
Size Specs	13" x 4" x 10.2"	
	330mm x 102mm x 259mm	

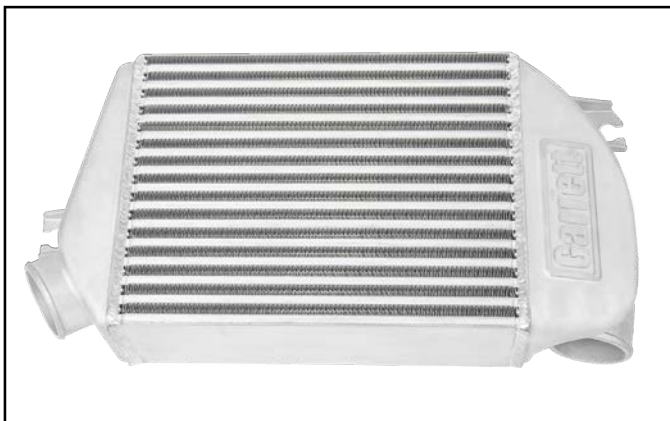



POWERMAX™ DIRECT FIT PERFORMANCE INTERCOOLER

Application: 2015+ BMW M3 | M4

Supports Up To 980 Horsepower

Part Number: 888883-6001 Raw Finish | 888883-6002 Black Finish

Garrett Powermax™ direct fit performance charge air cooler for the 2015+ BMW M3 and M4 boasts a 47% larger core with dual pass coolant flow to help reduce intake manifold temperatures by an average of 10 °F. CFD optimized end tanks improve airflow through the core. An average increase of 12.4 horsepower and 4.9 lb-ft of torque were measured during back to back dyno pulls. This direct-fit performance intercooler installs in 1.5 hours and reuses the stock bolts, hoses, and clamps.

Features:

- Supports up to 980 HP (730 kW)
- 47% larger core than stock
- Installs in stock location
- Up to 12.4 HP (9kW) and 4.9 lb-ft (6.7 Nm) of torque
- Cast aluminum end tanks
- Air-to-liquid design
- Bar-and-plate construction

Part Number	Raw Finish	888883-6001
	Black Finish	888883-6002
Vehicle	Make	BMW
	Model	M3 M4
	Year	2015+
Engine	Type	I6
	Fuel	Gas
Weight	14.1 lbs / 6.4 kg	
Size Specs	7.2" x 9.8" x 3.6"	
	183mm x 249mm x 92mm	





POWERMAX™ DIRECT FIT PERFORMANCE INTERCOOLER

Application: 2016+ Honda Civic 1.5T SI
Supports Up To 660 Horsepower
Part Number: 893516-6001

Garrett Powermax™ direct fit performance charge air cooler for the 2016+ Honda Civic 1.5T SI has a 90% larger core than stock and helps reduce intake manifold temperatures up to 60 °F (15.6 °C) at heat soak. CFD optimized end tanks improve air flow distribution through the core. This performance intercooler showed a max increase of up to 17 WHP (12.7 kW) and 14 lb-ft of torque (19 N-m) compared to OE during back to back dyno comparisons in a wind tunnel which generates air velocity that matches vehicle speed.

This direct fit performance intercooler installs in 3 hours and reuses the stock bolts, hoses, and clamps. Some modification to the shroud required. For more information including Installation instructions please visit www.garrettmotion.com/racing-and-performance/performance-catalog/intercoolers/

Features:

- Supports up to 660 HP (492 kW)
- 90% larger core than stock
- Installs in stock location
- Max increase of 17 HP (12.7 kW) and 14lb-ft (19 N-m)
- Up to 60 °F (15.6 °C) reduction in intake temp
- Cast aluminum end tanks
- Advanced offset fin design
- Bar-and-plate construction

Part Number		893516-6001
Vehicle	Make	Honda
	Model	Civic
	Year	2016+
Engine	Type	1.5L/SI
	Fuel	Gas
Weight	12.56 kg	
Size Specs	27.5" x 3.5" x 6.2"	
	698.5mm x 88.9mm x 157.5mm	





Garrett
ADVANCING MOTION

INTERCOOLER CORES

CHARGE AIR COOLERS

Utilizing advanced thermal technology, Garrett intercoolers offer superior fatigue protection for the high boost pressures and temperatures of today's extreme engines. With over 75 years of charge air cooler experience, Garrett remains ahead of the industry in intercooler design and function making it the number one choice for some of the premier names in the performance car industry - Roush, Saleen, Mercedes-Benz AMG, Ford SVT, GM, and McLaren have all turned to Garrett to cool their hottest models.

We now offer this expertise and quality to enthusiasts, in a full range of intercooler cores that are manufactured in-house by Garrett technicians. The bar and plate construction offers hi-performance, in a compact design using high strength vacuum brazed aluminum alloys with advanced fin designs to ensure greater heat transfer effectiveness and durability. From air-to-air cores sized for sport compact cars to air-to-liquid cores capable of supporting 1000+ hp, we can provide optimum performance for nearly any application.

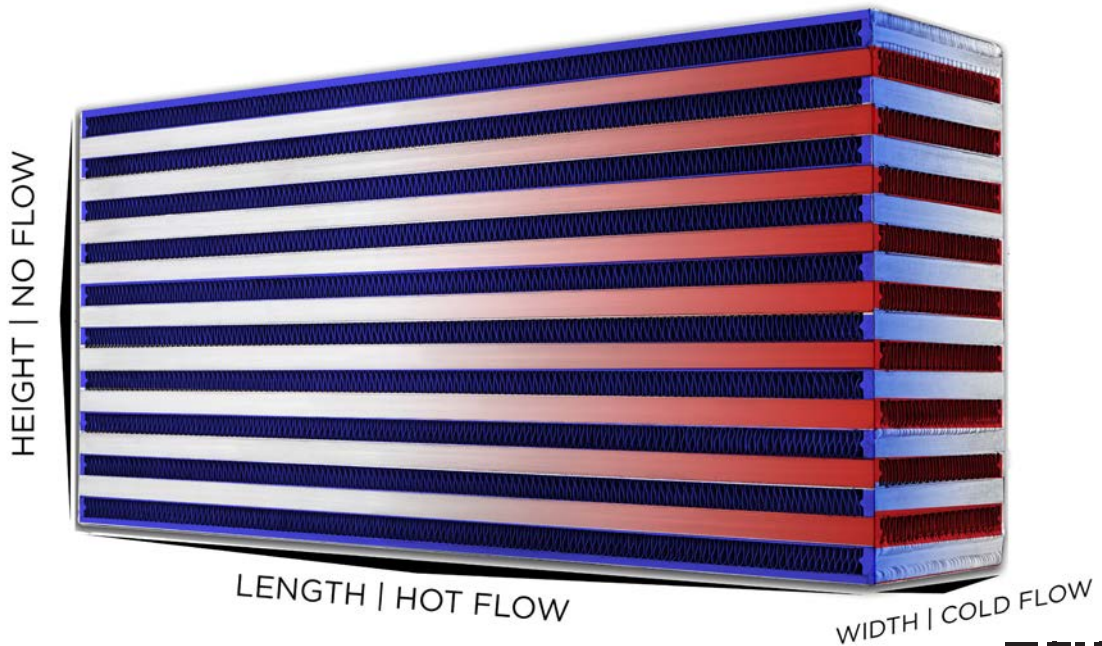



Part Number	Model	Supported Horsepower	Length Hot Flow		Height No Flow		Width Cold Flow	
			(in)	(mm)	(in)	(mm)	(in)	(mm)
* 848054-6012	Air / Air	300	10.2	260	8.1	205	4.7	120
703518-6015	Air / Air	310	18.0	457	6.4	163	3.0	76
703521-6003	Air / Air	375	10.0	254	12.3	312	4.5	114
703518-6016	Air / Air	410	18.0	457	8.0	203	3.0	76
703520-6025	Air / Air	425	18.0	457	8.0	203	3.5	89
* 848054-6013	Air / Air	450	13.5	343	8.6	219	5.5	140
703518-6018	Air / Air	475	24.0	610	6.4	163	3.0	76
703520-6009	Air / Air	500	24.0	610	6.4	163	3.5	89
703518-6017	Air / Air	510	18.0	457	10.5	267	3.0	76
703520-6002	Air / Air	550	14.0	356	12.1	307	3.5	89
848054-6004	Air / Air	600	21.0	533	5.4	137	5.3	135
848054-6024	Air / Air	600	13.0	330	10.2	259	4.0	102
487085-6002	Air / Air	600	20.1	511	11.2	284	3.0	76
703520-6010	Air / Air	600	24.0	610	8.0	203	3.5	89
893513-6001	Air / Air	660	27.5	699	6.2	157	3.5	89
* 848054-6037	Air / Air Vertical Flow	750	8.0	203	24.0	609	3.5	89
* 858893-6001	Air / Air	750	9.0	229	22.1	560	4.0	102
848054-6015	Air / Air	750	21.0	533	9.4	239	5.3	135
703518-6004	Air / Air	750	18.0	457	12.1	307	3.0	76
703522-6008	Air / Air	750	18.0	457	11.2	284	4.5	114
703522-6004	Air / Air	785	18.0	457	12.1	307	4.5	114
848054-6020	Air / Air	800	26.3	668	7.8	198	4.3	109
703520-6011	Air / Air	800	24.0	610	10.5	267	3.5	89
848054-6005	Air / Air	800	13.1	333	8.6	218	5.0	127
848054-6001	Air / Air	870	20.0	508	12.5	318	3.5	89
703518-6005	Air / Air	900	24.0	610	12.1	307	3.0	76
703520-6005	Air / Air	925	24.0	610	12.1	307	3.5	89
848054-6021	Air / Air	950	26.8	681	10.4	264	4.0	102
703522-6005	Air / Air	950	24.0	610	12.1	307	4.5	114
486827-6002	Air / Air	1000	23.7	602	12.0	305	3.8	97
* 848054-6039	Air / Air Vertical Flow	1100	12.0	305	22.4	568	4.5	114
848054-6003	Air / Air	1140	22.0	559	14.0	356	4.5	114
701596-6001	Air / Air	1260	27.8	706	12.7	323	5.1	130
* 858893-6003	Air / Air	1275	14.0	356	22.1	561	4.5	114

* New Cores

Part Number	Model	Supported Horsepower	Length Hot Flow		Height No Flow		Width Cold Flow	
			(in)	(mm)	(in)	(mm)	(in)	(mm)
717874-6009	Air / Liquid	500	3.8	97	3.8	97	9.8	249
717874-6008	Air / Liquid	750	3.8	97	3.8	97	11.7	297
873213-6002	Air / Liquid	980	7.2	183	3.6	91	9.8	249
734408-6005	Air / Liquid	1000	4.8	122	4.5	114	11.9	302

Garrett ancillary components are factory replacement parts for most G-Series and GTX Gen II turbochargers. From bolts, to clamps, actuator brackets, rod ends, o-rings and more. G-Series turbochargers have many new features on the compressor and CHRA sides of the turbo. The new speed sensor plug, bolt, and o-ring, pressure port plug, and oil and water fittings to name a few. These small ancillary components are now available for purchase.

Part Number	Description	Model
400809-0203	Pressure Plug Comp Hsg	G-Series GTX42 45 47 50 55 Gen II
403069-0242	O-Ring Speed Sensor	G-Series GTX47 50 55 Gen II
871104-0001	Plug Speed Sensor	
400674-0516	Bolt Speed Sensor	
400975-0203	Bolt Compressor Hsg	G25 G30 G35-900
400975-0303	Bolt Compressor Hsg	G35-1050 GTX28 Gen II
871795-0001	Clamp Compressor Hsg	G25 G30 G35-900
871795-0003	Clamp Compressor Hsg	G35-1050
403069-0077	O-Ring Compressor Hsg	GTX30 35 Gen II
403069-0157	O-Ring Compressor Hsg	G25 G30-660
403069-0162	O-Ring Compressor Hsg	G30-770 G30-900 G35
403069-0164	O-Ring Backplate	GTX28 30 35 Gen II
767567-0002	Fitting Oil Inlet	G25 30 35 GTX28 30 35 Gen II
434705-00041	Plug Water	
872902-0001	Fitting Water	
444657-0006	Washer Copper	
400702-1025	Circlip Rod End	
413885-0032	Rod End	
400146-0207	Nut Actuator Bracket / Rod End	
876079-0001	Bracket Actuator Standard Rotation	
876079-0002	Bracket Actuator Reverse Rotation	
876079-0003	Bracket Actuator Twin Scroll	
826466-0001	V-Band Turbine Inlet	G25 30 35 GTX30 35 Gen II GTX28 (Turbine Outlet)
446397-0364	V-Band Turbine Outlet	G25 30 35 GTX30 35 Gen II
446397-0382	V-Band Center Hsg - Turbine Hsg	G25 30 35
400515-0212	Locknut V-Band	G-Series GTX Gen II



BOLTED INLET TURBINE HOUSINGS: T25 | T3 | T4 | T6 | GBC14

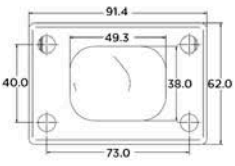

T25

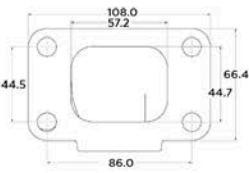

T3

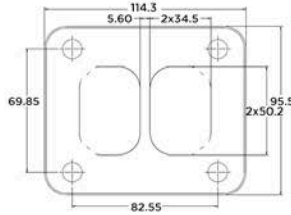

T4

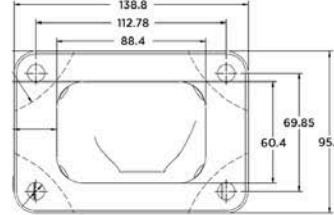

T6

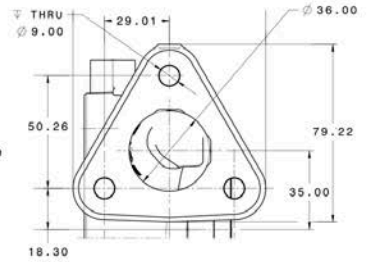

GBC14

V-BAND INLET TURBINE HOUSINGS:

Diagram	V-Band Turbine Inlet Flange Reference		
1	GT28	GTX28	GTX28 Gen II
2	G25	G30	G35
2	GT30	GTX30	GTX30 Gen II
2	GT35	GTX35	GTX35 Gen II
3	G42	G45	G40
4	G57 G55	GTX55	GTX55 Gen II

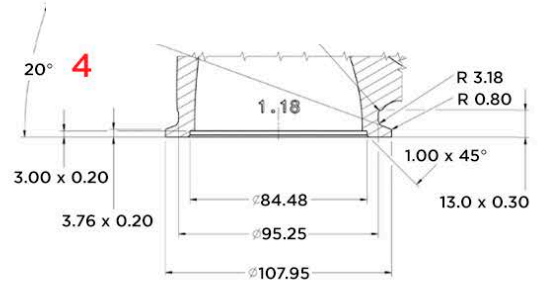
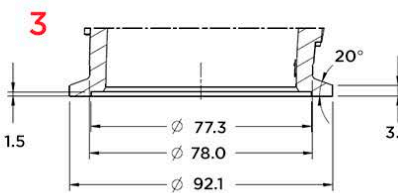

TURBINE HOUSING OUTLET (DOWN PIPE) FLANGE

Garrett Series	Turbine Housing Inlet Type						
	All	V-Band	T25	T3	T3 WG	T4	T6
G25 G30 G35	5						
G40 G42 G45		6				19	
G47 G50	8						
G55		9					8
G57	9						
GT28 GTX28 GT25		7	15				
GT28 RB Style			16				
GBC14			15				
GBC17 20 22	18						
GBC35 GBC37	5						
GT30 GTX30		5		17	14		
GT35 GTX35		5		17	14	20	
GTX40	11						
GTX42 GTX45	12						
GTX47 GTX50	8						8
GTX55		9					8
GTX36 GTW38	13						
GT2052	10						
GT2252	21						

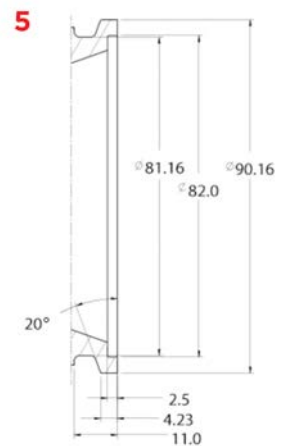

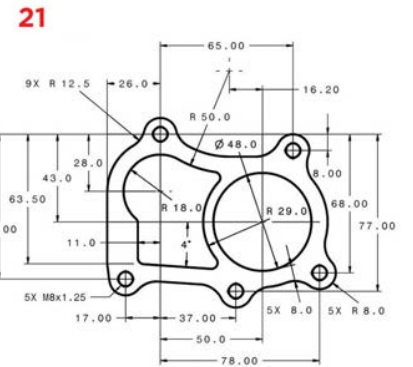
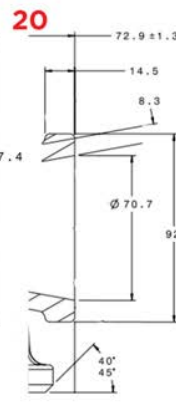
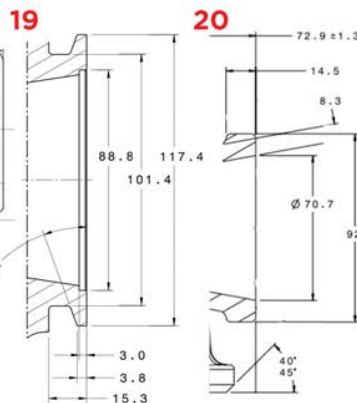
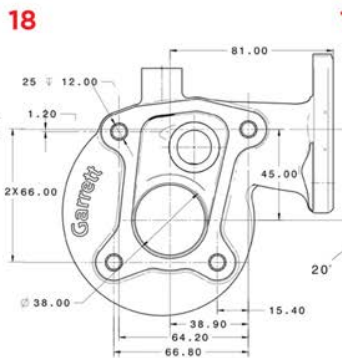
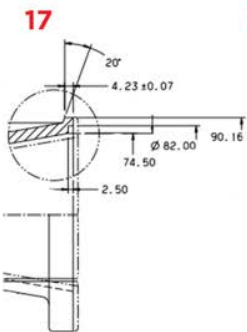
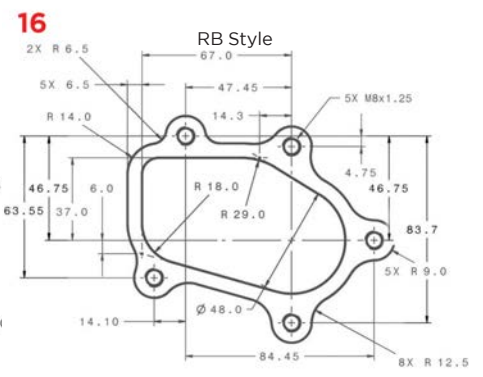
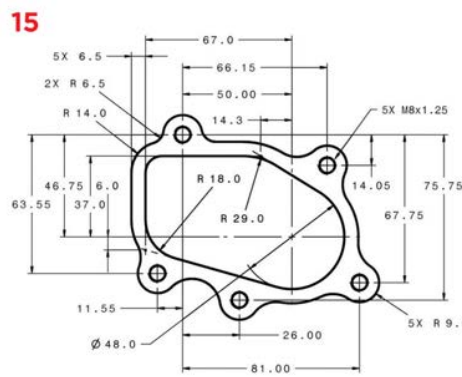
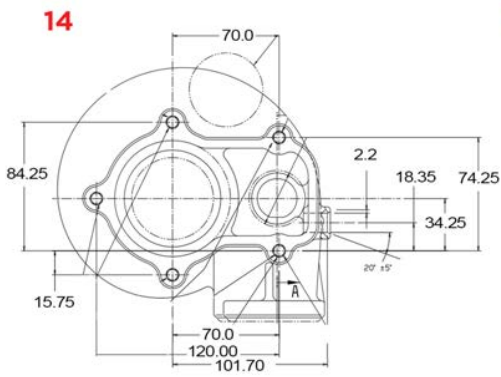
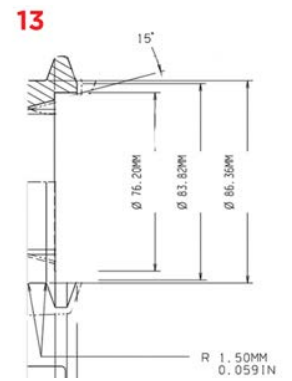
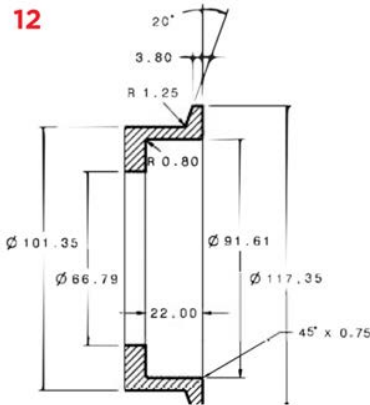
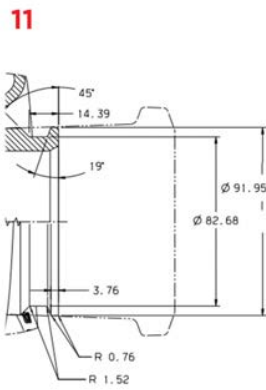
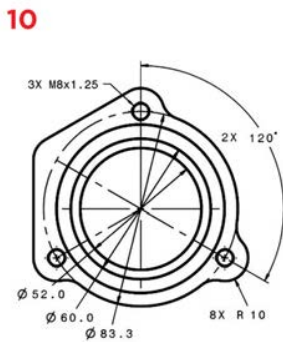
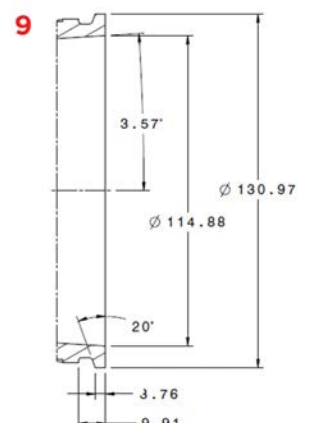
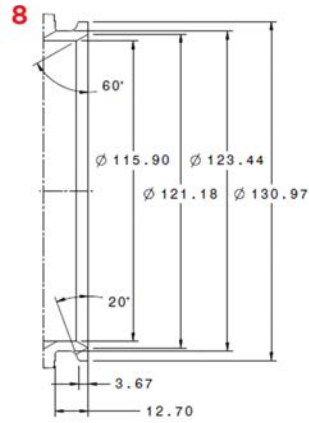
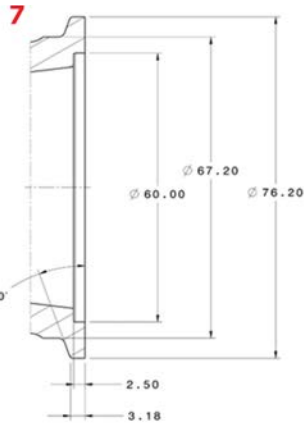
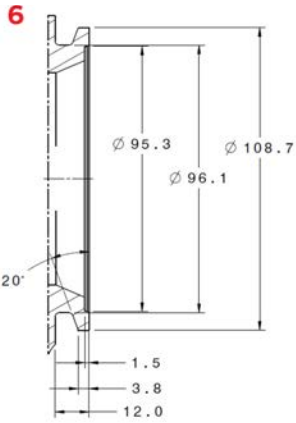

POSSIBLE CAUSES	SYMPTOMS								SOLUTION			
	Engine lacks power	Black smoke	Excessive oil consumption	Blue smoke	Noise	Excessive oil - compressor end	Excessive oil - turbine end	Drag or bind in rotating assembly		Excessive rotating assembly play	Damaged compressor wheel	Damaged turbine wheel
Dirty air cleaner element	●	●										Clean or replace filter element
Plugged crankcase breathers			●									Clear obstruction per manufacturer's manual
Air cleaner element missing, leaking, or loose connections to turbo								●				Replace, repair or reconnect air cleaner element per manufacturer's manual
Collapsed or restricted air pipe before turbocharger	●	●				●	●					Inspect pipe for damage or obstruction, replace or repair
Restricted or damaged crossover pipe - turbo to inlet manifold	●	●				●	●					Inspect pipe for damage or obstruction, replace or repair
Foreign object between cleaner and turbocharger	●	●				●	●		●	●		Inspect air intake piping, remove foreign object
Foreign object in exhaust system (check engine)	●	●				●	●		●	●	●	Inspect exhaust piping only when engine is not running and cold, remove foreign object
Turbocharger flanges, clamp or bolts loose	●	●	●	●	●	●	●	●	●	●	●	Inspect all connecting hardware for damage, ensure tight fits per installation instructions
Inlet manifold cracked, gaskets, loose or missing, connections loose	●	●				●	●					Remove and inspect inlet manifold for damage to castings and gaskets, replace if needed
Exhaust manifold cracked, burned, gasket loose, blown or missing	●	●				●						Remove exhaust manifold only when engine is cold and not running and inspect for damage to castings and gaskets, replace if needed
Restricted exhaust system						●						Inspect exhaust system only when engine is cold, not running, remove obstruction
Oil lag at start-up									●	●		Inspect lubrication system lines, filters and oil for obstruction, remove obstruction
Insufficient lubrication									●	●		Inspect lubrication system lines, filters and oil for obstruction, remove obstruction
Lubricating oil contaminated with dirt or other material									●	●		Replace all filters and lubricating oil with new per manufacturer's manual
Improper lubricating oil type used									●	●		Replace lubricating oil with correct grade
Restricted oil feed line							●	●	●	●		Remove and inspect oil line, remove obstruction
Restricted oil drain line				●								Remove and inspect oil line, remove obstruction
Turbine housing damaged or restricted	●	●				●					●	Remove turbine housing, inspect for cracks or wear, replace if needed
Turbocharger seal leakage				●	●	●	●					Inspect for proper oil feed / drain line installation. Contact Garrett distributor for rebuild
Worn journal bearings	●	●	●			●	●	●	●	●	●	Contact a Garrett performance distributor or Garrett master distributor
Excessive dirt build-up behind turbine wheel	●	●				●	●		●	●	●	Inspect air cleaner element and intake piping for damage or leaks, replace if needed. Clean compressor wheel and housing
Excessive carbon build-up behind compressor housing	●	●				●	●				●	Inspect crankcase ventilation
Too fast acceleration at initial start									●	●		Decrease acceleration at initial start
Too little warm-up time									●	●		Extend warm-up period
Fuel pump malfunction	●	●										Refer to engine manufacturer's manual and replace if needed
Worn or damaged injectors	●	●										Inspect injectors for damage and replace if needed
Valve timing	●	●										Refer to engine manufacturer's manual and replace if needed
Burned valves	●	●										Refer to engine manufacturer's manual and replace if needed
Worn piston rings	●	●										Refer to engine manufacturer's manual and replace if needed
Burned pistons									●	●		Refer to engine manufacturer's manual and replace if needed
Leaking oil feed line					●		●					Remove and inspect oil line, remove obstruction
Excessive engine pre-oil					●	●	●					Refer to engine manufacturer's manual and replace if needed
Excessive engine idle					●	●	●				●	Refer to engine manufacturer's manual and replace if needed
Coked or sludged center housing											●	Contact a Garrett performance distributor or Garrett master distributor
Oil pump malfunction					●	●	●	●	●	●	●	Refer to engine manufacturer's manual and replace if needed
Oil filter plugged	●	●	●	●	●							Refer to engine manufacturer's manual and replace if needed
Oil bath cleaner: air inlet screen restricted / dirty air cleaner	●	●	●	●	●							Replace air inlet screen
Oil bath air cleaner: oil pull-over / oil viscosity too low or high	●	●	●	●	●							Replace lubricating oil with correct grade
Boost control malfunction: wastegate	●	●	●	●	●	●	●		●	●	●	Inspect for damage, leaks or obstructions; replace or repair if needed
Boost control malfunction: vnt	●	●	●	●	●	●	●		●	●	●	Contact a Garrett performance distributor or Garrett master distributor
Boost control malfunction: engine management system	●	●	●	●	●	●	●		●	●	●	Refer to manufacturer's manual and adjust as needed

● Probable cause
□ Not a probable cause

Nearly all turbocharger-related problems are the result of a handful of causes. Knowing how to recognize the symptoms of these issues early and link them with causes will help you save downtime and money. The chart above outlines the probable causes and noticeable conditions of the most common turbocharger maladies as well as what you can do to solve them. If a problem falls outside of your mechanical comfort level, contact a Performance Distributor or a Master Distributor for assistance. www.GarrettMotion.com/Racing-and-Performance/Distributor-Locator/

Terms and Conditions

Garrett, the Garrett Advancing Motion logo, and all product names appearing on our websites are among the trademarks and/or service marks owned by Garrett Transportation I Inc., a subsidiary of Garrett Motion Inc. (collectively referred to herein as “Garrett”). No trademark or service mark or other license is granted in connection with the materials contained on any of Garrett’s websites.

Nothing contained herein shall be construed as conferring by implication, estoppel or otherwise a license to any patent, trademark or other intellectual property of Garrett or any third party. Garrett makes no representations or warranties that use of the information contained on this website will not infringe any patent, trademark or other intellectual property right of Garrett or any third party. Should you view Garrett’s website and respond with information (excluding personal information, which is addressed under the Internet Privacy Policy) including questions, comments or suggestions, such information shall be deemed to be non-confidential and Garrett shall have no obligation with respect to such information and shall be free to reproduce, use, disclose and distribute the information without limitation. Garrett shall be free to use any ideas, concepts, know-how or techniques contained in such information for any purpose including but not limited to developing, manufacturing and marketing products incorporating such information.

Under no circumstances will Garrett be liable to any person or entity for direct, indirect, special, incidental, consequential or other damages based on use of this website or any other website to which this website is linked, including, without limitation, lost profits, business interruption, or loss of programs or information, even if Garrett has been specifically advised of the possibility of such damages.

Consumers are required to work through an authorized Garrett distributor to process warranty claims. When Garrett requires the examination of a failed part, Garrett will promptly notify Customer and will await receipt of the failed part before processing the claim. If Garrett ultimately determines that the failed part is covered under the Limited Warranty, Garrett will reimburse Customer for the actual cost of ground shipment for any part found to be defective.

No representative or distributor of Garrett has authority to alter this warranty. This warranty may only be modified by an agreement signed by an authorized officer of a Garrett legal entity.

We recommend that Garrett products be installed by qualified automotive technicians. If you have doubts as to your ability to install our product, consult with a local automotive repair company. Carefully read all attached instructions prior to starting installation. If you have questions about the enclosed parts or instructions, call the distributor that you purchased the kit from for clarification. Prior to product installation, ensure that the vehicle is parked on a level surface and the engine is cool. Engine fluids and components can be extremely hot following normal vehicle operation. Avoid direct contact of engine fluids or components.



BOOST ADVISER

TURBO MATCHING MADE EASY

MOBILE AND DESKTOP DEVICES

1. ENTER YOUR PARAMETERS
2. BROWSE TURBO MATCHES
3. LOCATE A DISTRIBUTOR

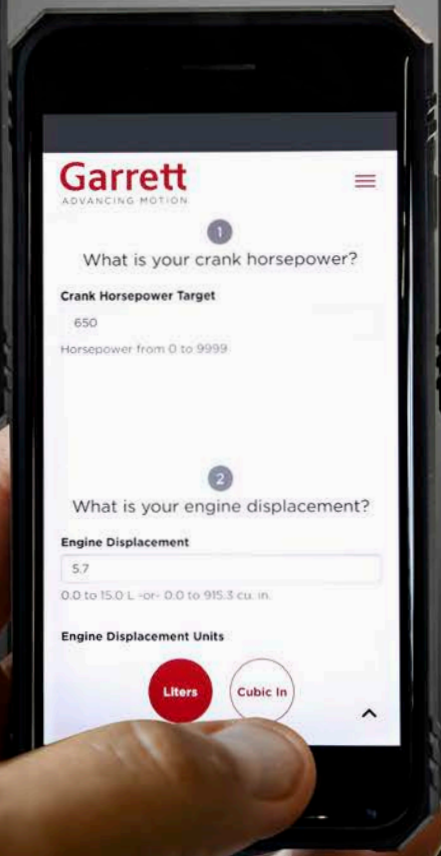
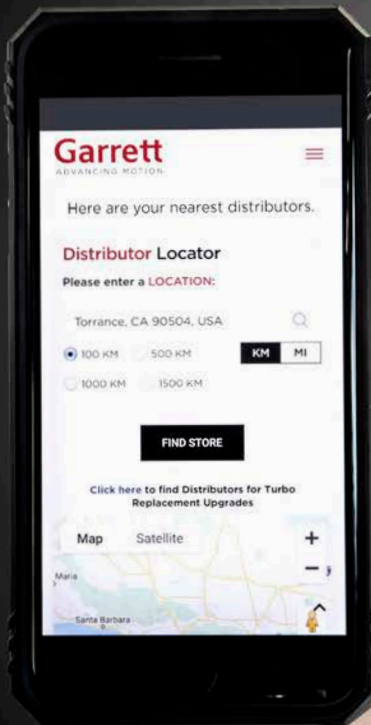

Garrett
ADVANCING MOTION